



Addendum #4
December 8, 2023

WAR TR55 2.11 (PID 114603)

Questions and answers received from contractors:

Question: The Clearing and Grubbing, As Per Plan note on plan sheet 4 says there are no trees specifically marked for removal but there are 15 trees marked for removal on plan sheets 16 through 18. Will the clearing note be revised?

Answer: There are trees marked on the plans that will need to be removed for the trail, but some trees may be able to be saved once the trail is laid out.

Question: The Tree Replacement note on plan sheet 4 says the contractor shall supply and plant one 3" caliper tree for every tree removed during construction and proposal lists ref no. 10 Tree Replacement as 1 LS. Will the Tree Replacement item be revised to 15 each to match the trees marked to be removed?

Answer: See next question/question.

Question: The Tree Replacement note on plan sheet 4 says the contractor shall supply and plant one 3" caliper tree for every tree removed during construction. There are many small trees not marked for removal on the plans that will have to be removed for construction of the proposed retaining wall and headwalls (see attached photos for examples). What is the minimum size for trees that have to be replaced and how will these measurements be made? Will the Tree Replacement item unit be changed to "each"?

Answer: Bid Proposal Line 10 has been revised from 1 LS to 21 EACH.

Question: The typical sections on plan sheet 3 show Combination Curb and Gutter Type 2 but the general summary and proposal list Curb Type 6. What type of curb is required?

Answer: Bid Proposal Line 35 has been revised to "CURB, TYPE 2"

Question: Plan sheets 14, 17, 39 and 40 show a proposed manhole near headwall #2 about station 15+34 but the proposal has ref no. 27 "Manhole, No 3, Adjust to Grade". Will ref no. 27 be changed to "Manhole, No 3"?

Answer: Bid Proposal Line 27 has be revised to "MANHOLE, NO 3".

Ref No.	Item No.	Item Ext	Item Description	Quantity	Unit
10	661	99940	PLANTING, MISC.: TREE REPLACEMENT	21	EACH
27	611	99574	MANHOLE, NO 3	1	EACH
35	609	26000	CURB, TYPE 2	26	FT

Attached is a revised Bid Proposal (3 sheets) for the above referenced Project. A hard copy filled out by the contractor shall be submitted with the bid.

Also, available for your use upon request email from Dan Corey is a Bid Proposal excel spreadsheet (dan.corey@co.warren.oh.us).

WAR-TR55-2.11 - PID 114603

Ref No.	Item No.	Item Ext	Item Description	Quantity	Unit	Unit Price	Total Cost
ROADWAY							
1	201	11000	CLEARING AND GRUBBING, AS PER PLAN	1	LUMP		
2	202	20010	HEADWALL REMOVED	5	EACH		
3	202	30000	WALK REMOVED	9	SF		
4	202	32000	CURB REMOVED	45	FT		
5	203	10000	EXCAVATION	1246	CY		
6	203	20000	EMBANKMENT	646	CY		
7	209	60501	LINEAR GRADING, AS PER PLAN	1	MILE		
8	607	98000	FENCE, MISC.: DECORATIVE RAILING	1502	FT		
9	611	99654	MANHOLE ADJUSTED TO GRADE	3	EACH		
10	661	99940	PLANTING, MISC.: TREE REPLACEMENT	21	EACH		
11	878	25000	INSPECION AND COMPACTION TESTING OF UNBOUND MATERIALS	1	LS		
ROADWAY SUBTOTAL					\$		-
EROSION CONTROL							
12	616	10000	WATER	1	MGAL		
13	659	00300	TOPSOIL	143	CY		
14	659	10000	SEEDING AND MULCHING	1284	SY		
15	659	14000	REPAIR SEEDING AND MULCHING	64	SY		
16	659	20000	COMMERCIAL FERTILIZER	0.17	TON		
17	659	31000	LIME	0.27	ACRE		
18	659	35000	WATER	6.9	MGAL		
19	832	30000	EROSION CONTROL	20000	EACH		
EROSION CONTROL SUBTOTAL					\$		-
DRAINAGE							
20	605	06020	4" BASE PIPE UNDERDRAINS WITH GEOTEXTILE FABRIC	300	FT		
21	611	00410	4" CONDUIT, TYPE F FOR UNDERDRAIN OUTLET	20	FT		
22	611	00901	6" CONDUIT, TYPE B, AS PER PLAN, FOR DRAINAGE CONNECTION	100	FT		
23	611	04200	12" CONDUIT, TYPE A, 706.04	16	FT		

WAR-TR55-2.11 - PID 114603

24	611	05700	15" CONDUIT, TYPE A, 706.04	9	FT		
25	611	52400	22" X 34" CONDUIT, TYPE A 706.04	10	FT		
26	611	52700	29" X 45" CONDUIT, TYPE A 706.04	16	FT		
27	611	99574	MANHOLE, NO 3	1	EACH		
DRAINAGE SUBTOTAL					\$		-
PAVEMENT							
28	204	10000	SUBGRADE COMPACTION	3064	SY		
29	301	56000	ASPHALT CONCRETE BASE, PG64-22, (449)	330	CY		
30	304	20000	AGGREGATE BASE	520	CY		
31	407	10000	TACK COAT	180	GAL		
32	441	70000	ASPHALT CONCRETE SURFACE COURSE, TYPE 1, (449), PG64-22	130	CY		
33	608	12000	5" CONCRETE WALK	476	SF		
34	608	52000	CURB RAMP, AS PER PLAN	108	SF		
35	609	26000	CURB, TYPE 2	26	FT		
PAVEMENT SUBTOTAL					\$		-
TRAFFIC CONTROL							
36	646	03100	GROUND MOUNTED SUPPORT, NO. 3 POST	66.5	FT		
37	646	84900	REMOVAL OF GROUND MOUNTED SIGN AND DISPOSAL	1	EACH		
38	646	85100	REMOVAL OF GOURND MOUNTED SIGN AND REERECTION	5	EACH		
39	646	85200	REMOVAL OF GOURND MOUNTED SIGN AND DELIVERY	1	EACH		
40	646	86002	REMOVAL OF GROUND MOUNTED POST SUPPORT AND DISPOSAL	1	EACH		
41	646	86002	LANE LINE, 6" TYPE 1	0.55	MILE		
TRAFFIC CONTROL SUBTOTAL					\$		-
RETAINING WALLS							
42	503	21100	UNCLASSIFIED EXCAVATION	345	CY		
43	451	13021	8" REINFORCED CONCRETE PAVEMENT, CLASS QC 1P WITH QC/QA, AS PER PLAN	18	SY		
44	509	10000	EPOXY COATED REINFORCING STEEL	6529	LB		
45	511	46213	CLASS QC1 CONCRETE, RETAINING/WINGWALL INCLUDING FOOTING, AS PER PLAN	74	CY		

WAR-TR55-2.11 - PID 114603

46	511	46612	CLASS QC1 CONCRETE WITH QC/QA, HEADWALL	19	CY		
47	518	21200	POURUS BACKFILL WITH GEOTEXTILE FABRIC	42	CY		
TRAFFIC SIGNAL SUBTOTAL					\$	-	
MAINTENANCE OF TRAFFIC							
48	614	12440	WORK ZONE SIGN SUPPORT	1	EACH		
49	614	22210	WORK ZONE EDGE LINE, CLASS I, 6", 740.06, TYPE I	1	MILE		
50	614	24404	WORK ZONE DOTTED LINE, CLASS I, 8", 740.06, TYPE I	200	FT		
51	614	300000	WORK ZONE ARROW, CLASS I	5	EACH		
52	614	31000	WORK ZONE WORD ON PAVEMENT, 72", CLASS I	4	EACH		
MAINTENANCE OF TRAFFIC SUBTOTAL					\$	-	
INCIDENTALS							
53	614	11000	MAINTAINING TRAFFIC	1	LUMP		
54	623	10000	CONSTRUCTION LAYOUT STAKES AND SURVEYING	1	LUMP		
55	624	10000	MOBILIZATION	1	LUMP		
MISCELLANEOUS SUBTOTAL					\$	-	
TOTAL AMOUNT				-			



Addendum #3
November 22, 2023

WAR TR55 2.11 (PID 114603)

Attached is a revised Bid Proposal (3 sheets) for the above referenced Project. A hard copy filled out by the contractor shall be submitted with the bid.

Quantity changes highlighted below:

Ref No.	Item No.	Item Ext	Item Description	Quantity	Unit
45	511	46213	CLASS QC1 CONCRETE, RETAINING/WINGWALL INCLUDING FOOTING, AS PER PLAN	74	CY
46	511	46612	CLASS QC1 CONCRETE WITH QC/QA, HEADWALL	19	CY

Also, available for your use upon request email from Dan Corey is a Bid Proposal excel spreadsheet (dan.corey@co.warren.oh.us).

WAR-TR55-2.11 - PID 114603

Ref No.	Item No.	Item Ext	Item Description	Quantity	Unit	Unit Price	Total Cost
ROADWAY							
1	201	11000	CLEARING AND GRUBBING, AS PER PLAN	1	LUMP		
2	202	20010	HEADWALL REMOVED	5	EACH		
3	202	30000	WALK REMOVED	9	SF		
4	202	32000	CURB REMOVED	45	FT		
5	203	10000	EXCAVATION	1246	CY		
6	203	20000	EMBANKMENT	646	CY		
7	209	60501	LINEAR GRADING, AS PER PLAN	1	MILE		
8	607	98000	FENCE, MISC.: DECORATIVE RAILING	1502	FT		
9	611	99654	MANHOLE ADJUSTED TO GRADE	3	EACH		
10	661	99940	PLANTING, MISC.: TREE REPLACEMENT	1	LS		
11	878	25000	INSPECION AND COMPACTION TESTING OF UNBOUND MATERIALS	1	LS		
ROADWAY SUBTOTAL					\$		-
EROSION CONTROL							
12	616	10000	WATER	1	MGAL		
13	659	00300	TOPSOIL	143	CY		
14	659	10000	SEEDING AND MULCHING	1284	SY		
15	659	14000	REPAIR SEEDING AND MULCHING	64	SY		
16	659	20000	COMMERCIAL FERTILIZER	0.17	TON		
17	659	31000	LIME	0.27	ACRE		
18	659	35000	WATER	6.9	MGAL		
19	832	30000	EROSION CONTROL	20000	EACH		
EROSION CONTROL SUBTOTAL					\$		-
DRAINAGE							
20	605	06020	4" BASE PIPE UNDERDRAINS WITH GEOTEXTILE FABRIC	300	FT		
21	611	00410	4" CONDUIT, TYPE F FOR UNDERDRAIN OUTLET	20	FT		
22	611	00901	6" CONDUIT, TYPE B, AS PER PLAN, FOR DRAINAGE CONNECTION	100	FT		
23	611	04200	12" CONDUIT, TYPE A, 706.04	16	FT		

WAR-TR55-2.11 - PID 114603

24	611	05700	15" CONDUIT, TYPE A, 706.04	9	FT		
25	611	52400	22" X 34" CONDUIT, TYPE A 706.04	10	FT		
26	611	52700	29" X 45" CONDUIT, TYPE A 706.04	16	FT		
27	611	99574	MANHOLE, NO 3, AJUST TO GRADE	1	EACH		
DRAINAGE SUBTOTAL					\$		-
PAVEMENT							
28	204	10000	SUBGRADE COMPACTION	3064	SY		
29	301	56000	ASPHALT CONCRETE BASE, PG64-22, (449)	330	CY		
30	304	20000	AGGREGATE BASE	520	CY		
31	407	10000	TACK COAT	180	GAL		
32	441	70000	ASPHALT CONCRETE SURFACE COURSE, TYPE 1, (449), PG64-22	130	CY		
33	608	12000	5" CONCRETE WALK	476	SF		
34	608	52000	CURB RAMP, AS PER PLAN	108	SF		
35	609	26000	CURB, TYPE 6	26	FT		
PAVEMENT SUBTOTAL					\$		-
TRAFFIC CONTROL							
36	646	03100	GROUND MOUNTED SUPPORT, NO. 3 POST	66.5	FT		
37	646	84900	REMOVAL OF GROUND MOUNTED SIGN AND DISPOSAL	1	EACH		
38	646	85100	REMOVAL OF GOURND MOUNTED SIGN AND REERECTION	5	EACH		
39	646	85200	REMOVAL OF GOURND MOUNTED SIGN AND DELIVERY	1	EACH		
40	646	86002	REMOVAL OF GROUND MOUNTED POST SUPPORT AND DISPOSAL	1	EACH		
41	646	86002	LANE LINE, 6" TYPE 1	0.55	MILE		
TRAFFIC CONTROL SUBTOTAL					\$		-
RETAINING WALLS							
42	503	21100	UNCLASSIFIED EXCAVATION	345	CY		
43	451	13021	8" REINFORCED CONCRETE PAVEMENT, CLASS QC 1P WITH QC/QA, AS PER PLAN	18	SY		
44	509	10000	EPOXY COATED REINFORCING STEEL	6529	LB		
45	511	46213	CLASS QC1 CONCRETE, RETAINING/WINGWALL INCLUDING FOOTING, AS PER PLAN	74	CY		

WAR-TR55-2.11 - PID 114603

46	511	46612	CLASS QC1 CONCRETE WITH QC/QA, HEADWALL	19	CY		
47	518	21200	POURUS BACKFILL WITH GEOTEXTILE FABRIC	42	CY		
TRAFFIC SIGNAL SUBTOTAL					\$	-	
MAINTENANCE OF TRAFFIC							
48	614	12440	WORK ZONE SIGN SUPPORT	1	EACH		
49	614	22210	WORK ZONE EDGE LINE, CLASS I, 6", 740.06, TYPE I	1	MILE		
50	614	24404	WORK ZONE DOTTED LINE, CLASS I, 8", 740.06, TYPE I	200	FT		
51	614	300000	WORK ZONE ARROW, CLASS I	5	EACH		
52	614	31000	WORK ZONE WORD ON PAVEMENT, 72", CLASS I	4	EACH		
MAINTENANCE OF TRAFFIC SUBTOTAL					\$	-	
INCIDENTALS							
53	614	11000	MAINTAINING TRAFFIC	1	LUMP		
54	623	10000	CONSTRUCTION LAYOUT STAKES AND SURVEYING	1	LUMP		
55	624	10000	MOBILIZATION	1	LUMP		
MISCELLANEOUS SUBTOTAL					\$	-	
TOTAL AMOUNT				-			



Addendum #2
November 22, 2023

WAR TR55 2.11 (PID 114603)

Attached is a revised Bid Proposal (3 sheets) for the above referenced Project. A hard copy filled out by the contractor shall be submitted with the bid.

Also, available for your use upon request email from Dan Corey is a Bid Proposal excel spreadsheet (dan.corey@co.warren.oh.us).

WAR-TR55-2.11 - PID 114603

Ref No.	Item No.	Item Ext	Item Description	Quantity	Unit	Unit Price	Total Cost
ROADWAY							
1	201	11000	CLEARING AND GRUBBING, AS PER PLAN	1	LUMP		
2	202	20010	HEADWALL REMOVED	5	EACH		
3	202	30000	WALK REMOVED	9	SF		
4	202	32000	CURB REMOVED	45	FT		
5	203	10000	EXCAVATION	1246	CY		
6	203	20000	EMBANKMENT	646	CY		
7	209	60501	LINEAR GRADING, AS PER PLAN	1	MILE		
8	607	98000	FENCE, MISC.: DECORATIVE RAILING	1502	FT		
9	611	99654	MANHOLE ADJUSTED TO GRADE	3	EACH		
10	661	99940	PLANTING, MISC.: TREE REPLACEMENT	1	LS		
11	878	25000	INSPECION AND COMPACTION TESTING OF UNBOUND MATERIALS	1	LS		
ROADWAY SUBTOTAL					\$		-
EROSION CONTROL							
12	616	10000	WATER	1	MGAL		
13	659	00300	TOPSOIL	143	CY		
14	659	10000	SEEDING AND MULCHING	1284	SY		
15	659	14000	REPAIR SEEDING AND MULCHING	64	SY		
16	659	20000	COMMERCIAL FERTILIZER	0.17	TON		
17	659	31000	LIME	0.27	ACRE		
18	659	35000	WATER	6.9	MGAL		
19	832	30000	EROSION CONTROL	20000	EACH		
EROSION CONTROL SUBTOTAL					\$		-
DRAINAGE							
20	605	06020	4" BASE PIPE UNDERDRAINS WITH GEOTEXTILE FABRIC	300	FT		
21	611	00410	4" CONDUIT, TYPE F FOR UNDERDRAIN OUTLET	20	FT		
22	611	00901	6" CONDUIT, TYPE B, AS PER PLAN, FOR DRAINAGE CONNECTION	100	FT		
23	611	04200	12" CONDUIT, TYPE A, 706.04	16	FT		

WAR-TR55-2.11 - PID 114603

24	611	05700	15" CONDUIT, TYPE A, 706.04	9	FT		
25	611	52400	22" X 34" CONDUIT, TYPE A 706.04	10	FT		
26	611	52700	29" X 45" CONDUIT, TYPE A 706.04	16	FT		
27	611	99574	MANHOLE, NO 3, AJUST TO GRADE	1	EACH		
DRAINAGE SUBTOTAL					\$		-
PAVEMENT							
28	204	10000	SUBGRADE COMPACTION	3064	SY		
29	301	56000	ASPHALT CONCRETE BASE, PG64-22, (449)	330	CY		
30	304	20000	AGGREGATE BASE	520	CY		
31	407	10000	TACK COAT	180	GAL		
32	441	70000	ASPHALT CONCRETE SURFACE COURSE, TYPE 1, (449), PG64-22	130	CY		
33	608	12000	5" CONCRETE WALK	476	SF		
34	608	52000	CURB RAMP, AS PER PLAN	108	SF		
35	609	26000	CURB, TYPE 6	26	FT		
PAVEMENT SUBTOTAL					\$		-
TRAFFIC CONTROL							
36	646	03100	GROUND MOUNTED SUPPORT, NO. 3 POST	66.5	FT		
37	646	84900	REMOVAL OF GROUND MOUNTED SIGN AND DISPOSAL	1	EACH		
38	646	85100	REMOVAL OF GOURND MOUNTED SIGN AND REERECTION	5	EACH		
39	646	85200	REMOVAL OF GOURND MOUNTED SIGN AND DELIVERY	1	EACH		
40	646	86002	REMOVAL OF GROUND MOUNTED POST SUPPORT AND DISPOSAL	1	EACH		
41	646	86002	LANE LINE, 6" TYPE 1	0.55	MILE		
TRAFFIC CONTROL SUBTOTAL					\$		-
RETAINING WALLS							
42	503	21100	UNCLASSIFIED EXCAVATION	345	CY		
43	451	13021	8" REINFORCED CONCRETE PAVEMENT, CLASS QC 1P WITH QC/QA, AS PER PLAN	18	SY		
44	509	10000	EPOXY COATED REINFORCING STEEL	6529	LB		
45	511	46213	CLASS QC1 CONCRETE, RETAINING/WINGWALL INCLUDING FOOTING, AS PER PLAN	93	CY		

WAR-TR55-2.11 - PID 114603

46	511	46612	CLASS QC1 CONCRETE WITH QC/QA, HEADWALL	24	CY		
47	518	21200	POURUS BACKFILL WITH GEOTEXTILE FABRIC	42	CY		
TRAFFIC SIGNAL SUBTOTAL					\$	-	
MAINTENANCE OF TRAFFIC							
48	614	12440	WORK ZONE SIGN SUPPORT	1	EACH		
49	614	22210	WORK ZONE EDGE LINE, CLASS I, 6", 740.06, TYPE I	1	MILE		
50	614	24404	WORK ZONE DOTTED LINE, CLASS I, 8", 740.06, TYPE I	200	FT		
51	614	300000	WORK ZONE ARROW, CLASS I	5	EACH		
52	614	31000	WORK ZONE WORD ON PAVEMENT, 72", CLASS I	4	EACH		
MAINTENANCE OF TRAFFIC SUBTOTAL					\$	-	
INCIDENTALS							
53	614	11000	MAINTAINING TRAFFIC	1	LUMP		
54	623	10000	CONSTRUCTION LAYOUT STAKES AND SURVEYING	1	LUMP		
55	624	10000	MOBILIZATION	1	LUMP		
MISCELLANEOUS SUBTOTAL					\$	-	
TOTAL AMOUNT				-			



Addendum #1
February 13, 2023

WAR TR55 2.11 (PID 114603)

Attached is the Bid Proposal (3 sheets) for the above referenced Project. A hard copy filled out by the contractor shall be submitted with the bid.

Also, available for your use upon request email from Dan Corey is a Bid Proposal excel spreadsheet (dan.corey@co.warren.oh.us).

WAR-TR55-2.11 - PID 114603

Ref No.	Item No.	Item Ext	Item Description	Quantity	Unit	Unit Price	Total Cost
ROADWAY							
1	201	11000	CLEARING AND GRUBBING, AS PER PLAN	1	LUMP		
2	202	20010	HEADWALL REMOVED	5	EACH		
3	202	30000	WALK REMOVED	9	SF		
4	202	32000	CURB REMOVED	45	FT		
5	203	10000	EXCAVATION	1246	CY		
6	203	20000	EMBANKMENT	646	CY		
7	209	60501	LINEAR GRADING, AS PER PLAN	1	MILE		
8	607	98000	FENCE, MISC.: DECORATIVE RAILING	379	FT		
9	611	99654	MANHOLE ADJUSTED TO GRADE	3	EACH		
10	661	99940	PLANTING, MISC.: TREE REPLACEMENT	1	LS		
11	878	25000	INSPECION AND COMPACTION TESTING OF UNBOUND MATERIALS	1	LS		
ROADWAY SUBTOTAL					\$		-
EROSION CONTROL							
12	616	10000	WATER	1	MGAL		
13	659	00300	TOPSOIL	143	CY		
14	659	10000	SEEDING AND MULCHING	1284	SY		
15	659	14000	REPAIR SEEDING AND MULCHING	64	SY		
16	659	20000	COMMERCIAL FERTILIZER	0.17	TON		
17	659	31000	LIME	0.27	ACRE		
18	659	35000	WATER	6.9	MGAL		
19	832	30000	EROSION CONTROL	20000	EACH		
EROSION CONTROL SUBTOTAL					\$		-
DRAINAGE							
20	605	06020	4" BASE PIPE UNDERDRAINS WITH GEOTEXTILE FABRIC	300	FT		
21	611	00410	4" CONDUIT, TYPE F FOR UNDERDRAIN OUTLET	20	FT		
22	611	00901	6" CONDUIT, TYPE B, AS PER PLAN, FOR DRAINAGE CONNECTION	100	FT		
23	611	04200	12" CONDUIT, TYPE A, 706.04	16	FT		

WAR-TR55-2.11 - PID 114603

24	611	05700	15" CONDUIT, TYPE A, 706.04	9	FT		
25	611	52400	22" X 34" CONDUIT, TYPE A 706.04	10	FT		
26	611	52700	29" X 45" CONDUIT, TYPE A 706.04	16	FT		
27	611	99574	MANHOLE, NO 3, AJUST TO GRADE	1	EACH		
DRAINAGE SUBTOTAL					\$		-
PAVEMENT							
28	204	10000	SUBGRADE COMPACTION	3064	SY		
29	301	56000	ASPHALT CONCRETE BASE, PG64-22, (449)	330	CY		
30	304	20000	AGGREGATE BASE	520	CY		
31	407	10000	TACK COAT	180	GAL		
32	441	70000	ASPHALT CONCRETE SURFACE COURSE, TYPE 1, (449), PG64-22	99	CY		
33	608	12000	5" CONCRETE WALK	476	SF		
34	608	52000	CURB RAMP, AS PER PLAN	108	SF		
35	609	26000	CURB, TYPE 6	26	FT		
PAVEMENT SUBTOTAL					\$		-
TRAFFIC CONTROL							
36	646	03100	GROUND MOUNTED SUPPORT, NO. 3 POST	66.5	FT		
37	646	84900	REMOVAL OF GROUND MOUNTED SIGN AND DISPOSAL	1	EACH		
38	646	85100	REMOVAL OF GOURND MOUNTED SIGN AND REERECTION	5	EACH		
39	646	85200	REMOVAL OF GOURND MOUNTED SIGN AND DELIVERY	1	EACH		
40	646	86002	REMOVAL OF GROUND MOUNTED POST SUPPORT AND DISPOSAL	1	EACH		
41	646	86002	LANE LINE, 6" TYPE 1	0.55	MILE		
TRAFFIC CONTROL SUBTOTAL					\$		-
RETAINING WALLS							
42	503	21100	UNCLASSIFIED EXCAVATION	345	CY		
43	451	13021	8" REINFORCED CONCRETE PAVEMENT, CLASS QC 1P WITH QC/QA, AS PER PLAN	18	SY		
44	509	10000	EPOXY COATED REINFORCING STEEL	6529	LB		
45	511	46213	CLASS QC1 CONCRETE, RETAINING/WINGWALL INCLUDING FOOTING, AS PER PLAN	93	CY		

WAR-TR55-2.11 - PID 114603

46	511	46612	CLASS QC1 CONCRETE WITH QC/QA, HEADWALL	24	CY		
47	518	21200	POURUS BACKFILL WITH GEOTEXTILE FABRIC	42	CY		
TRAFFIC SIGNAL SUBTOTAL					\$		-
MAINTENANCE OF TRAFFIC							
48	614	12440	WORK ZONE SIGN SUPPORT	1	EACH		
49	614	22210	WORK ZONE EDGE LINE, CLASS I, 6", 740.06, TYPE I	1	MILE		
50	614	24404	WORK ZONE DOTTED LINE, CLASS I, 8", 740.06, TYPE I	200	FT		
51	614	300000	WORK ZONE ARROW, CLASS I	5	EACH		
52	614	31000	WORK ZONE WORD ON PAVEMENT, 72", CLASS I	4	EACH		
MAINTENANCE OF TRAFFIC SUBTOTAL					\$		-
INCIDENTALS							
53	614	11000	MAINTAINING TRAFFIC	1	LUMP		
54	623	10000	CONSTRUCTION LAYOUT STAKES AND SURVEYING	1	LUMP		
55	624	10000	MOBILIZATION	1	LUMP		
MISCELLANEOUS SUBTOTAL					\$		-
TOTAL AMOUNT							-

PLAN HOLDERS LIST

WAR-TR 55-2.11 AKA Irwin Simpson Road Shared Use Path

Individuals or companies can be added to the plan holders list by contacting Krystal Powell at krystal.powell@co.warren.oh.us

Name	Company	Phone Number	E-mail Address
Roger Cadle	Prus Construction	513-321-7774	rcadle@prus.us
Lisa McNabb	W G Stang, LLC	513-863-6924	wgstang@cinci.rr.com
Tyler Holden	KT Holden Construction	513-200-3432	tholden@ktholden.com
Phil Tatum	Forix	317-435-3366	ptatum@earthwallproduct.com
Jen Foley	Sunesis Construction Co.	513-326-6000	jfoley@sunesiscc.com
Andrew Kloenne	Ford Development Corporation	513-772-1521	akloenne@forddevelopment.com
Amy Cox	Fillmore Construction LLC	937-780-1301	amy@fillmoreconstructionllc.com
Chad Baker	Rack and Ballauer Excavating Co. Inc.	513-738-7000 ext. 13	chadbakerb@gmail.com
Josh Campbell	John R. Jurgensen Company	513-326-3519	Josh.campbell@jrnet.com
Danyalle Hester	Performance Site Development	937-410-4645	danyallehester@gmail.com

STATE OF OHIO
 DEPARTMENT OF TRANSPORTATION
WAR-TR55-2.11
SHARED USE PATH
 WARREN COUNTY

PROJECT DESCRIPTION

CONSTRUCT SHARED USE TRAIL ALONG IRWIN SIMPSON FROM MASON MONTGOMERY ROAD TO THE EXISTING TRAIL JUST WEST OF DUKE BOULEVARD

PROJECT EARTH DISTURBED AREA: 0.96 ACRES
 ESTIMATED CONTRACTOR EARTH DISTURBED AREA: 0.02 ACRES
 NOTICE OF INTENT EARTH DISTURBED AREA: N/A (NOI not required)

2023 SPECIFICATIONS

THE STANDARD SPECIFICATIONS OF THE STATE OF OHIO, DEPARTMENT OF TRANSPORTATION, INCLUDING CHANGES AND SUPPLEMENTAL SPECIFICATIONS LISTED IN THE PROPOSAL SHALL GOVERN THIS IMPROVEMENT.

I HEREBY APPROVE THESE PLANS AND DECLARE THAT THE MAKING OF THIS IMPROVEMENT WILL NOT REQUIRE THE CLOSING TO TRAFFIC OF THE HIGHWAY AND THAT PROVISIONS FOR THE MAINTENANCE AND SAFETY OF TRAFFIC WILL BE AS SET FORTH ON THE PLANS AND ESTIMATES.

Neil F. Tunison

APPROVED: _____
 DATE 9/19/23 WARREN COUNTY ENGINEER
 NEIL F. TUNISON, P.E., P.S.

INDEX OF SHEETS:

COVER SHEET.....	01	FULL HEIGHT HEADWALL DETAILS.....	38
SCHEMATIC PLAN.....	02	HEADWALL PLAN VIEW.....	39
TYPICAL SECTIONS.....	03	HEADWALL CROSS SECTIONS.....	40-42
GENERAL NOTES.....	04-05	TRAFFIC CONTROL SUB-SUMMARY.....	43
MAINTENANCE OF TRAFFIC NOTES.....	06	TRAFFIC CONTROL PLAN.....	44-47
MAINTENANCE OF TRAFFIC SUB-SUMMARY.....	07	REINFORCED CONCRETE SECTION DETAILS.....	48
MAINTENANCE OF TRAFFIC PLAN.....	08-11	REINFORCED CONCRETE PLAN AND PROFILE.....	49
GENERAL SUMMARY.....	12-13	RETAINING WALL DETAILS.....	50
SUB-SUMMARIES.....	14	RETAINING WALL ELEVATIONS.....	51-52
PAVEMENT CALCULATIONS.....	15	RETAINING WALL PLAN AND PROFILE.....	53-54
PLAN AND PROFILE SHEETS.....	16-21	RIGHT OF WAY PLANS.....	55-71
CROSS SECTIONS.....	22-35		
INTERSECTION DETAILS.....	36		
DETAIL GRADING.....	37		

FINAL PLANS



LOCATION MAP

LATITUDE: 39°18'36.39" LONGITUDE: -84°18'49.41"

NOT TO SCALE

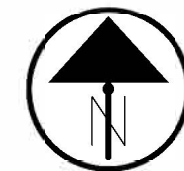

- PORTION TO BE IMPROVED.....
- INTERSTATE HIGHWAY.....
- FEDERAL ROUTES.....
- STATE ROUTES.....
- COUNTY & TOWNSHIP ROADS.....
- OTHER ROADS.....

DESIGN DESIGNATION

- CURRENT ADT (2022).....
- DESIGN YEAR ADT (2022).....
- DESIGN HOURLY VOLUME (2022).....
- DIRECTIONAL DISTRIBUTION.....
- TRUCKS (24 HOUR B&C).....
- DESIGN SPEED..... 15 MPH
- LEGAL SPEED..... 15 MPH
- DESIGN FUNCTIONAL CLASSIFICATION:.....

NHS PROJECT.....

DESIGN EXCEPTIONS NONE REQUIRED

ADA DESIGN WAIVERS NONE REQUIRED

UNDERGROUND UTILITIES
 CONTACT TWO WORKING DAYS BEFORE YOU DIG.

 OHIO811, 8-1-1, OR 1-800-362-2764 (Non-members must be called directly)

PLAN PREPARED BY:
KZF DESIGN
 Designing Better Futures
 700 Broadway Street TEL 513 621 6211
 Cincinnati, OH 45202-6010 FAX 513 621 6530

ENGINEERS SEAL:

STATE OF OHIO
 SHAWN RICHARDS
 E-87358
 REGISTERED PROFESSIONAL ENGINEER
 Digitally signed by Shawn Richards
 Date: 2023.06.29 11:25:18-04'00'

ENGINEERS SEAL:

STATE OF OHIO
 TED WILLIAM VERST
 E-70519
 REGISTERED PROFESSIONAL ENGINEER
 Digitally signed by Ted Verst
 Date: 2023.06.29 13:01:16-04'00'

STANDARD CONSTRUCTION DRAWINGS				SUPPLEMENTAL SPECIFICATIONS	SPECIAL PROVISIONS
BP-3.1	1/21/22	MT-95.31	7/19/19	800 4/21/23	
BP-5.1	7/15/22	MT-99.20	4/19/19	832 7/15/22	
BP-7.1	1/20/23	MT-101.90	7/17/20	863 10/21/22	
		MT-105.10	1/17/20	871 4/15/05	
DM-1.1	7/17/20	MT-110.10	7/19/13	878 1/21/22	
DM-4.2	7/20/12			880 1/21/22	
DM-4.3	1/15/16	TC-41.20	10/18/13	884 10/19/18	
DM-4.4	1/15/16	TC-42.20	10/18/13		
HW-1.1	7/20/18	LA-1.2	1/16/09		
HW-2.2	7/20/18				

F:\Projects\688800\05_Deliverables\Drawings\114603\Design\Roadway\Sheets\114603GT001.dwg 29-Jun-23 10:21 AM

FEDERAL PROJECT NO. E230029
 CONSTRUCTION PROJECT NO. N/A
 RAILROAD INVOLVEMENT NONE
 PID NO. 114603
 WAR-TR55-2.11
 01
 71

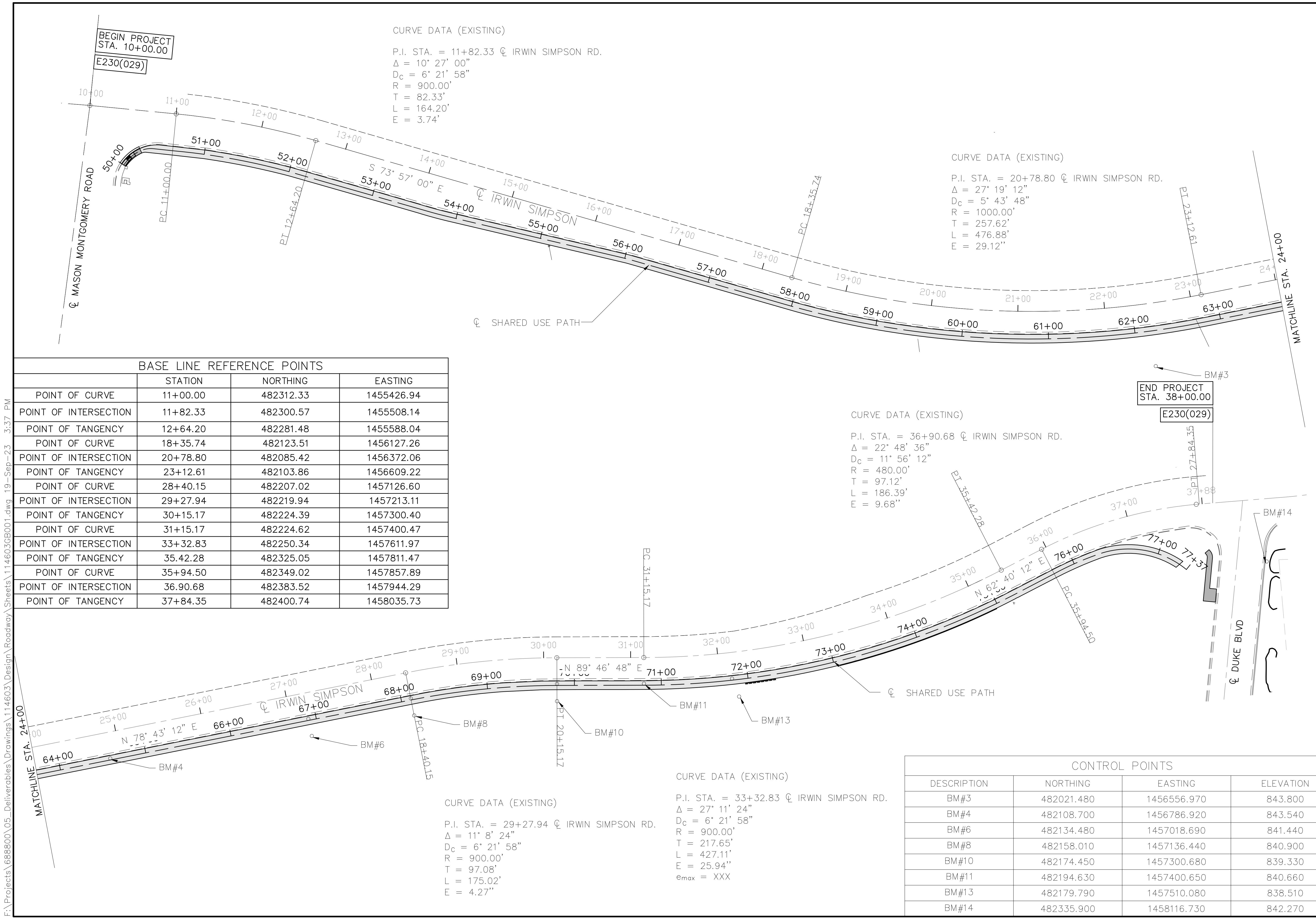

CURVE DATA (EXISTING)

P.I. STA. = 11+82.33 ϕ IRWIN SIMPSON RD.
 $\Delta = 10^\circ 27' 00''$
 $D_c = 6^\circ 21' 58''$
 $R = 900.00'$
 $T = 82.33'$
 $L = 164.20'$
 $E = 3.74'$

CURVE DATA (EXISTING)

P.I. STA. = 20+78.80 ϕ IRWIN SIMPSON RD.
 $\Delta = 27^\circ 19' 12''$
 $D_c = 5^\circ 43' 48''$
 $R = 1000.00'$
 $T = 257.62'$
 $L = 476.88'$
 $E = 29.12''$

CURVE DATA (EXISTING)

P.I. STA. = 36+90.68 ϕ IRWIN SIMPSON RD.
 $\Delta = 22^\circ 48' 36''$
 $D_c = 11^\circ 56' 12''$
 $R = 480.00'$
 $T = 97.12'$
 $L = 186.39'$
 $E = 9.68''$

CURVE DATA (EXISTING)

P.I. STA. = 29+27.94 ϕ IRWIN SIMPSON RD.
 $\Delta = 11^\circ 8' 24''$
 $D_c = 6^\circ 21' 58''$
 $R = 900.00'$
 $T = 97.08'$
 $L = 175.02'$
 $E = 4.27''$

CURVE DATA (EXISTING)

P.I. STA. = 33+32.83 ϕ IRWIN SIMPSON RD.
 $\Delta = 27^\circ 11' 24''$
 $D_c = 6^\circ 21' 58''$
 $R = 900.00'$
 $T = 217.65'$
 $L = 427.11'$
 $E = 25.94''$
 $e_{max} = XXX$

BASE LINE REFERENCE POINTS

	STATION	NORTHING	EASTING
POINT OF CURVE	11+00.00	482312.33	1455426.94
POINT OF INTERSECTION	11+82.33	482300.57	1455508.14
POINT OF TANGENCY	12+64.20	482281.48	1455588.04
POINT OF CURVE	18+35.74	482123.51	1456127.26
POINT OF INTERSECTION	20+78.80	482085.42	1456372.06
POINT OF TANGENCY	23+12.61	482103.86	1456609.22
POINT OF CURVE	28+40.15	482207.02	1457126.60
POINT OF INTERSECTION	29+27.94	482219.94	1457213.11
POINT OF TANGENCY	30+15.17	482224.39	1457300.40
POINT OF CURVE	31+15.17	482224.62	1457400.47
POINT OF INTERSECTION	33+32.83	482250.34	1457611.97
POINT OF TANGENCY	35.42.28	482325.05	1457811.47
POINT OF CURVE	35+94.50	482349.02	1457857.89
POINT OF INTERSECTION	36.90.68	482383.52	1457944.29
POINT OF TANGENCY	37+84.35	482400.74	1458035.73

CONTROL POINTS

DESCRIPTION	NORTHING	EASTING	ELEVATION
BM#3	482021.480	1456556.970	843.800
BM#4	482108.700	1456786.920	843.540
BM#6	482134.480	1457018.690	841.440
BM#8	482158.010	1457136.440	840.900
BM#10	482174.450	1457300.680	839.330
BM#11	482194.630	1457400.650	840.660
BM#13	482179.790	1457510.080	838.510
BM#14	482335.900	1458116.730	842.270

F:\Projects\688800\05_Deliverables\Drawings\114603\Roadway\Sheets\114603GB001.dwg 19-Sep-23 3:37 PM

F:\Projects\688800\05_Deliverables\Drawings\Roadway\Sheets\114603GY001.dwg, 19-Sep-23 3:37 PM

CALCULATED
SCR
CHECKED
NW

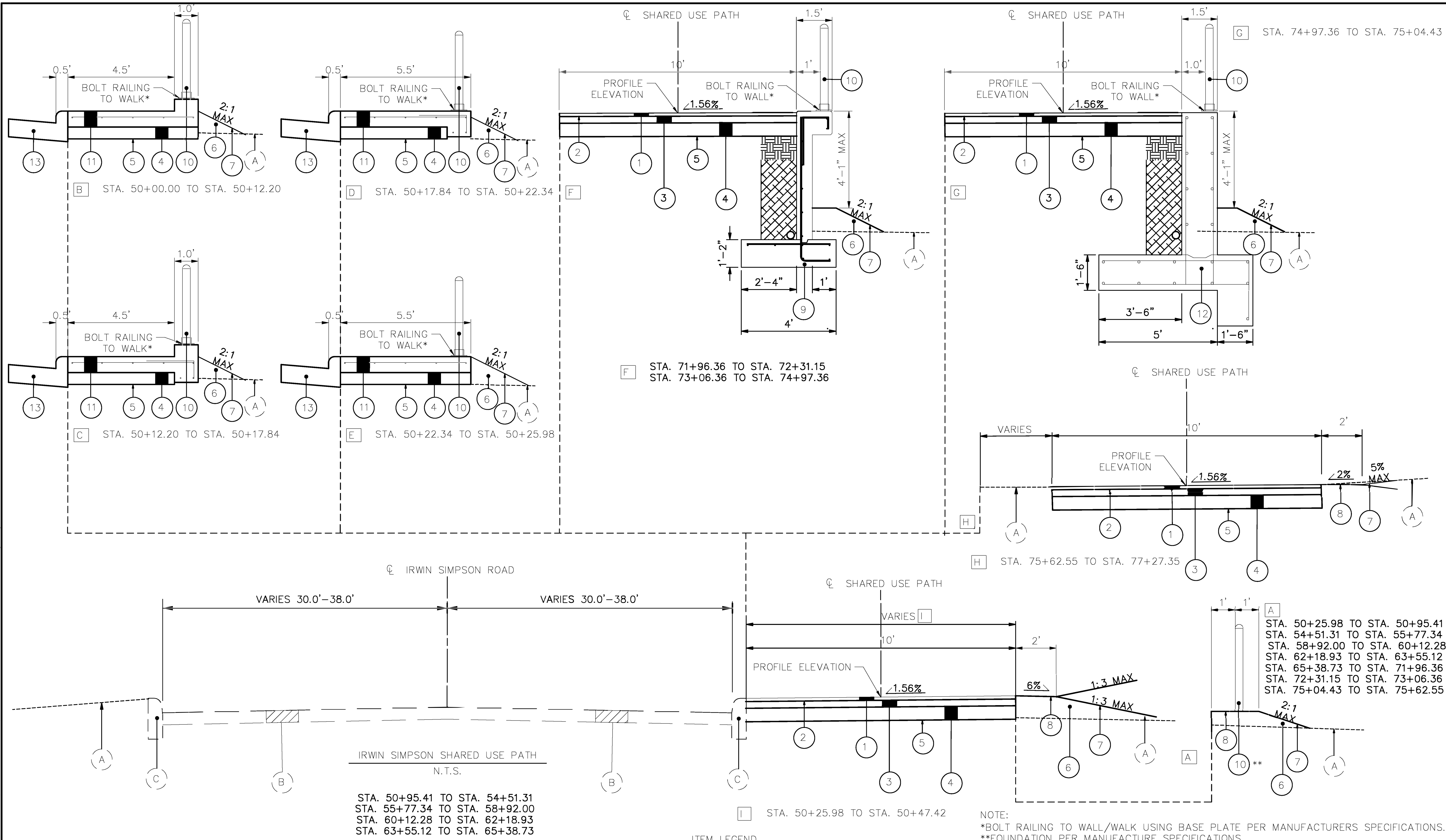

TYPICAL SECTIONS

WAR-TR55-2.11

- | | | | | | | | |
|---|---|---|--|----|---|----|---|
| 1 | ITEM 441 - 1 1/2" ASPHALT CONCRETE SURFACE COURSE, TYPE 1, (449), PG64-22 | 5 | ITEM 204 - SUBGRADE COMPACTION | 9 | ITEM 511 - CLASS QC1 CONCRETE WITH QC/QA, RETAINING/WINGWALL INCLUDING FOOTING, AS PER PLAN | 13 | ITEM 609 - COMBINATION CURB AND GUTTER TYPE 2 |
| 2 | ITEM 407 - TACK COAT (APPLIED @ 0.06 GAL/SQ YD) | 6 | ITEM 653 - TOPSOIL | 10 | ITEM 607 - FENCE MISC.: RAILING | A | EXISTING GRADE |
| 3 | ITEM 301 - 3" ASPHALT CONCRETE BASE, (449), PG64-22 | 7 | ITEM 659 - SEEDING AND MULCHING | 11 | ITEM 451 - 8" REINFORCED CONCRETE PAVEMENT, CLASS QC 1P WITH QC/QA, AS PER PLAN, SEE SHEET 48 | B | EXISTING IRWIN SIMPSON ROAD |
| 4 | ITEM 304 - 6" AGGREGATE BASE | 8 | ITEM 209 - LINEAR GRADING, AS PER PLAN | 12 | ITEM 511 - CLASS QC CONCRETE WITH, QC/QA HEADWALL, AS PER PLAN, SEE SHEET 38 | C | EXISTING CURB |

NOTE:
*BOLT RAILING TO WALL/WALK USING BASE PLATE PER MANUFACTURERS SPECIFICATIONS.
**FOUNDATION PER MANUFACTURE SPECIFICATIONS.

F:\Projects\688800\05_Deliverables\Drawings\114603\Design\Roadway\Sheets\114603GN001.dwg 19-Sep-23 3:38 PM

UTILITY OWNERSHIP

LISTED BELOW ARE ALL UTILITIES LOCATED WITHIN THE PROJECT CONSTRUCTION LIMITS TOGETHER WITH THEIR RESPECTIVE OWNERS:

- TELEPHONE----- AT&T
2024 VALLEY ST
DAYTON, OH 45404
PHONE: (614) 392-2873
- SEWER----- WARREN CTY WATER & SEWER
406 Justice Dr,
Lebanon, OH 45036
PHONE: 513-695-1377
- WATER----- WARREN CTY WATER & SEWER
406 Justice Dr,
Lebanon, OH 45036
PHONE: 513-695-1377
- ELECTRIC----- DUKE ENERGY
139 E 4th St
CINCINNATI, OHIO 45202
PHONE: 800-544-6900
- GAS----- DUKE ENERGY
139 E 4th St
CINCINNATI, OHIO 45202
PHONE: 800-544-6900
- FIBER OPTICS ----- AT&T - ATT/T (AT&T TRANSMISSION)
525 VINE ST.
ROOM 407
CINCINNATI, OH 45202
CONTACT: SCOTT MERGLER
PHONE: 513-277-4655
- CHARTER COMM
(SPECTRUM/TIMEWARNER)/USIC
11252 CORNELL PARK DRIVE
OHIO 45242-1886
PHONE: 513-469-5483
- CINCINNATI BELL (USIC)
201 EAST FOURTH ST.
ML 103-1175
CINCINNATI, OHIO 45202
PHONE: 513-565-7043
- CTLCL - CENTURYLINK (USIC)
205 W 4TH ST.
CINCINNATI, OH 45202
CONTACT: JOSH MOTZER
PHONE: 513-241-6719

ITEM 209 - LINEAR GRADING, AS PER PLAN

PROVIDE GRADING ALONG FROM THE EDGE OF PATH TO 2' OUT EACH SIDE WITHOUT CURB, IN PREPARATION FOR ITEM 653 TOPSOIL. ALL OTHER ITEMS WITH REGARDS TO ITEM 209: LINEAR GRADING SHALL APPLY.

WORK LIMITS

THE WORK LIMITS SHOWN ON THESE PLANS ARE FOR PHYSICAL CONSTRUCTION ONLY. PROVIDE THE INSTALLATION AND OPERATION OF ALL WORK ZONE TRAFFIC CONTROL AND WORK ZONE TRAFFIC CONTROL DEVICES REQUIRED BY THESE PLANS WHETHER INSIDE OR OUTSIDE THESE WORK LIMITS.

SURVEYING

PRIMARY PROJECT CONTROL MONUMENTS GOVERN ALL POSITIONING ON ODOT PROJECTS. SEE SHEET 02 OF THE PLANS FOR A TABLE CONTAINING PROJECT CONTROL INFORMATION.

USE THE FOLLOWING PROJECT CONTROL, VERTICAL POSITION, AND HORIZONTAL POSITIONING PARAMETERS FOR ALL SURVEYING:

PROJECT CONTROL

VERTICAL POSITIONING

ORTHOMETRIC HEIGHT DATUM: NAVD 88
GEOID: 12A

HORIZONTAL POSITIONING

REFERENCE FRAME: NAD83 (86)
ELLIPSOID: GRS80
MAP PROTECTION: LAMBERT
COORDINATION SYSTEM: STATE OF PLANE OH SOUTH
1.000094421104

USE THE POSITIONING METHODS AND MONUMENT TYPE USED IN THE ORIGINAL SURVEY TO RESTORE ALL MONUMENTS RELATED TO PRIMARY PROJECT CONTROL THAT ARE DAMAGED OR DESTROYED BY CONSTRUCTION ACTIVITIES. RESTORE THE DAMAGED OR DESTROYED MONUMENTS IN ACCORDANCE WITH SUPPLEMENTAL SPECIFICATION 823.

EXISTING FACILITIES

IT SHALL BE THE RESPONSIBILITY OF THE CONTRACTOR TO PERFORM THEIR WORK IN SUCH MANNER AS NOT TO DAMAGE OR DESTROY ANY EXISTING FACILITY. IF ANY DAMAGE TO ANY EXISTING FACILITY OCCURS DUE TO THE CONTRACTOR'S OPERATIONS, THEY SHALL REPLACE THE DAMAGED FACILITY AT THEIR EXPENSE AND TO THE SATISFACTION OF THE ENGINEER.

CLEARING AND GRUBBING, AS PER PLAN

ALTHOUGH THERE ARE NO TREES OR STUMPS SPECIFICALLY MARKED FOR REMOVAL WITHIN THE LIMITS OF THE PROJECT, A LUMP SUM QUANTITY IS INCLUDED IN THE GENERAL SUMMARY FOR ITEM 201, CLEARING AND GRUBBING. ALL PROVISIONS AS SET FORTH IN THE SPECIFICATIONS UNDER THIS ITEM ARE INCLUDED IN THE LUMP SUM PRICE BID FOR ITEM 201, CLEARING AND GRUBBING, AS PER PLAN

OWNER SHALL APPROVE THE REMOVAL OF ALL TREES INCLUDING THOSE LESS THAN 12" LOCATED BETWEEN THE TEMPORARY RIGHT OF WAY AND PERMANENT RIGHT OF WAY.

ITEM 661, PLANTING, MISC; TREE REPLACEMENT.

ALTHOUGH THERE ARE NO TREE PLANTINGS SPECIFICALLY MARKED IN THE PLANS, A LUMP SUM QUANTITY IS INCLUDED IN THE GENERAL SUMMARY FOR ITEM 661, PLANTING, MISC; TREE REPLACEMENT.

CONTRACTOR SHALL SUPPLY AND PLANT ONE 3" CALIPER TREE FOR EVERY TREE REMOVED DURING CONSTRUCTION. TYPE AND LOCATION OF TREE SHALL BE APPROVED BY THE OWNER PRIOR TO INSTALLATION.

THE UNIT BID PRICE SHALL INCLUDE ALL LABOR, MATERIALS, EQUIPMENT TO COMPLETE WORK FOR: ITEM 661, PLANTING, MISC; TREE REPLACEMENT.

SEEDING AND MULCHING

THE FOLLOWING QUANTITIES ARE PROVIDED TO PROMOTE GROWTH AND CARE OF PERMANENT SEEDED AREAS:

659, TOPSOIL	143 CU. YD.
659, SEEDING AND MULCHING	1284 SQ. YD.
659, REPAIR SEEDING AND MULCHING	64 SQ. YD.
659, COMMERCIAL FERTILIZER	0.17 TON
659, LIME	0.27 ACRE
659, WATER	6.9 M. GAL.

NOTIFICATION OF TRAFFIC RESTRICTIONS

THROUGHOUT THE DURATION OF THE PROJECT, THE CONTRACTOR SHALL NOTIFY THE PROJECT ENGINEER IN WRITING OF ALL TRAFFIC RESTRICTIONS AND UPCOMING MAINTENANCE OF TRAFFIC CHANGES. THE CONTRACTOR SHALL ENSURE THE WRITTEN NOTIFICATION IS SUBMITTED IN A TIMELY MANNER TO ALLOW THE PROJECT ENGINEER TO MEET THE REQUIRED TIME FRAMES SET FORTH IN THE TABLE BELOW TO INFORM THE OFFICE OF COMMUNICATIONS. THIS NOTIFICATION SHALL BE RECEIVED BY THE PROJECT ENGINEER PRIOR TO THE PHYSICAL SETUP OF ANY APPLICABLE SIGNS OR MESSAGE BOARDS.

INFORMATION SHOULD INCLUDE, BUT IS NOT LIMITED TO, ALL CONSTRUCTION ACTIVITIES THAT IMPACT OR INTERFERE WITH TRAFFIC AND SHALL LIST THE SPECIFIC LOCATION, TYPE OF WORK, ROAD STATUS, DATE AND TIME OF RESTRICTION, DURATION OF RESTRICTION, NUMBER OF LANES MAINTAINED, NUMBER OF LANES CLOSED, DETOUR ROUTES, IF APPLICABLE, AND ANY OTHER INFORMATION REQUESTED BY THE PROJECT ENGINEER.

NOTICE TO OFFICE OF COMMUNICATIONS TIME TABLE		
ITEM	DURATION OF CLOSURE	NOTICE DUE TO OFFICE OF COMMUNICATION
RAMP & ROAD CLOSURES	>= 2 WEEKS	21 CALENDAR DAYS PRIOR TO CLOSURE
	>12 HOURS & < 2 WEEKS	14 CALENDAR DAYS PRIOR TO CLOSURE
	< 12 HOURS	4 BUSINESS DAYS PRIOR TO CLOSURE
LANE CLOSURES AND RESTRICTIONS	>= 2 WEEKS	14 CALENDAR DAYS PRIOR TO CLOSURE
	< 2 WEEKS	2 BUSINESS DAYS PRIOR TO CLOSURE
START OF CONSTRUCTION & TRAFFIC PATTERN CHANGES	N/A	14 CALENDAR DAYS PRIOR TO IMPLEMENTATION

ANY UNFORESEEN CONDITIONS NOT SPECIFIED IN THE PLANS REQUIRING TRAFFIC RESTRICTIONS SHALL ALSO BE REPORTED TO THE PROJECT ENGINEER USING THE NOTICE TO OFFICE OF COMMUNICATIONS TIME TABLE.

AIRWAY/HIGHWAY CLEARANCE FOR PUBLIC AIRPORTS

AIRWAY/HIGHWAY CLEARANCE FOR PUBLIC AIRPORTS THIS PROJECT HAS BEEN IDENTIFIED AS BEING WITHIN THE INFLUENCE AREA OF ONE (1) PUBLIC USE AIRPORTS WHICH IS LISTED IN THE TABLE BELOW. NO TEMPORARY STRUCTURES OR CONSTRUCTION EQUIPMENT AT MAXIMUM OPERATING HEIGHT SHALL EXCEED THE HEIGHTS (Z) PROVIDED IN THE TABLE BELOW:

POTENTIALLY IMPACTED AIRPORTS	AIRPORT ELEVATION "A"	PROJECT ELEVATION "B" + 25 feet (Controlling Criteria)	DISTANCE BETWEEN AIRPORT & PROJECT "C"	NOTIFICATION SLOPE X:1	USE TYPE	AMOUNT OF CLEARANCE ABOVE NOTIFICATION SLOPE "Z"
C.C.A. HELIPORT (90H3)	810 ft.	845 FT + 25 FT = 870 FT	9830 FT	25:1	PRIVATE	333.2 FEET

IF ANY TEMPORARY STRUCTURES OR CONSTRUCTION EQUIPMENT WILL EXCEED THESE HEIGHTS, FURTHER COORDINATION WITH THE FEDERAL AVIATION ADMINISTRATION (FAA), AND ODOT OFFICE OF AVIATION, WILL BE NECESSARY PRIOR TO ERECTING SUCH TEMPORARY STRUCTURES OR OPERATING SUCH EQUIPMENT ON THE PROJECT. THE CONTRACTOR WILL BE REQUIRED TO SUBMIT FORM 7460-1 TO THE FAA. NOTIFY THE ODOT OFFICE OF AVIATION WHEN SUBMITTING FAA FORM 7460-1. NO TEMPORARY STRUCTURES OR CONSTRUCTION EQUIPMENT SHALL EXCEED THE PERMISSIBLE HEIGHT, UNTIL A COPY OF THE FAA APPROVAL AND THE ODOT OFFICE OF AVIATION PERMIT HAS BEEN FURNISHED TO THE PROJECT ENGINEER.

FAA CONTACT INFORMATION:
EXPRESS PROCESSING CENTER
THE FEDERAL AVIATION ADMINISTRATION
SOUTHWEST REGIONAL OFFICE
AIR TRAFFIC AIRSPACE BRANCH ASW-520
2601 MEACHAN BLVD.
FORT WORTH, TX 76137-4298

ODOT OFFICE OF AVIATION CONTACT INFORMATION:
OHIO DEPARTMENT OF TRANSPORTATION OFFICE OF AVIATION
2829 WEST DUBLIN-GRANVILLE ROAD
COLUMBUS, OHIO 43235
(614)-387-2346

ITEM 607 - FENCE MISC: DECORATIVE RAILING, AS PER PLAN

THIS ITEM SHALL INCLUDE THE FURNISHING AND INSTALLING OF DECORATIVE RAILING MATCHING THE TEXTURE, STYLE, COLOR, AND MATERIAL OF THE DECORATIVE RAILING ON THE NORTHEAST CORNER OF MASON-MONTGOMERY ROAD AND IRWIN SIMPSON ROAD AS CLOSELY AS POSSIBLE.

THE CONTRACTOR SHALL PROVIDE SHOP DRAWINGS OF THE PROPOSED RAILING INCLUDING STYLE, MATERIAL, COLOR, COMPONENTS, DIMENSIONS, ACCESSORIES, AND FOUNDATION MATERIAL FOR APPROVAL PRIOR TO ORDERING MATERIAL. FOUNDATION SUBMITTALS SHALL INCLUDE OPTIONS FOR BOTH IN GROUND AND TOP OF WALL MOUNTING FOR APPROVAL.

THE CONTRACTOR IS TO PROVIDE A 3 YEAR WARRANTY FOR FACTORY FINISH AGAINST CRACKING, PEELING, AN BLISTERING UNDER NORMAL USE.

THE UNIT BID PRICE SHALL INCLUDE ALL LABOR, MATERIALS, EQUIPMENT TO COMPLETE WORK FOR: ITEM 607: FENCE MISC: DECORATIVE RAILING, AS PER PLAN

CALCULATED
SCR
CHECKED
NW

GENERAL NOTES

WAR - TR55 - 2.11

F:\Projects\688800\05_Deliverables\Drawings\114603\Design\Roadway\Sheets\114603GN001.dwg 19-Sep-23 3:38 PM

REVIEW OF DRAINAGE FACILITIES

BEFORE ANY WORK IS STARTED ON THE PROJECT AND AGAIN BEFORE FINAL ACCEPTANCE BY THE STATE, REPRESENTATIVES OF THE STATE AND THE CONTRACTOR, ALONG WITH LOCAL REPRESENTATIVES, SHALL MAKE AN INSPECTION OF ALL EXISTING SEWERS WHICH ARE TO REMAIN IN SERVICE AND WHICH MAY BE AFFECTED BY THE WORK. THE CONDITION OF THE EXISTING CONDUITS AND THEIR APPURTENANCE SHALL BE DETERMINED FROM FIELD OBSERVATIONS. RECORDS OF THE INSPECTION SHALL BE KEPT IN WRITING BY THE STATE.

ALL NEW CONDUITS, INLETS, CATCH BASINS, AND MANHOLES CONSTRUCTED AS A PART OF THE PROJECT SHALL BE FREE OF ALL FOREIGN MATTER AND IN A CLEAN CONDITION BEFORE THE PROJECT WILL BE ACCEPTED BY THE STATE.

ALL EXISTING SEWERS INSPECTED INITIALLY BY THE ABOVE MENTIONED PARTIES SHALL BE MAINTAINED AND LEFT IN A CONDITION REASONABLY COMPARABLE TO THAT DETERMINED BY THE ORIGINAL INSPECTION. ANY CHANGE IN THE CONDITION RESULTING FROM THE CONTRACTOR'S OPERATIONS SHALL BE CORRECTED BY THE CONTRACTOR TO THE SATISFACTION OF THE ENGINEER.

PAYMENT FOR ALL OPERATIONS DESCRIBED ABOVE SHALL BE INCLUDED IN THE CONTRACT PRICE FOR THE PERTINENT 611 CONDUIT ITEMS

UNRECORDED STORM WATER DRAINAGE

FURNISH A CONTINUANCE FOR ALL UNRECORDED STORM WATER DRAINAGE, SUCH AS ROOF DRAINS, FOOTER DRAINS, OR YARD DRAINS, DISTURBED BY THE WORK. FURNISH EITHER AN OPEN CONTINUANCE OR AN UNOBSTRUCTED CONTINUANCE BY CONNECT-STRUCTURE. THE LOCATION, TYPE, SIZE AND GRADE OF THE NEEDED CONDUIT TO REPLACE OR EXTEND AN EXISTING DRAIN WILL BE DETERMINED BY THE ENGINEER. ALL SUCH CONTINUANCE REQUIRES A RIGHT OF WAY USE PERMIT.

THE FOLLOWING CONDUIT TYPES MAY BE USED: 707.33, 707.41 NON-PERFORATED, 707.42, 707.43, 707.45, 707.46, 707.47, 707.51, 707.52 SDR35.

THE FOLLOWING ESTIMATED QUANTITIES HAVE BEEN INCLUDED IN THE GENERAL SUMMARY FOR USE AS DIRECTED BY THE ENGINEER FOR THE WORK NOTED ABOVE:

611, 6" CONDUIT, TYPE B, AS PER PLAN, FOR DRAINAGE CONNECTION 100 FT

ITEM 611 - 22"x34" CONDUIT, TYPE A, 706.04, AS PER PLAN

CONTRACTOR TO VERIFY SIZE OF EXISTING PIPE AND NOTIFY ENGINEER OF ANY DISCREPANCIES PRIOR TO ORDERING MATERIAL.

THE UNIT BID PRICE SHALL INCLUDE ALL LABOR, MATERIALS, EQUIPMENT TO COMPLETE WORK FOR: ITEM 611 - 22"x34" CONDUIT, TYPE A, 706.04, AS PER PLAN

ITEM 611 - 29"x45" CONDUIT, TYPE A, 706.04, AS PER PLAN

CONTRACTOR TO VERIFY SIZE OF EXISTING PIPE AND NOTIFY ENGINEER OF ANY DISCREPANCIES PRIOR TO ORDERING MATERIAL.

THE UNIT BID PRICE SHALL INCLUDE ALL LABOR, MATERIALS, EQUIPMENT TO COMPLETE WORK FOR: ITEM 611 - 29"x45" CONDUIT, TYPE A, 706.04, AS PER PLAN

CROSSINGS AND CONNECTIONS TO EXISTING PIPES AND UTILITIES

WHERE PLANS PROVIDE FOR A PROPOSED CONDUIT TO BE CONNECTED TO, OR CROSS OVER OR UNDER AN EXISTING SEWER OR UNDERGROUND UTILITY, THE CONTRACTOR SHALL LOCATE THE EXISTING PIPES OR UTILITIES BOTH AS TO LINE AND GRADE BEFORE STARTING TO LAY THE PROPOSED CONDUIT

IF IT IS DETERMINED THAT THE ELEVATION OF THE EXISTING CONDUIT, OR EXISTING APPURTENANCE TO BE CONNECTED, DIFFERS FROM THE PLAN ELEVATION OR RESULTS IN A CHANGE IN THE PLAN CONDUIT SLOPE, THE ENGINEER SHALL BE NOTIFIED BEFORE STARTING CONSTRUCTION OF ANY PORTION OF THE PROPOSED CONDUIT WHICH WILL BE AFFECTED BY THE VARIANCE IN THE EXISTING ELEVATIONS.

IF IT IS DETERMINED THAT THE PROPOSED CONDUIT WILL INTERSECT AN EXISTING SEWER OR UNDERGROUND UTILITY IF CONSTRUCTED AS SHOWN ON THE PLAN, THE ENGINEER SHALL BE NOTIFIED BEFORE STARTING CONSTRUCTION OF ANY PORTION OF THE PROPOSED CONDUIT WHICH WOULD BE AFFECTED BY THE INTERFERENCE WITH AN EXISTING FACILITY.

PAYMENT FOR ALL THE OPERATIONS DESCRIBED ABOVE SHALL BE INCLUDED IN THE CONTRACT PRICE FOR THE PERTINENT 611 CONDUIT ITEM.

4(F) COMMENTS

THE CONTRACTOR SHALL NOT PERFORM WORK WITHIN THE JURISDICTIONAL BOUNDARIES OF ANY WATERWAY, INCLUDING WETLANDS, UNTIL THE NECESSARY WATERWAY PERMIT(S) ARE OBTAINED. THIS INCLUDES THE PLACEMENT OF ANY TEMPORARY OR PERMANENT FILLS.

THE FOLLOWING SECTION 4(F) MEASURES TO MINIMIZE HARM WILL BE ADDED AS PROJECT PLAN NOTES TO ADDRESS IMPACTS TO SCHAPPACHER PARK:

- ACCESS TO SCHAPPACHER PARK SHALL BE MAINTAINED AT ALL TIMES.
- THE STAGING AND/OR STORAGE OF CONSTRUCTION EQUIPMENT OR MATERIALS SHALL NOT TAKE PLACE OUTSIDE PROPOSED CONSTRUCTION LIMITS THAT ARE WITHIN THE DEFINED BOUNDARIES OF SCHAPPACHER PARK.
- THE CONTRACTOR SHALL BE REQUIRED TO CLOSELY COORDINATE THE CONSTRUCTION SCHEDULE WITH DEERFIELD TOWNSHIP PARKS & RECREATION PRIOR TO THE START OF CONSTRUCTION ACTIVITIES.

CALCULATED
SCR
CHECKED
NW

GENERAL NOTES

WAR - TR55 - 2.11

05
71

F:\Projects\888800\05_Deliverables\Drawings\114603\Design\MOT\Sheets\114603\MN001.dwg 19-Sep-23 3:38 PM

ITEM 614, MAINTAINING TRAFFIC.

A MINIMUM OF 1 LANE(S) OF TRAFFIC IN EACH DIRECTION SHALL BE MAINTAINED AT ALL TIMES BY USE OF THE EXISTING PAVEMENT.

SINGLE LANE CLOSURES SHALL BE MADE IN ACCORDANCE WITH STANDARD CONSTRUCTION DRAWINGS MT-95.31

LENGTH AND DURATION OF LANE CLOSURES AND RESTRICTIONS SHALL BE AT THE APPROVAL OF THE ENGINEER. IT IS THE INTENT TO MINIMIZE THE IMPACT TO THE TRAVELING PUBLIC. LANE CLOSURES OR RESTRICTIONS OVER SEGMENTS OF THE PROJECT IN WHICH NO WORK IS ANTICIPATED WITHIN A REASONABLE TIME FRAME, AS DETERMINED BY THE ENGINEER, SHALL NOT BE PERMITTED. THE LEVEL OF UTILIZATION OF MAINTENANCE OF TRAFFIC DEVICES SHALL BE COMMENSURATE WITH THE WORK IN PROGRESS.

TRAFFIC SHALL BE MAINTAINED AT ALL INTERSECTIONS AND DRIVES AT ALL TIMES AND SHALL BE CONTROLLED BY TRAFFIC CONTROL DEVICES AS REQUIRED AND SHALL BE SUBJECT TO THE APPROVAL OF THE ENGINEER.

ALL WORK AND TRAFFIC CONTROL DEVICES SHALL BE IN ACCORDANCE WITH C&MS 614 AND OTHER APPLICABLE PORTIONS OF THE SPECIFICATIONS, AS WELL AS THE OHIO MANUAL OF UNIFORM TRAFFIC CONTROL DEVICES. PAYMENT FOR ALL LABOR, EQUIPMENT AND MATERIALS SHALL BE INCLUDED IN THE LUMP SUM CONTRACT PRICE FOR ITEM 614, MAINTAINING TRAFFIC, UNLESS SEPARATELY ITEMIZED IN THE PLAN.

OVERNIGHT TRENCH CLOSING.

THE BASE WIDENING SHALL BE COMPLETED TO A DEPTH OF NO MORE THAN 12 INCHES BELOW THE EXISTING PAVEMENT BY THE END OF EACH WORK DAY. NO TRENCH SHALL BE LEFT OPEN OVERNIGHT EXCEPT FOR A SHORT LENGTH (25 FEET OR LESS) OF A WORK SECTION AT THE END OF THE TRENCH. IN CASE WORK MUST BE SUSPENDED BECAUSE OF INCLEMENT WEATHER OR OTHER REASONS, THE TRENCH FOR THE UN-COMPLETED BASE WIDENING SHALL BE BACKFILLED AT THE DIRECTION OF THE ENGINEER.

FLOODLIGHTING

FLOODLIGHTING OF THE WORK SITE FOR OPERATIONS CONDUCTED DURING NIGHT TIME PERIODS SHALL BE ACCOMPLISHED SO THAT THE LIGHTS DO NOT CAUSE GLARE TO THE DRIVERS ON THE ROADWAY. TO ENSURE THE ADEQUACY OF THE FLOODLIGHT PLACEMENT, THE CONTRACTOR AND THE ENGINEER SHALL DRIVE THROUGH THE WORK SITE EACH NIGHT WHEN THE LIGHTING IS IN PLACE AND OPERATIVE PRIOR TO COMMENCING ANY WORK. IF GLARE IS DETECTED, THE LIGHT PLACEMENT AND SHIELDING SHALL BE ADJUSTED TO THE SATISFACTION OF THE ENGINEER BEFORE WORK PROCEEDS.

SIDEWALK CLOSED SIGNS.

THE CONTRACTOR SHALL ERECT AND MAINTAIN, "SIDEWALK CLOSED" AT ALL INTERSECTIONS WHILE WORK IS BEING PERFORMED. INTERSECTION CROSSINGS SHALL BE REOPENED UPON COMPLETION OF ADA RAMP. FOR FURTHER INFORMATION, SEE SCD MT-110.10.

PAYMENT FOR THE SIDEWALK CLOSED SIGNS SHALL INCLUDE ALL LABOR AND MATERIALS NECESSARY TO INSTALL AND MAINTAIN THE SIGNS, SHALL BE PAID FOR UNDER ITEM 614 -MAINTAINING TRAFFIC.

PAYMENT FOR ALL LABOR, EQUIPMENT AND MATERIALS SHALL BE INCLUDED IN THE LUMP SUM CONTRACT PRICE FOR ITEM 614 -MAINTAINING TRAFFIC.

DUST CONTROL.

THE CONTRACTOR SHALL FURNISH AND APPLY WATER FOR DUST CONTROL AS DIRECTED BY THE ENGINEER. THE FOLLOWING CONTINGENCY QUANTITY HAS BEEN INCLUDED FOR DUST CONTROL PURPOSES:

616, WATER 1 MGD

PHASE 1 - CURB RAMP CONSTRUCTION.

MAINTAIN ONE 11' LANE IN THE EASTBOUND DIRECTION USING THE EXISTING PAVEMENT AS SHOWN IN THE MOT PLANS.

BUSINESS ACCESS SHALL BE MAINTAINED AT ALL TIMES.

CONSTRUCT PROPOSED CURB RAMP ON THE SOUTH EAST CORNER OF THE MASON MONTGOMERY ROAD INTERSECTION, CONSTRUCT SHARED USE PATH TO THE END OF INTERSECTION RADIUS. RESTORE PAVEMENT. SEED AND MULCH EXPOSED SOIL.

WORK ZONE PAVEMENT MARKINGS AND MOT EQUIPMENT SHALL BE IN PLACE PRIOR TO OPENING THE LANES OF TRAFFIC.

PHASE 2 - MULTI-USE TRAIL CONSTRUCTION.

MAINTAIN ONE 11' LANE IN THE EASTBOUND DIRECTION USING THE EXISTING PAVEMENT AS SHOWN IN THE MOT PLANS.

BUSINESS ACCESS SHALL BE MAINTAINED AT ALL TIMES.

CONSTRUCT PROPOSED SHARED USE PATH, DECORATIVE RAILING, RETAINING WALLS, AND HEADWALLS. CONSTRUCT THE NEW SIDEWALK, SEED AND MULCH EXPOSED SOIL.

WORK ZONE PAVEMENT MARKINGS AND MOT EQUIPMENT SHALL BE IN PLACE PRIOR TO OPENING THE LANES OF TRAFFIC.

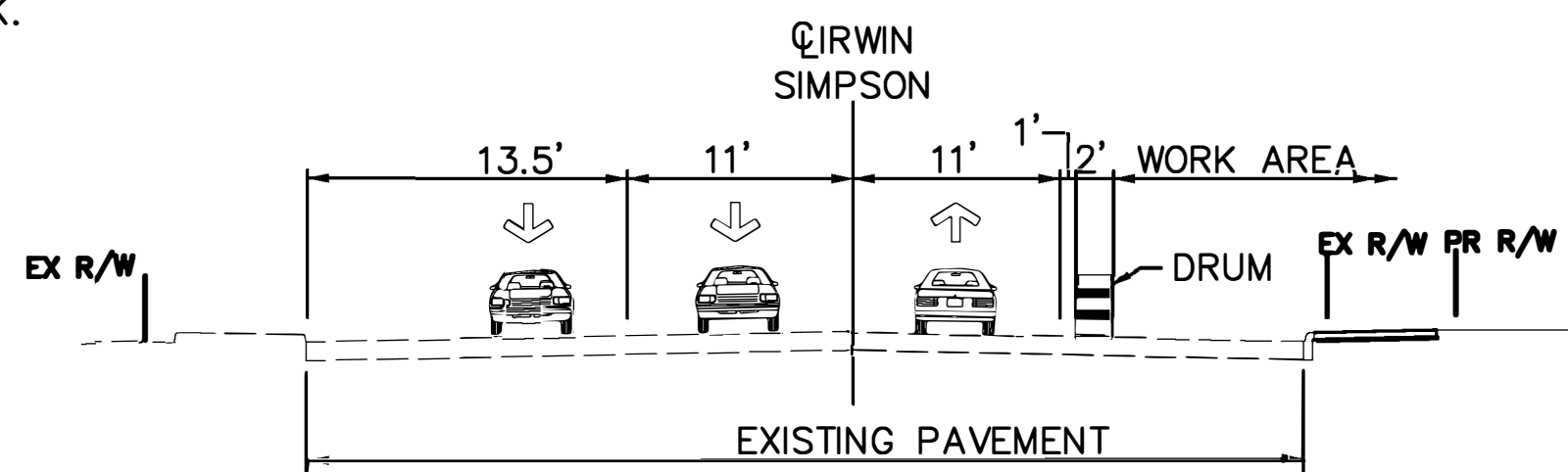

CURB/SIDEWALK CONSTRUCTION
NTS

PHASE 3 - PAVEMENT MARKING RESTORATION.

MAINTAIN ONE 11' LANE IN EACH DIRECTION USING CONES AND FLAGGERS. PROVIDE TURN LANES WHERE REQUIRED.

WITH TRAFFIC IN THIS PATTERN, PLACE THE PERMANENT PAVEMENT MARKINGS, NEW SIGNING AND ANY REMAINING CONSTRUCTION ITEMS.

ONCE ALL CONSTRUCTION ITEMS HAVE BEEN INSTALLED AND APPROVED BY THE ENGINEER, REMOVE ALL MOT EQUIPMENT ITEMS AND OPEN LANES TO THROUGH TRAFFIC.

"PCB" REFERS TO "PORTABLE CONCRETE BARRIER"
"OMUTCD" REFERS TO THE "OHIO MANUAL OF UNIFORM TRAFFIC CONTROL DEVICES", CURRENT EDITION.
"SCD" REFERS TO "STANDARD CONSTRUCTION DRAWING"
"CMS" REFERS TO "CONSTRUCTION AND MATERIAL SPECIFICATION" ODOT, CURRENT EDITION.
"MOT" REFERS TO "MAINTENANCE OF TRAFFIC"

CALCULATED
SCR
CHECKED
MM

MAINTENANCE OF TRAFFIC NOTES

HAM-27-11.09

F:\Projects\658800\05_Deliverables\Drawings\1.4603\Design\W01\Sheets\1.4603\MS001.dwg, 19-Sep-23, 3:58 PM

REF NO.	SHEET NO.	STATION TO STATION				614	614	614	614	614															
						WORK ZONE SIGN SUPPORT	WORK ZONE EDGE LINE CLASS I, 6", 740.06, TYPE I	WORK ZONE DOTTED LINE CLASS I, 8", 740.06, TYPE I	WORK ZONE ARROW, CLASS I	WORK ZONE WORD ON PAVEMENT, 72", CLASS I															
					EACH	MILE	FT	EACH	EACH																
CL IRWIN SIMPSON ROAD																									
MS-1	8	3+82.76	RT		1																				
WZEL-1	8	10+34.70	RT	TO 10+88.22		0.01																			
WZEL-2	8-11	10+57.15	RT	TO 38+00.00		0.52																			
WZDL-1	8	3+82.76	RT	TO 5+81.78			200.00																		
WZLA-1	8	5+81.78	RT					1																	
WZLA-2	8	6+61.78	RT					1																	
WZLA-3	8	7+41.78	RT					1																	
WZLA-4	8	8+21.78	RT					1																	
WZLA-5	9	9+01.78	RT					1																	
WZWP-1	8	6+21.78	RT						1																
WZWP-2	8	7+01.78	RT						1																
WZWP-3	8	7+81.78	RT						1																
WZWP-4	8	8+61.78	RT						1																
TOTALS CARRIED TO GENERAL SUMMARY					1	1	200	5	4																

F:\Projects\688800\05_Deliverables\Drawings\114603\Design\MOT\Sheets\114603MP000.dwg 19-Sep-23 3:38 PM

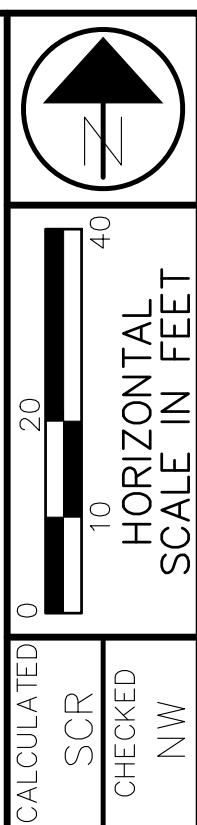
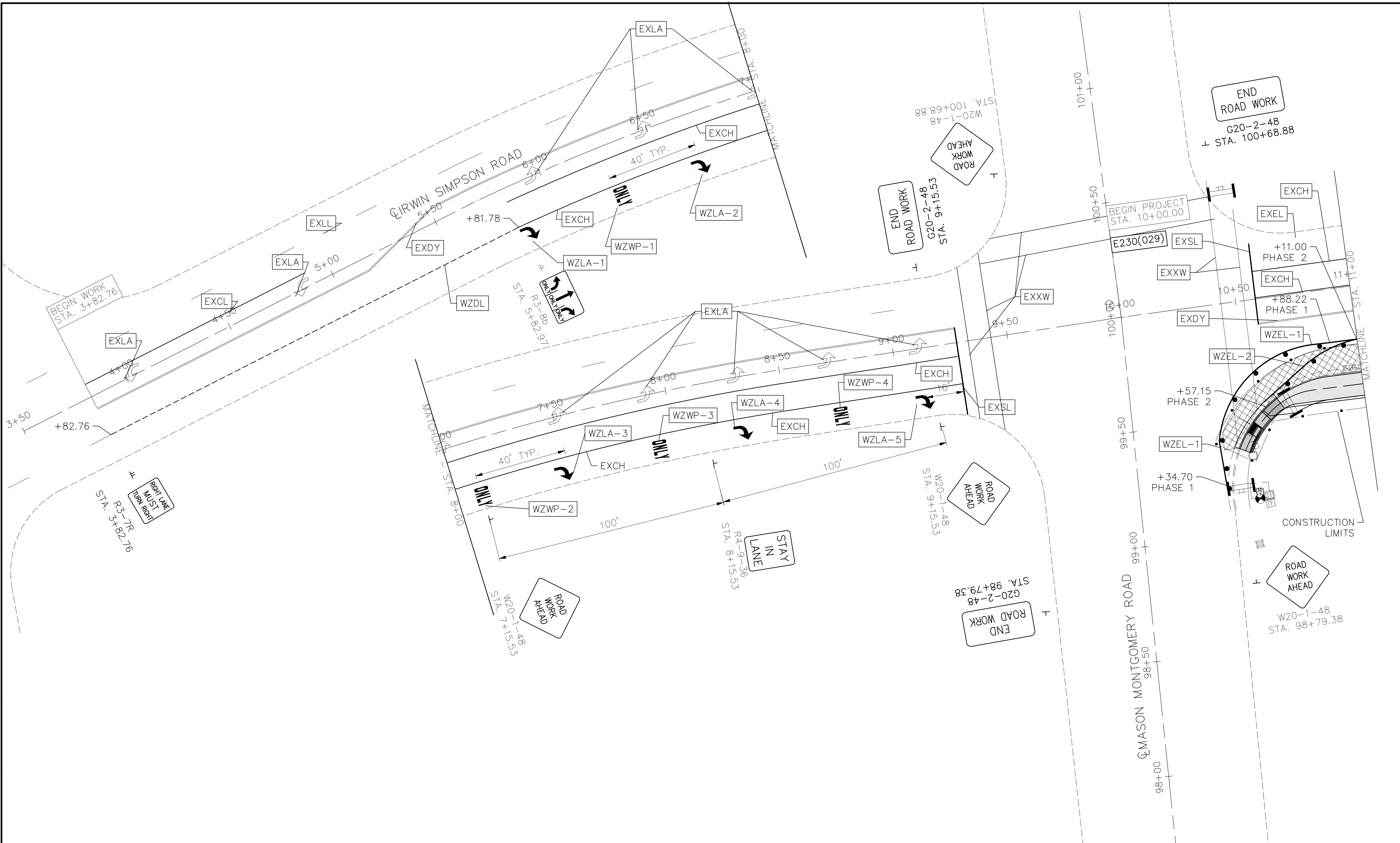

MAINTENANCE OF TRAFFIC PLAN
STA. 3+82.76 TO STA. 11+00.00

WAR-TR55-2.11

08
71

WORK ZONE PAVEMENT MARKING LEGEND			
EL	EDGE LINE, 6" WHITE	LL	LANE LINE, 6" WHITE
CH	CHANNELIZING LINE, 6" WHITE	SL	STOP LINE
DY	CENTER LINE, SOLID DOUBLE YELLOW	XW	CROSS WALK
DL	DOTTED LINE, 8" WHITE	LA	LANE ARROW
WP	WORD ON PAVEMENT		

(EX = EXISTING) (WZ = WORK ZONE)

SIGN LEGEND			
	WORK AREA		DIRECTION OF TRAFFIC
	DRUM		
	THREE BEAM BARRIER WITH SIDEWALK CLOSED SIGN		SIDEWALK CLOSED
	R9-9-36		

- WORK ZONE NOTES
1. PAVEMENT MARKINGS AND EDGE OF PAVEMENT ARE PROVIDED BY CAGIS DATA AND AERIAL PHOTOS.
 2. CONTRACTOR TO PLACE WORK ZONE ARROWS PER THE OHIO MANUAL OF UNIFORM TRAFFIC CONTROL DEVICES.
 3. THE EXISTING R3-8b SIGN AT STATION 5+82.97 SHALL BE COVERED WITH THE R3-9b SIGN SHOWN DURING THE DURATION OF CONSTRUCTION.
 4. PEDESTRIAN TRAFFIC CROSSING THE WESTBOUND LEG OF IRWIN SIMPSON SHALL ONLY BE RESTRICTED WHILE WORK IS ACTIVELY BEING PERFORMED ON THE CURB RAMP.

F:\Projects\688800\05_Deliverables\Drawings\114603\Design\MOT_Sheets\114603MP000.dwg 19-Sep-23 3:38 PM

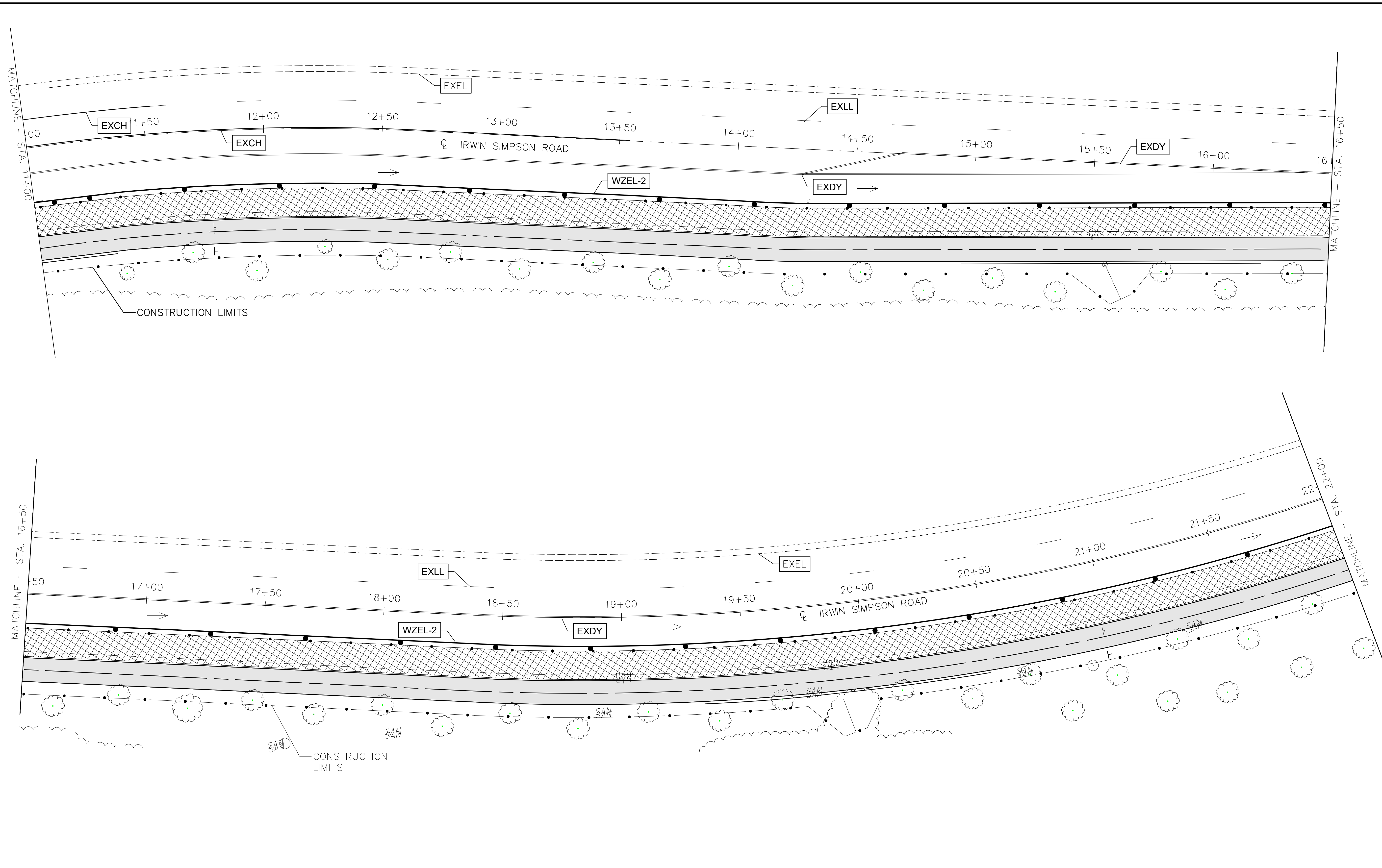

CALCULATED
SCR
CHECKED
NW

0 10 20
HORIZONTAL
SCALE IN FEET

MAINTENANCE OF TRAFFIC PLAN
STA. 11+00.00 TO STA. 22+00.00

WORK ZONE PAVEMENT MARKING LEGEND

EL	EDGE LINE, 6" WHITE	LL	LANE LINE, 6" WHITE
CH	CHANNELIZING LINE, 6" WHITE	SL	STOP LINE
DY	CENTER LINE, SOLID DOUBLE YELLOW	XW	CROSS WALK
DL	DOTTED LINE, 8" WHITE	LA	LANE ARROW
WP	WORD ON PAVEMENT		

(EX = EXISTING) (WZ = WORK ZONE)

SIGN LEGEND

	WORK AREA		DIRECTION OF TRAFFIC		DRUM
	THREE BEAM BARRIER WITH SIDEWALK CLOSED SIGN		SIDEWALK CLOSED		

R9-9-36

WORK ZONE NOTES

- PAVEMENT MARKINGS AND NORTH EDGE OF PAVEMENT ARE PROVIDED BY CAGIS DATA AND AERIAL PHOTOS.

F:\Projects\688800\05_Deliverables\Drawings\114603\Design\MOT_Sheets\114603MP000.dwg 19-Sep-23 3:38 PM

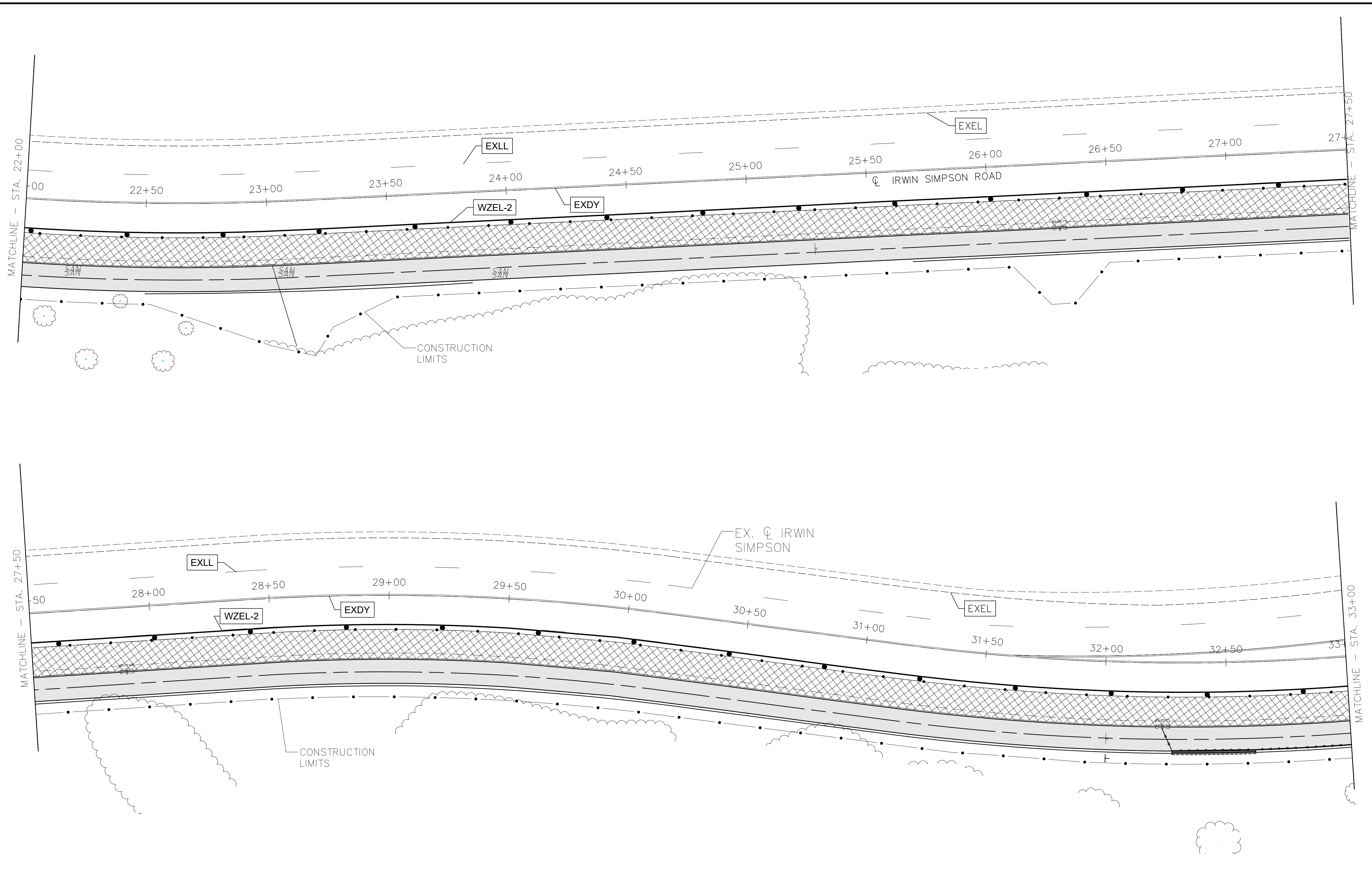

WORK ZONE PAVEMENT MARKING LEGEND			
EL	EDGE LINE, 6" WHITE	LL	LANE LINE, 6" WHITE
CH	CHANNELIZING LINE, 6" WHITE	SL	STOP LINE
DY	CENTER LINE, SOLID DOUBLE YELLOW	XW	CROSS WALK
DL	DOTTED LINE, 8" WHITE	LA	LANE ARROW
WP	WORD ON PAVEMENT		

(EX = EXISTING) (WZ = WORK ZONE)

SIGN LEGEND			
	WORK AREA		DIRECTION OF TRAFFIC
	DRUM		
	THREE BEAM BARRIER WITH SIDEWALK CLOSED SIGN		SIDEWALK CLOSED
			R9-9-36

WORK ZONE NOTES

- PAVEMENT MARKINGS AND NORTH EDGE OF PAVEMENT ARE PROVIDED BY CAGIS DATA AND AERIAL PHOTOS.

CALCULATED

SCR

CHECKED

NW

0

20

40

10

HORIZONTAL

SCALE IN FEET

MAINTENANCE OF TRAFFIC PLAN

STA. 22+00.00 TO STA. 33+00.00

WAR-TR55-2.11

10

71

F:\Projects\688800\05_Deliverables\Drawings\114603\Design\MOT\Sheets\114603MP000.dwg 19-Sep-23 3:39 PM

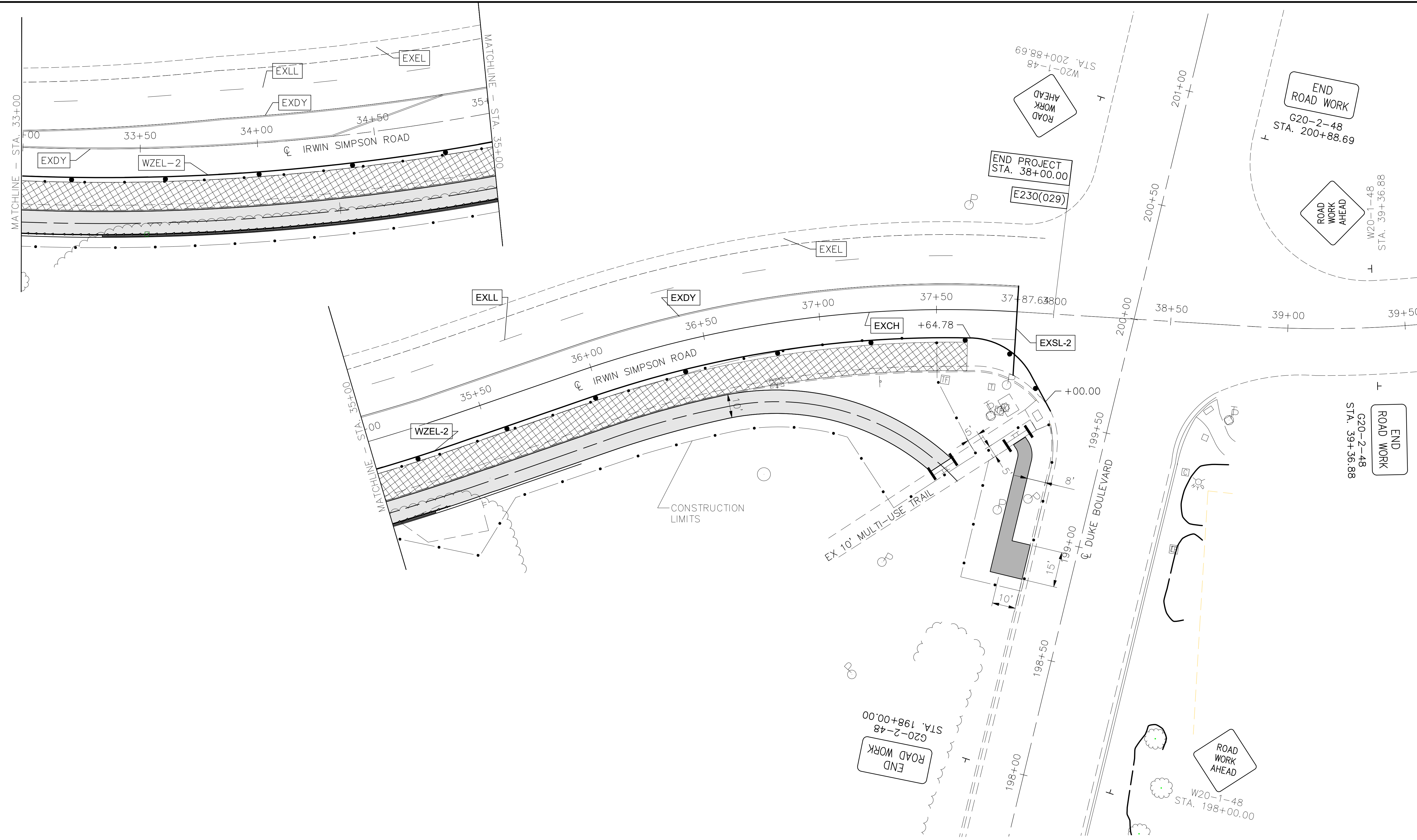

WORK ZONE PAVEMENT MARKING LEGEND

EL	EDGE LINE, 6" WHITE	LL	LANE LINE, 6" WHITE
CH	CHANNELIZING LINE, 6" WHITE	SL	STOP LINE
DY	CENTER LINE, SOLID DOUBLE YELLOW	XW	CROSS WALK
DL	DOTTED LINE, 8" WHITE	LA	LANE ARROW
WP	WORD ON PAVEMENT		

(EX = EXISTING) (WZ = WORK ZONE)

SIGN LEGEND

	WORK AREA		DIRECTION OF TRAFFIC		DRUM
	THRIE BEAM BARRIER WITH SIDEWALK CLOSED SIGN		SIDEWALK CLOSED		

R9-9-36

WORK ZONE NOTES

1. PAVEMENT MARKINGS AND NORTH EDGE OF PAVEMENT ARE PROVIDED BY CAGIS DATA AND AERIAL PHOTOS.
2. A 5 FOOT WIDE PEDESTRIAN PATH SHALL BE MAINTAINED ALONG THE EXISTING MULTI-USE PATH AT ALL TIMES DURING CONSTRUCTION.
3. CONSTRUCTION OF THE SIDEWALK AND BUS PAD SHALL NOT INTERFERE WITH TRAFFIC ALONG DUKE BLVD.
4. SIDEWALK CLOSED SIGNS TO BE ERECTED UPON INSTALLATION OF ADJACENT TRAIL OR SIDEWALK UNTIL CONSTRUCTION IS COMPLETE.
5. CONFLICTING LANE USE SIGNS AFFECTED BY CONSTRUCTION SHALL BE COVERED UNTIL MOT HAS BEEN REMOVED.

WAR-TR55-2.11

MAINTENANCE OF TRAFFIC PLAN
STA. 33+00.00 TO STA. 39+50.00

11
71

CALCULATED SCR NW
CHECKED NW

0 10 20
HORIZONTAL SCALE IN FEET

F:\Projects\688800\05_Deliverables\Drawings\114603\Design\Roadway\Sheets\114603GG001.dwg 19-Sep-23 3:39 PM

SHEET NUM.											PART.	ITEM	ITEM	GRAND	UNIT	DESCRIPTION	SEE SHEET NO.
4	5	6	7	14	15	38	43	48	50		01/MPO/28	EXT	TOTAL				
			1								1	614	12440	1	EACH	MAINTENANCE OF TRAFFIC WORK ZONE SIGN SUPPORT	
			1								1	614	22210	1	MILE	WORK ZONE EDGE LINE, CLASS I, 6", 740.06, TYPE I	
			200								200	614	24404	200	FT	WORK ZONE DOTTED LINE, CLASS I, 8", 740.06, TYPE I	
			5								5	614	30000	5	EACH	WORK ZONE ARROW, CLASS I	
			4								4	614	31000	4	EACH	WORK ZONE WORD ON PAVEMENT, 72", CLASS I	
																INCIDENTALS	
											LS	614	11000	LS		MAINTAINING TRAFFIC	
											LS	623	10000	LS		CONSTRUCTION LAYOUT STAKES AND SURVEYING	
											LS	624	10000	LS		MOBILIZATION	

GENERAL SUMMARY

WAR - TR55 - 2.11

CALCULATED
SCR
CHECKED
MAM

REF NO.	SHEET NO.	STATION TO STATION				202	511	611	611	611	611	611	611											
						HEADWALL REMOVED, AS PER PLAN	CLASS QC1 CONCRETE WITH QC/QA, HEADWALL, AS PER PLAN	12" CONDUIT, TYPE A, 706.04	15" CONDUIT, TYPE A, 706.04	22" X 34" CONDUIT, TYPE A, 706.04	29" X 45" CONDUIT, TYPE A, 706.04	MANHOLE ADJUSTED TO GRADE	MANHOLE, NO. 3											
					EACH	CY	FT	FT	FT	FT	EACH	EACH												
CL SHARED USE PATH																								
R1	18	60+55.02	RT								1													
R2	18	63+93.67	RT								1													
R3	21	75+23.81	RT								1													
CL IRWIN SIMPSON ROAD																								
D1	17	15+34.42			1	0.25		9.00				1												
D2	17	19+78.73			1	0.20	8.00																	
D3	18	22+94.52			1	0.49			16.00															
D4	19	26+29.40			1	0.20	8.00																	
D5	21	35+68.63			1				10.00															
TOTALS CARRIED TO GENERAL SUMMARY					5	2	16	9	10	16	3	1												

SUBSUMMARY	CALCULATED
	SCR
	CHECKED
WAR - TR55 - 2.11	MAM

STATION RANGE			TYPICAL SECTION	SIDE	DISTANCE (D)	AVERAGE WIDTH (W)	SURFACE AREA (A) A=DxW/9	CADD GENERATED AREA	202	202	204	209	301	304	407	441	607	608	609											
									WALK REMOVED	CURB REMOVED	SUBGRADE COMPACTION	LINEAR GRADING, AS PER PLAN	ASPHALT CONCRETE BASE, PG64-22	AGGREGATE BASE	TACK COAT	ASPHALT CONCRETE SURFACE COURSE, TYPE 1, (448), PG64-22	FENCE, MISC.:RAILING	5" CONCRETE WALK	CURB, TYPE 6											
CL SHARED USE PATH					FT	FT	SY	SY	SF	FT	SY	MILE	CY	CY	GAL	CY	FT	SF	FT											
50+00.00	TO	50+12.20	B	CL	12.20	6.00	8.13	6.78	8.13	30.40	6.78			1.13																
50+12.20	TO	50+25.98	C/D/E	CL	13.78	6.00	9.19	7.78		13.78	7.78			1.30																
50+25.98	TO	50+47.42	I	CL	21.44	8.00	19.06	18.24			18.24	0.01	2.01	3.04	1.09	0.79														
50+47.42	TO	71+96.36		CL	2148.94	10.00	2387.71	2387.71			2387.71	0.41	262.65	397.95	143.26	103.47														
71+96.36	TO	72+31.15	F	CL	34.79	10.00	38.66	38.66			38.66		4.25	6.44	2.32	1.68														
72+31.15	TO	73+06.36		CL	75.21	10.00	83.57	83.57			83.57	0.02	9.19	13.93	5.01	3.62														
73+06.36	TO	74+97.36	F	CL	191.00	10.00	212.22	212.22			212.22		23.34	35.37	12.73	9.20														
74+97.36	TO	75+04.43	G		7.07	10.00	7.86	7.86			7.86		0.86	1.31	0.47	0.34														
75+04.43	TO	75+62.55		CL	58.12	10.00	64.58	64.58			64.58	0.04	7.10	10.76	3.87	2.80														
75+62.55	TO	77+27.35	H	CL	164.80	10.00	183.11	183.11			183.11	0.08	20.14	30.52	10.99	7.93														
50+00.00	TO	50+95.41		RT	95.41												95.41													
54+51.31	TO	55+77.37		RT	126.06												126.06													
58+92.00	TO	60+12.28		RT	120.28												120.28													
62+18.93	TO	63+55.12		RT	136.19												136.19													
65+38.73	TO	75+62.55		RT	1023.82												1023.82													
CL DUKE BLVD																														
198+80.90	TO	198+95.90		LT	15.00	14.00	23.33	23.33			23.33			7.70																
198+95.90	TO	199+40.18		LT	44.28	6.00	29.52	29.52			29.52			9.74																
SUBTOTALS									8.13	44.18	3063.35	0.56	329.55	519.19	179.76	129.82	1501.76	475.68	25.98											
TOTALS CARRIED TO GENERAL SUMMARY									9	45	3064	1	330	520	180	130	1502	476	26											

F:\Projects\688800\05_Deliverables\Drawings\114603\Design\Roadway\Sheets\114603GP000.dwg, 19-Sep-23, 3:40 PM

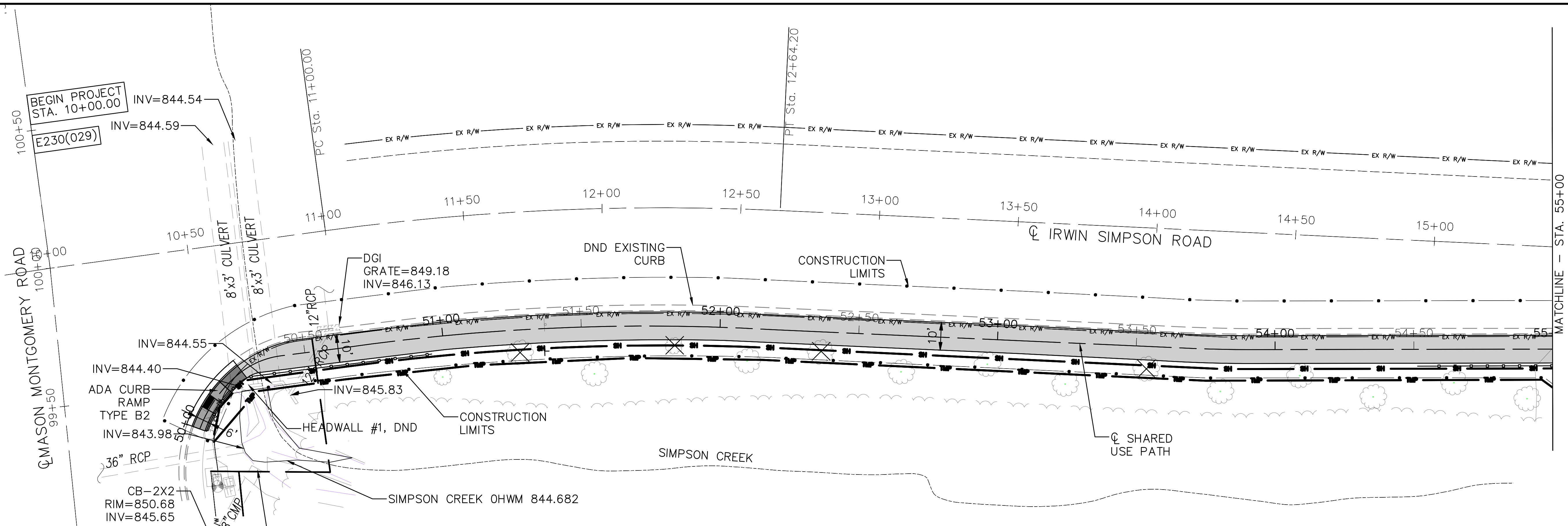

- LINETYPE LEGEND**
- Ex SH — EX. STANDARD HIGHWAY EASEMENT
 - SH — STANDARD HIGHWAY EASEMENT
 - Ex R/W — EX. RIGHT OF WAY
 - TMP — TEMPORARY EASEMENT
 - — CENTERLINE RIGHT OF WAY
 - SAN — EX. SANITARY STORM LINE
 - — EX. STORM SEWER LINE
 - — CONSTRUCTION LIMITS
 - PROP. RAILING

- LEGEND**
- ▨ PROP. MULTI-USE TRAIL
 - ▨ PROP. SIDEWALK
 - ▨ PROP. CURB RAMP
 - ▨ PROP. RETAINING WALL

- NOTES**
1. FOR TYPICAL SECTION SEE SHEET 03
 2. FOR INTERSECTION DETAILS SEE SHEET 36
 3. FOR REINFORCED PAVEMENT SEE SHEETS 48 TO 49
 4. FOR RETAINING WALL DETAILS SEE SHEETS 50 TO 54
 5. FOR DETAIL GRADING SEE SHEET 37
 6. FOR HEADWALL DETAILS SEE SHEET 38 TO 42

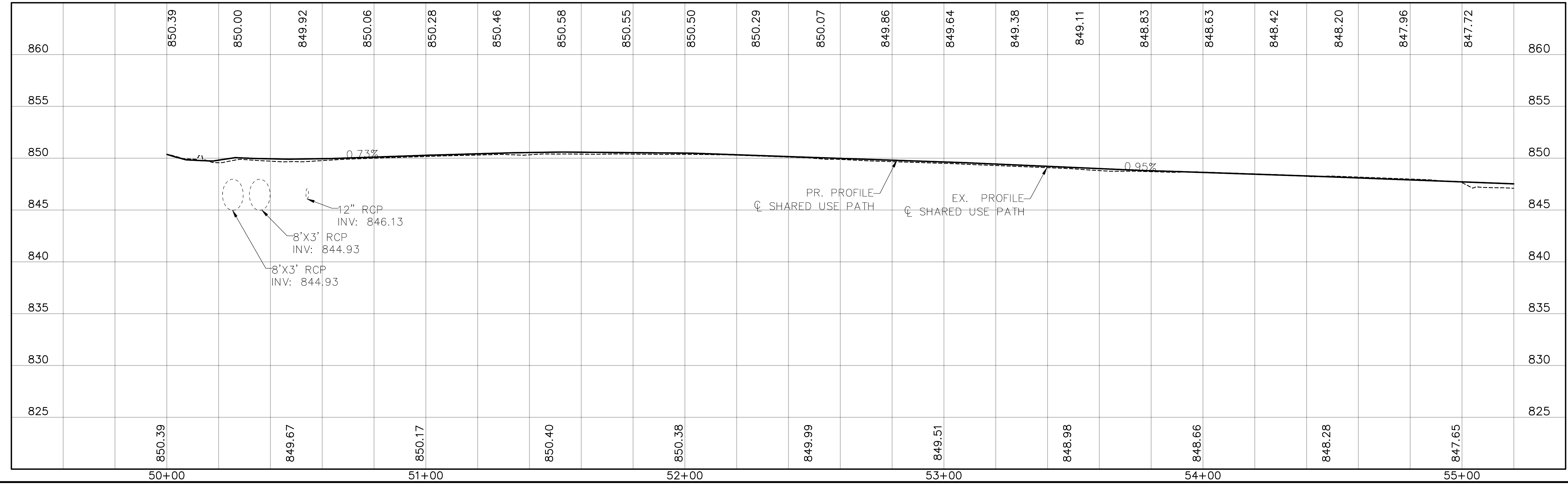

PLAN AND PROFILE

STA. 50+00 TO STA. 55+00

WAR-TR55-2.11

CALCULATED

SCR

CHECKED

NW

HORIZONTAL SCALE IN FEET

1" = 40'

16

71



0 10 20
HORIZONTAL
SCALE IN FEET

CALCULATED
SCR
CHECKED
NW

PLAN AND PROFILE
STA. 55+00 TO STA. 60+00

WAR-TR55-2.11

17
71

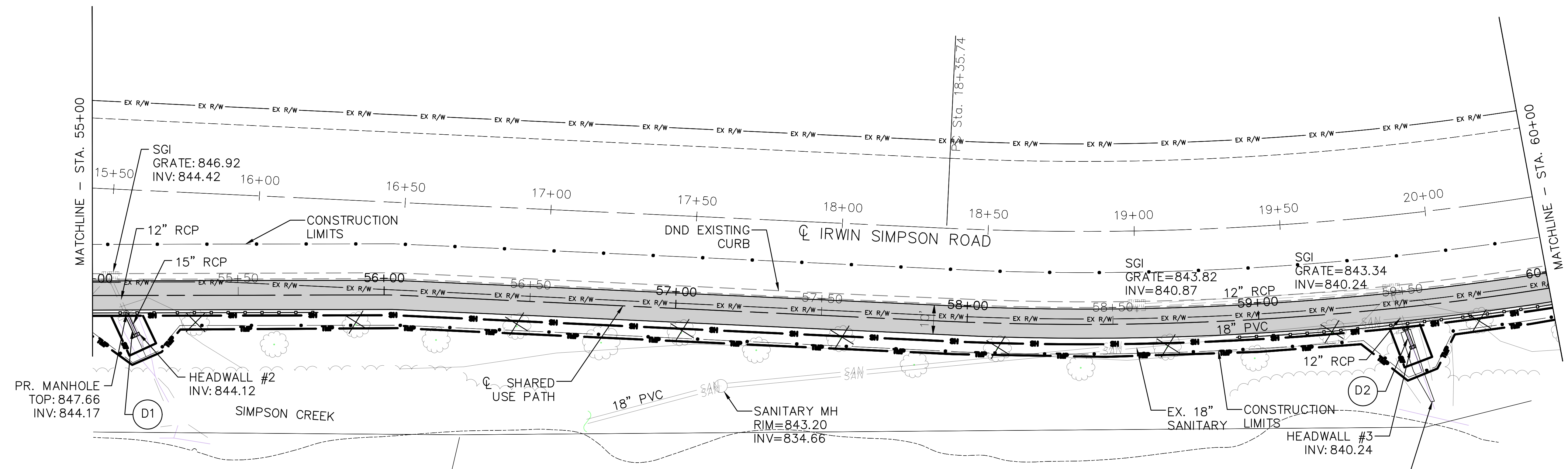

- LINETYPE LEGEND**
- Ex SH — EX. STANDARD HIGHWAY EASEMENT
 - SH — STANDARD HIGHWAY EASEMENT
 - Ex R/W — EX. RIGHT OF WAY
 - TMP — TEMPORARY EASEMENT
 - — CENTERLINE RIGHT OF WAY
 - SAN — EX. SANITARY STORM LINE
 - — EX. STORM SEWER LINE
 - — CONSTRUCTION LIMITS
 - — PROP. RAILING

- LEGEND**
- ▨ PROP. MULTI-USE TRAIL
 - ▨ PROP. SIDEWALK
 - ▨ PROP. CURB RAMP
 - ▨ PROP. RETAINING WALL

- NOTES**
1. FOR TYPICAL SECTION SEE SHEET 03
 2. FOR INTERSECTION DETAILS SEE SHEET 36
 3. FOR RETAINING WALL DETAILS SEE SHEETS 50 TO 54
 4. FOR DETAIL GRADING SEE SHEET 37
 5. FOR HEADWALL DETAILS SEE SHEET 38 TO 42

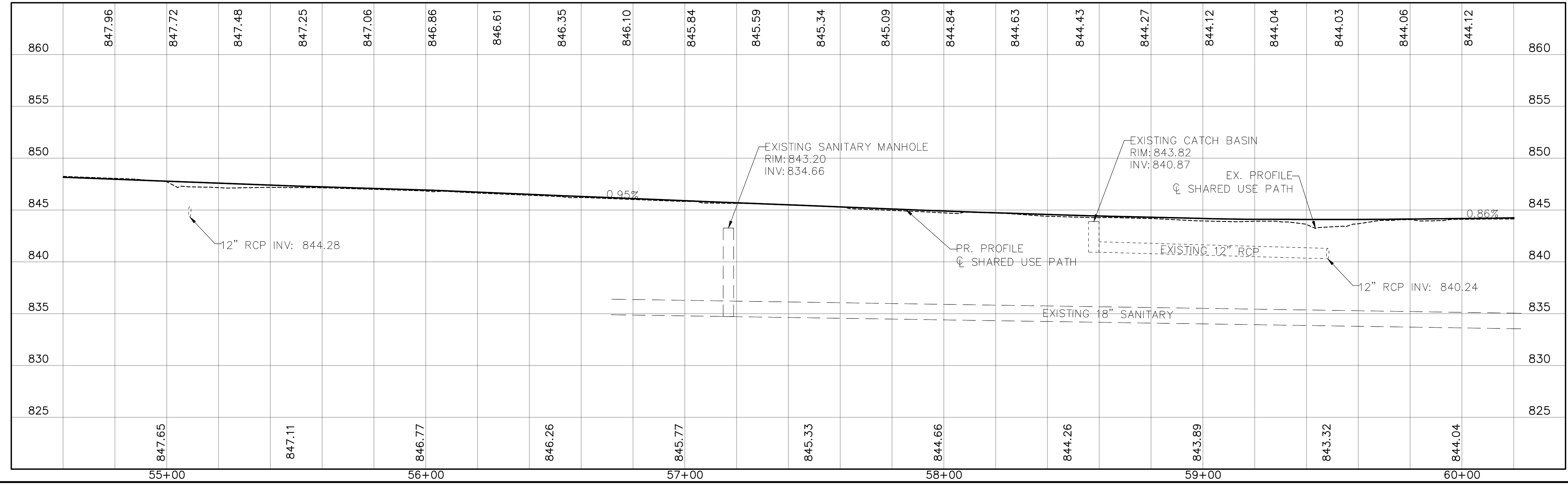

F:\Projects\688800\05_Deliverables\Drawings\114603\Design\Roadway\Sheets\114603CP00.dwg 19-Sep-23 3:40 PM

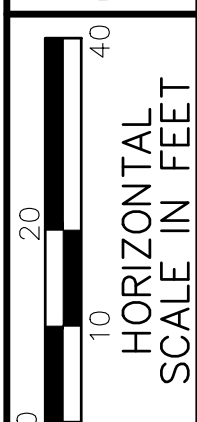

CALCULATED 0
SCR
CHECKED NW

PLAN AND PROFILE
60+00 TO 65+00

WAR-TR55-2.11

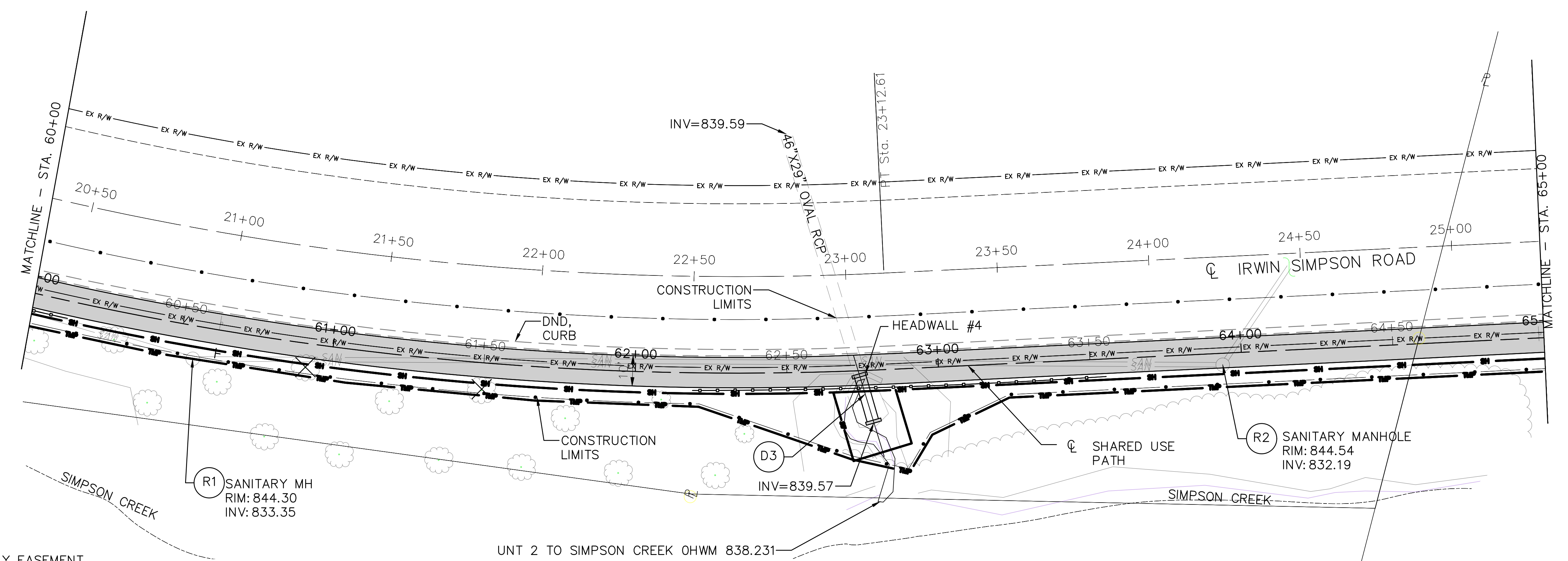

- LINETYPE LEGEND**
- Ex SH — EX. STANDARD HIGHWAY EASEMENT
 - SH — STANDARD HIGHWAY EASEMENT
 - Ex R/W — EX. RIGHT OF WAY
 - TMP — TEMPORARY EASEMENT
 - — CENTERLINE RIGHT OF WAY
 - SAN — EX. SANITARY STORM LINE
 - — EX. STORM SEWER LINE
 - — CONSTRUCTION LIMITS
 - — PROP. RAILING

- LEGEND**
- ▨ PROP. MULTI-USE TRAIL
 - ▨ PROP. SIDEWALK
 - ▨ PROP. CURB RAMP
 - ▨ PROP. RETAINING WALL

- NOTES**
1. FOR TYPICAL SECTION SEE SHEET 03
 2. FOR INTERSECTION DETAILS SEE SHEET 36
 3. FOR RETAINING WALL DETAILS SEE SHEETS 50 TO 54
 4. FOR DETAIL GRADING SEE SHEET 37
 5. FOR HEADWALL DETAILS SEE SHEET 38 TO 42

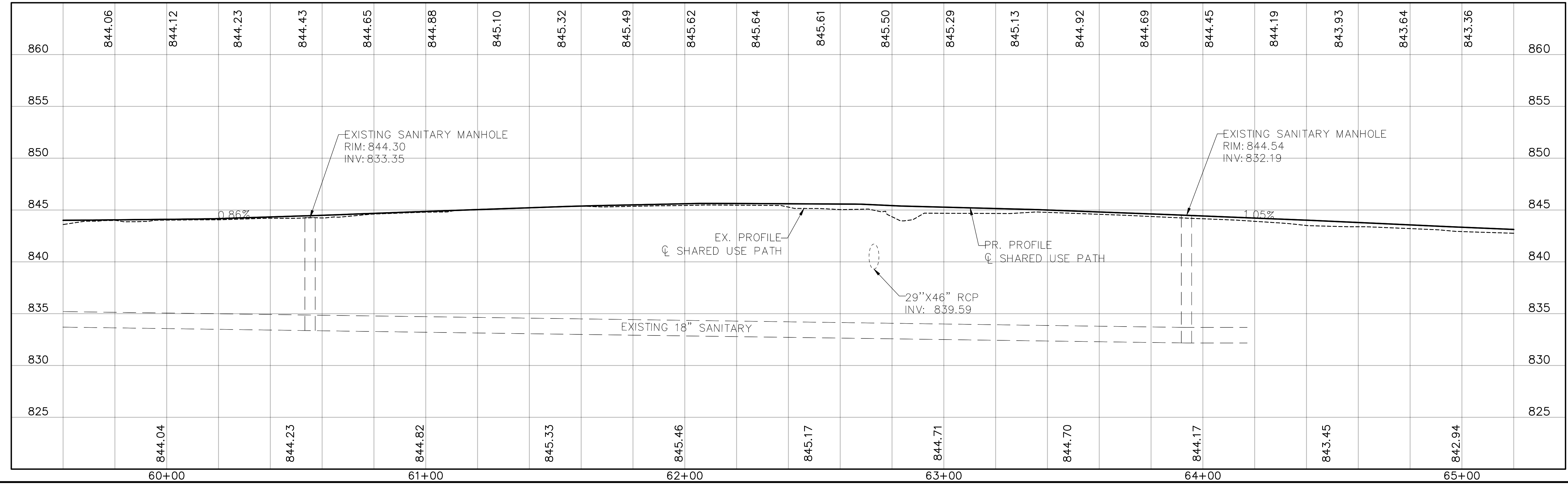

F:\Projects\688800\05_Deliverables\Drawings\114603\Design\Roadway\Sheets\114603GF00.dwg 19-Sep-23 3:40 PM

F:\Projects\688800\05_Deliverables\Drawings\Roadway\Sheets\114603\00.dwg, 19-Sep-23, 3:41 PM

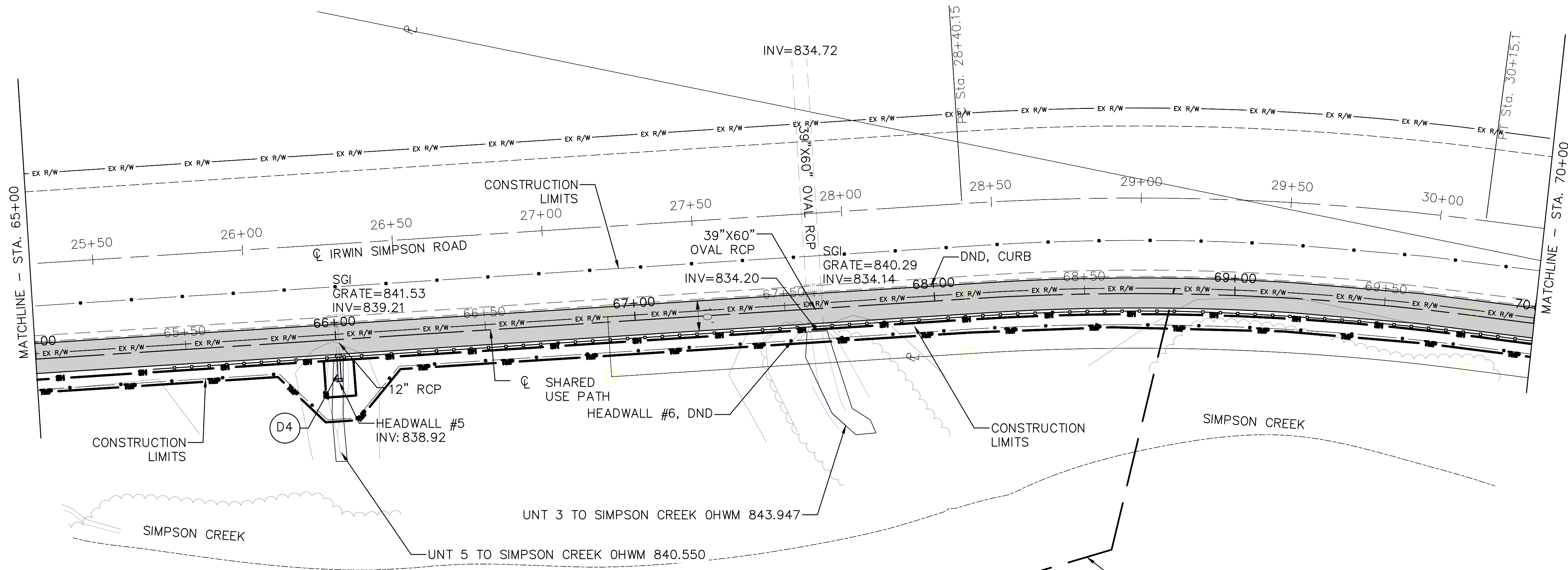

- LINETYPE LEGEND**
- Ex SH — EX. STANDARD HIGHWAY EASEMENT
 - SH — STANDARD HIGHWAY EASEMENT
 - Ex R/W — EX. RIGHT OF WAY
 - TMP — TEMPORARY EASEMENT
 - — CENTERLINE RIGHT OF WAY
 - SAN — EX. SANITARY STORM LINE
 - — EX. STORM SEWER LINE
 - - - CONSTRUCTION LIMITS
 - ○ ○ ○ ○ PROP. RAILING

- LEGEND**
- ▨ PROP. MULTI-USE TRAIL
 - ▨ PROP. SIDEWALK
 - ▨ PROP. CURB RAMP
 - ▨ PROP. RETAINING WALL

NOTES

1. FOR TYPICAL SECTION SEE SHEET 03
2. FOR INTERSECTION DETAILS SEE SHEET 36
3. FOR RETAINING WALL DETAILS SEE SHEETS 50 TO 54
4. FOR DETAIL GRADING SEE SHEET 37
5. FOR HEADWALL DETAILS SEE SHEET 38 TO 42

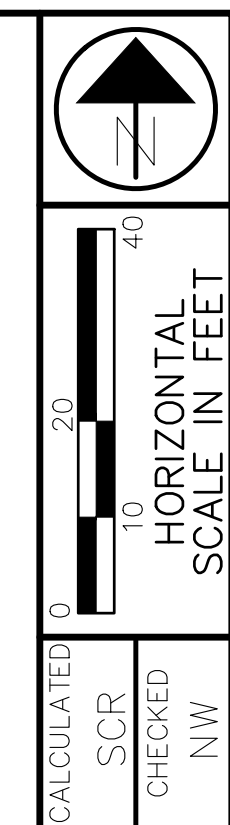
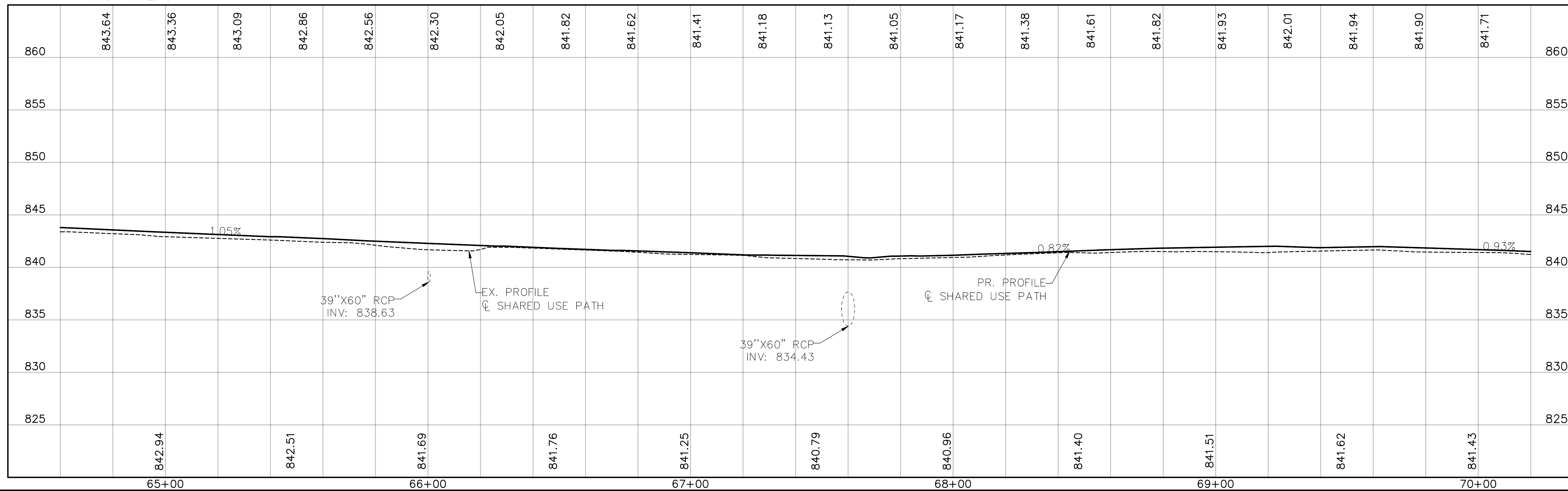

PLAN AND PROFILE
STA. 65+00 TO 70+00

WAR-TR55-2.11



0 10 20 30 40
HORIZONTAL
SCALE IN FEET

CALCULATED
SCR
CHECKED
NW

PLAN AND PROFILE
70+00 TO 75+00

WAR-TR55-2.11

20
71

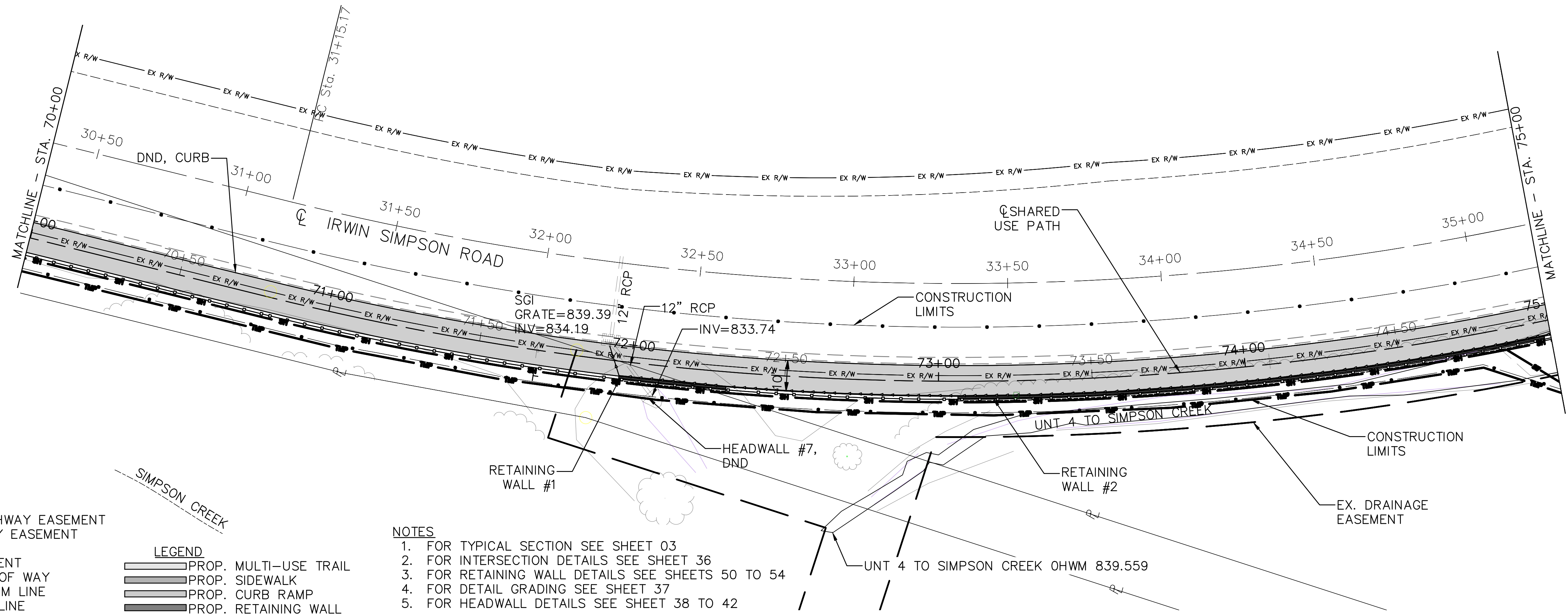

LINETYPE LEGEND

— Ex SH	EX. STANDARD HIGHWAY EASEMENT
— SH	STANDARD HIGHWAY EASEMENT
— Ex R/W	EX. RIGHT OF WAY
— TMP	TEMPORARY EASEMENT
—	CENTERLINE RIGHT OF WAY
— SAN	EX. SANITARY STORM LINE
—	EX. STORM SEWER LINE
—	CONSTRUCTION LIMITS
—	PROP. RAILING

LEGEND

[Pattern]	PROP. MULTI-USE TRAIL
[Pattern]	PROP. SIDEWALK
[Pattern]	PROP. CURB RAMP
[Pattern]	PROP. RETAINING WALL

- NOTES**
1. FOR TYPICAL SECTION SEE SHEET 03
 2. FOR INTERSECTION DETAILS SEE SHEET 36
 3. FOR RETAINING WALL DETAILS SEE SHEETS 50 TO 54
 4. FOR DETAIL GRADING SEE SHEET 37
 5. FOR HEADWALL DETAILS SEE SHEET 38 TO 42

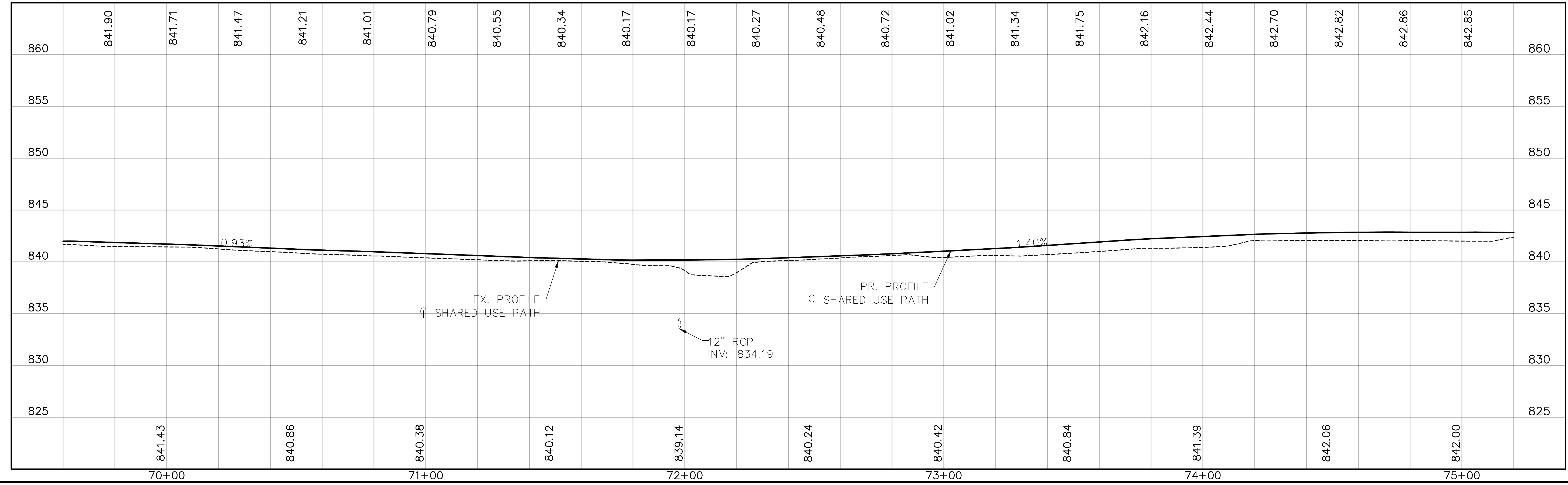

F:\Projects\688800\05_Deliverables\Drawings\114603\Design\Roadway\Sheets\114603GF000.dwg 19-Sep-23 3:41 PM

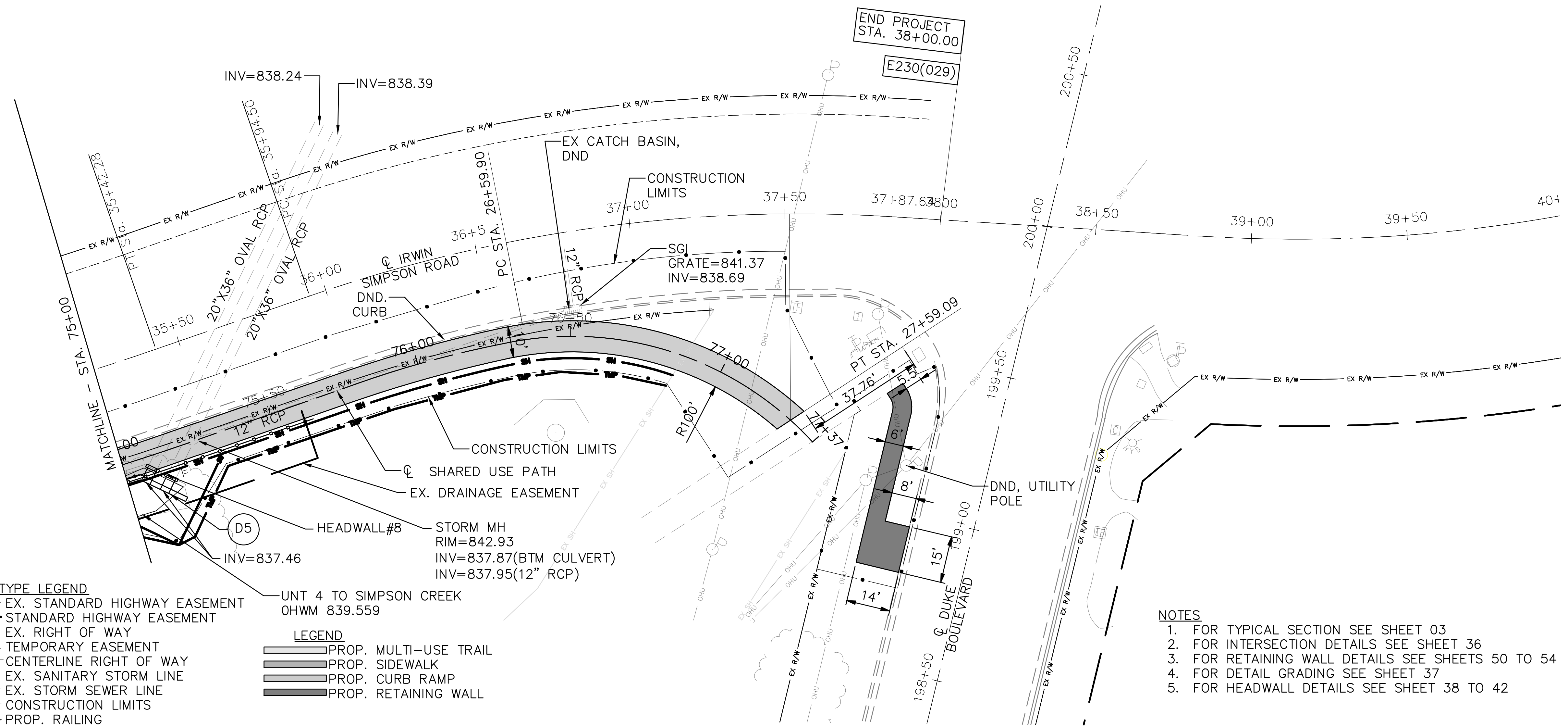

- LINETYPE LEGEND**
- Ex SH — EX. STANDARD HIGHWAY EASEMENT
 - SH — STANDARD HIGHWAY EASEMENT
 - Ex R/W — EX. RIGHT OF WAY
 - TMP — TEMPORARY EASEMENT
 - — CENTERLINE RIGHT OF WAY
 - SAN — EX. SANITARY STORM LINE
 - — EX. STORM SEWER LINE
 - — CONSTRUCTION LIMITS
 - — PROP. RAILING

- LEGEND**
- ▨ PROP. MULTI-USE TRAIL
 - ▨ PROP. SIDEWALK
 - ▨ PROP. CURB RAMP
 - ▨ PROP. RETAINING WALL

- NOTES**
1. FOR TYPICAL SECTION SEE SHEET 03
 2. FOR INTERSECTION DETAILS SEE SHEET 36
 3. FOR RETAINING WALL DETAILS SEE SHEETS 50 TO 54
 4. FOR DETAIL GRADING SEE SHEET 37
 5. FOR HEADWALL DETAILS SEE SHEET 38 TO 42

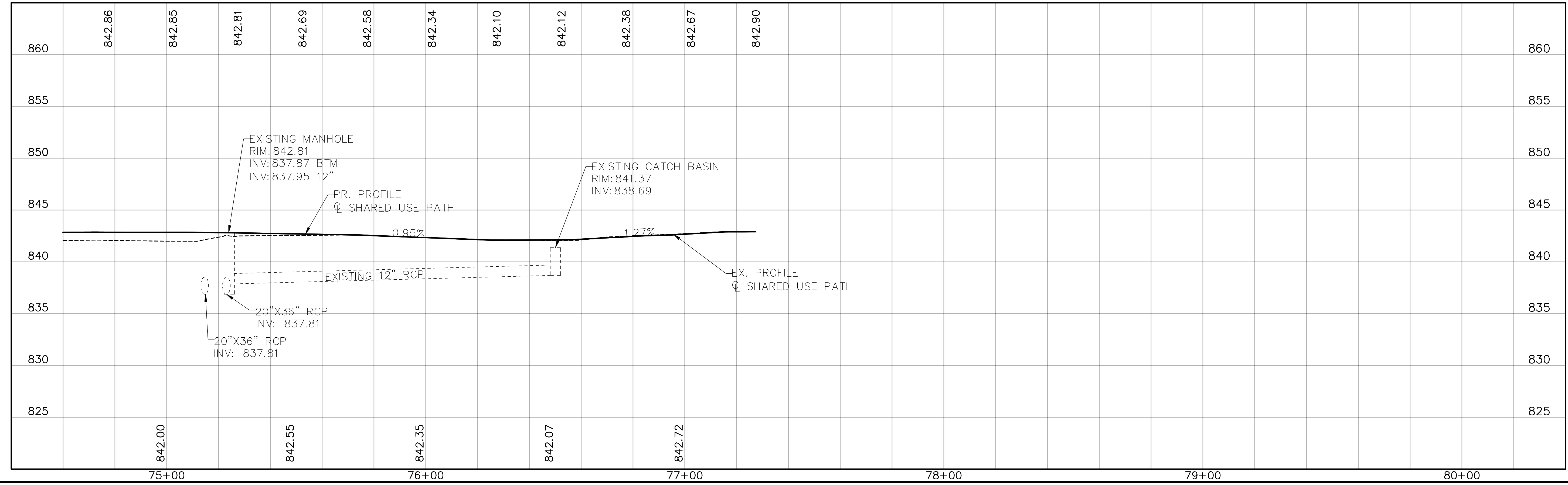

SEEDING	END SQ.	
	WIDTH	YDS.
15	60	41

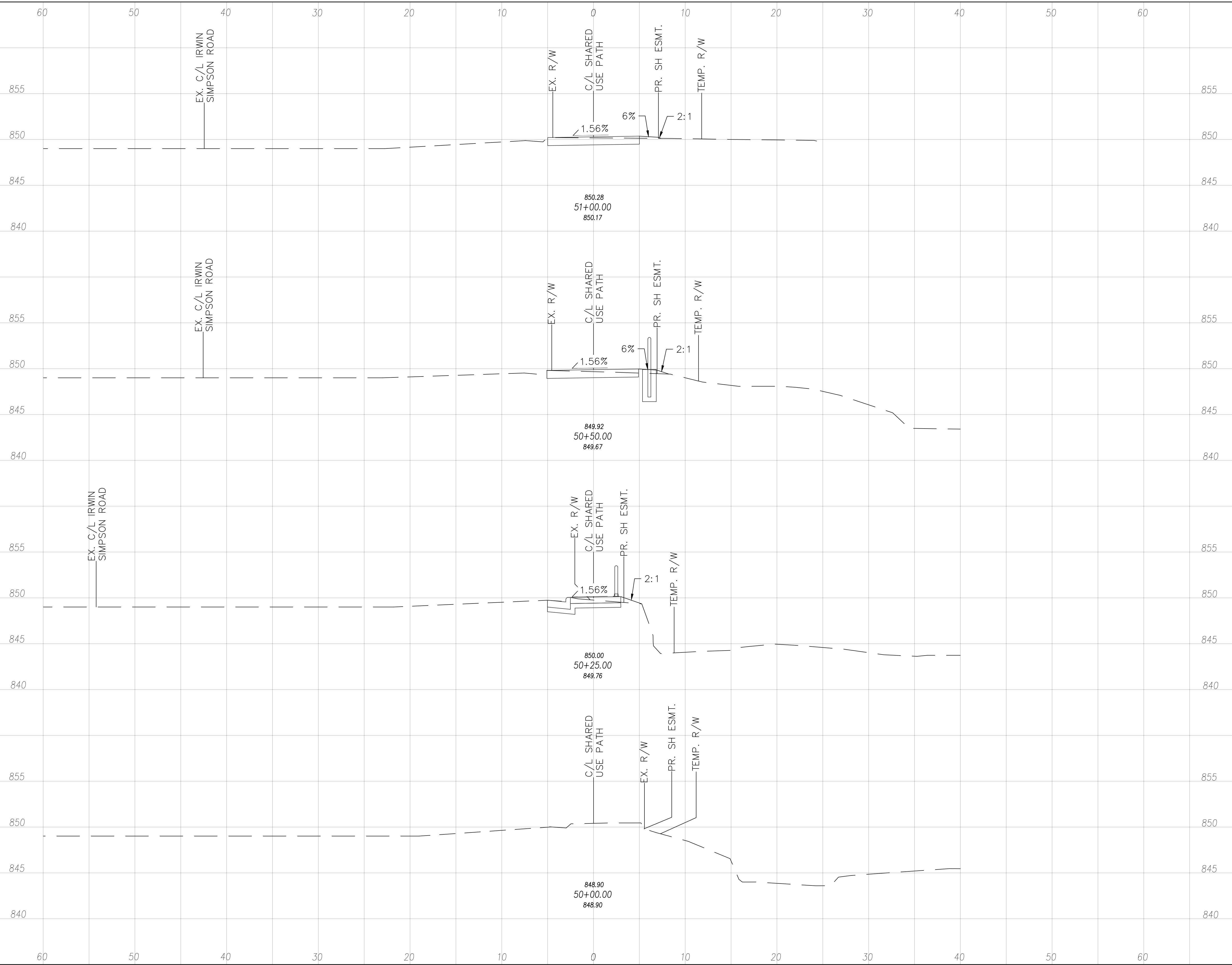

END CUT	AREA FILL	VOLUME	
		CUT	FILL
8	0	13	1
7	1	13	1
5	1	11	2
0	0	5	1
5	1	42	5

CROSS SECTIONS
50+00.00 TO 51+00.00

WAR-TR55-2.11

22
71

SEEDING	
END WIDTH	SQ. YDS.
3	57
3	16
2	13
2	13
3	15
3	16

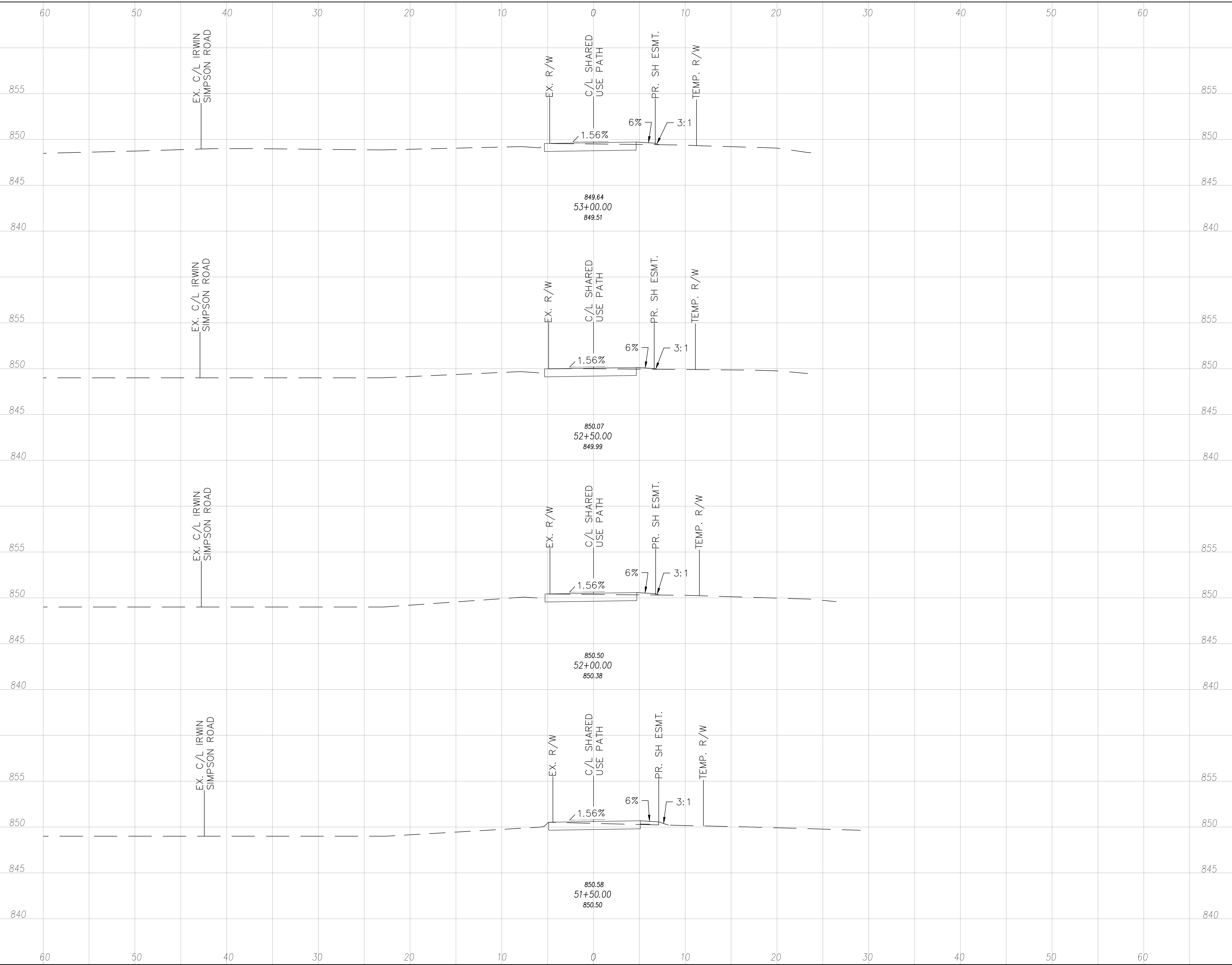

END AREA		VOLUME	
CUT	FILL	CUT	FILL
7	0	54	4
7	0	13	1
8	0	14	1
8	0	14	1
7	1	13	1

CROSS SECTIONS
 51+50.00 TO 53+00.00

WAR-TR55-2.11

23
71

STATION	SEEDING	
	END WIDTH	SQ. YDS.
18	18	18
4	4	4
11	11	11
0	0	0
2	2	2
0	0	0
9	9	9
4	4	4
2	2	2
41	41	41

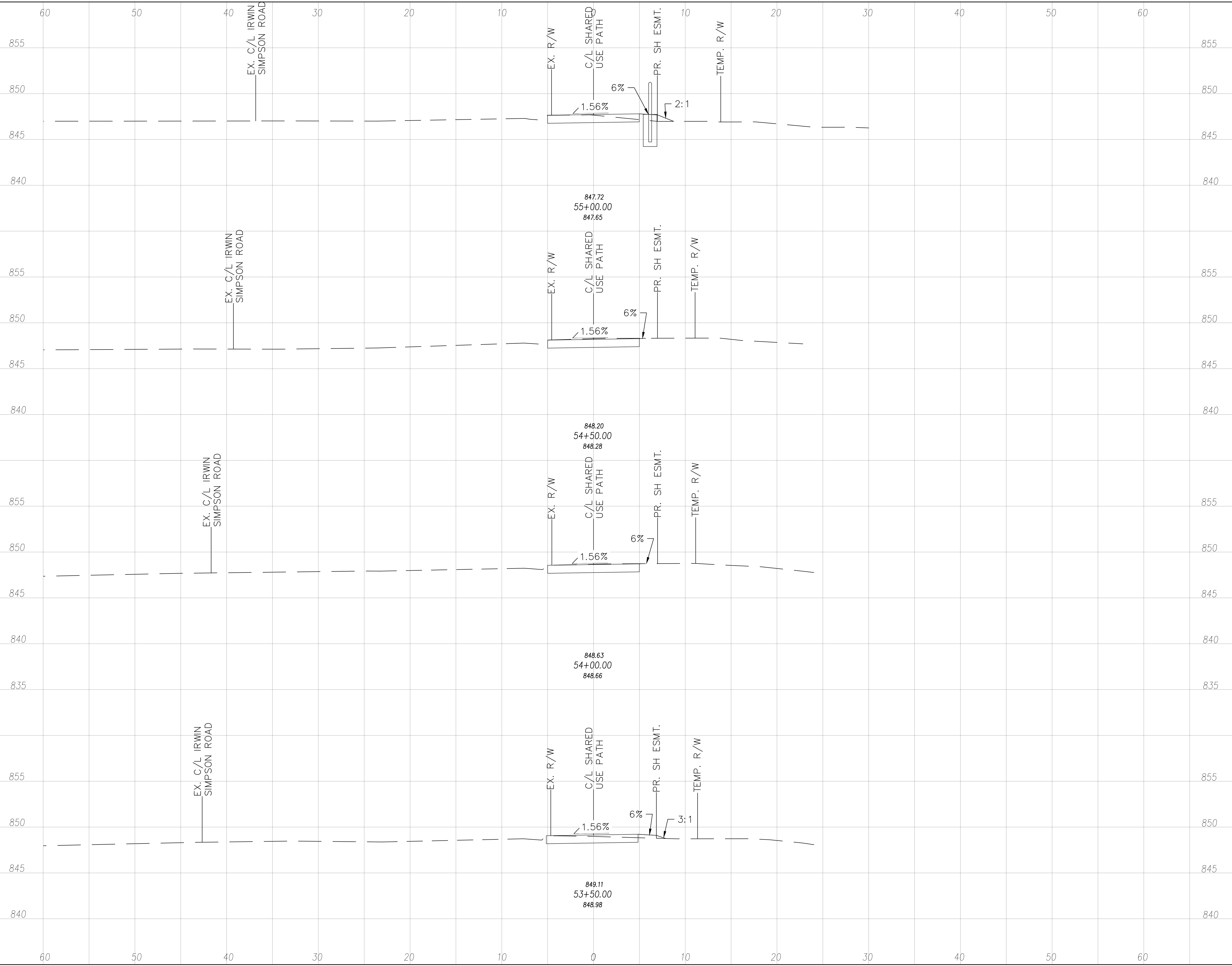

STATION	END AREA		VOLUME	
	CUT	FILL	CUT	FILL
18			13	2
4	7	2		
11			15	2
0	9	0		
2			17	0
0	9	0		
9			14	1
4	7	1		
2				
41	8	1	59	5

CROSS SECTIONS
53+50.00 TO 55+00.00

WAR - TR55 - 2.11

24
71

SEEDING	END WIDTH	SQ. YDS.	END AREA		VOLUME		CALCULATED	SCR	CHECKED	NW
			CUT	FILL	CUT	FILL				
6					16	0				
1			8	0						
9					15	0				
2			8	0						
13					14	1				
2			7	0						
14					13	1				
3			7	1						
2	42		8	0	59	2				

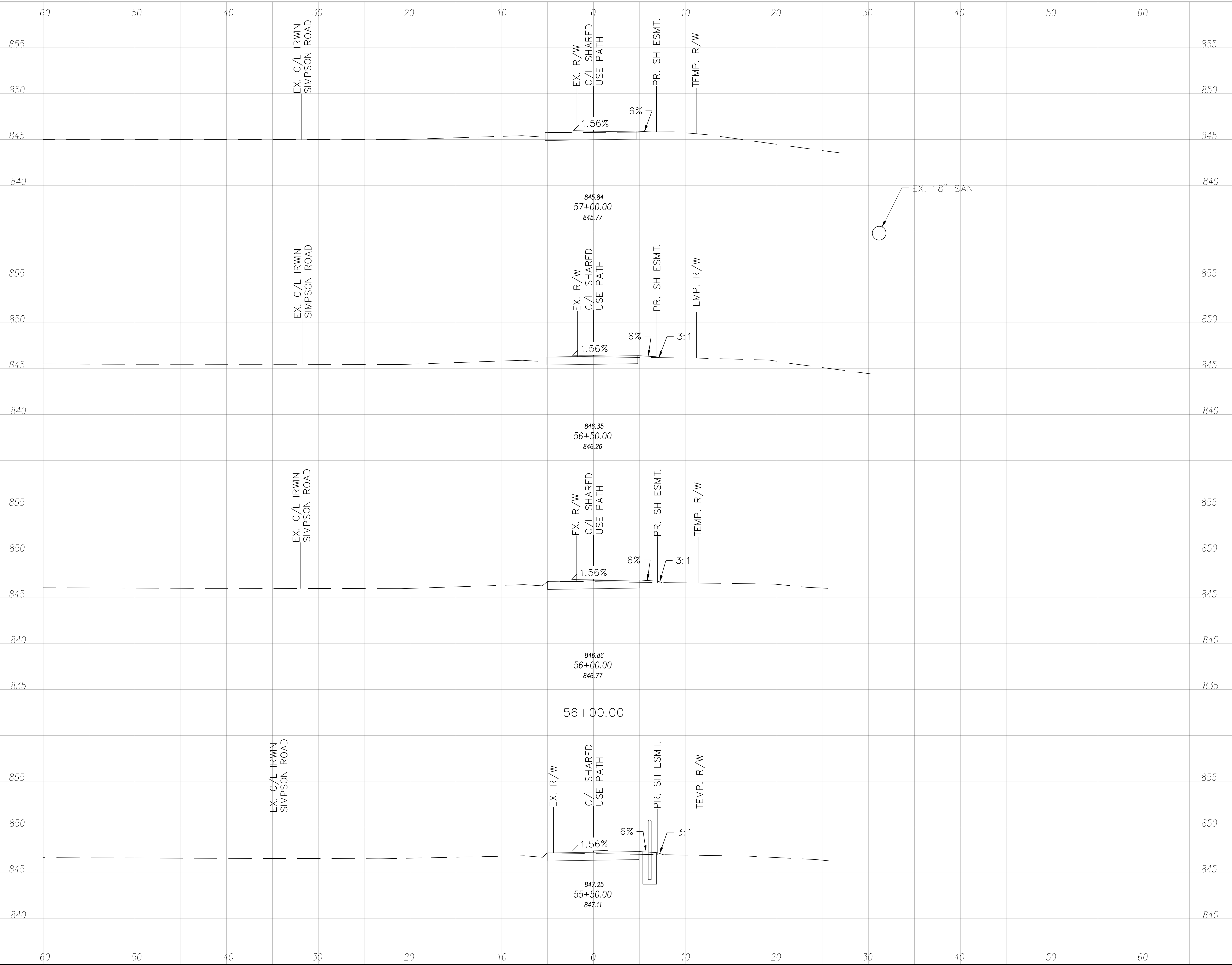

CROSS SECTIONS
55+50.00 TO 57+00.00

WAR-TR55-2.11

F:\Projects\688800\05_Deliverables\Drawings\114603\Design\Roadway\Sheets\114603XS001.dwg 19-Sep-23 3:44 PM

SEEDING	END	
	WIDTH	SQ. YDS.
52	96	9



END	AREA		VOLUME	
	CUT	FILL	CUT	FILL
7	1	1	50	24
7	1	1	13	2
7	1	1	13	1
7	1	1	15	1
9	0	0	9	0

CROSS SECTIONS
57+50.00 TO 59+00.00

WAR-TR55-2.11

26
71

F:\Projects\688800\05_Deliverables\Drawings\114603\Design\Roadway\Sheets\114603XS001.dwg 19-Sep-23 3:44 PM

SEEDING	END AREA		VOLUME		CALCULATED	SCR	CHECKED	NW
	CUT	FILL	CUT	FILL				
7			16	0				
2	8	0	14	1				
3	7	1	14	1				
2	8	0	10	20				
16	3	21	53	22				
6	6	6	53	22				



CROSS SECTIONS
59+50.00 TO 61+00.00

WAR-TR55-2.11

F:\Projects\688800\05_Deliverables\Drawings\114603\Design\Roadway\Sheets\114603XS001.dwg 19-Sep-23 3:45 PM

SEEDING	END SQ.	
	WIDTH	YDS.
23	60	75

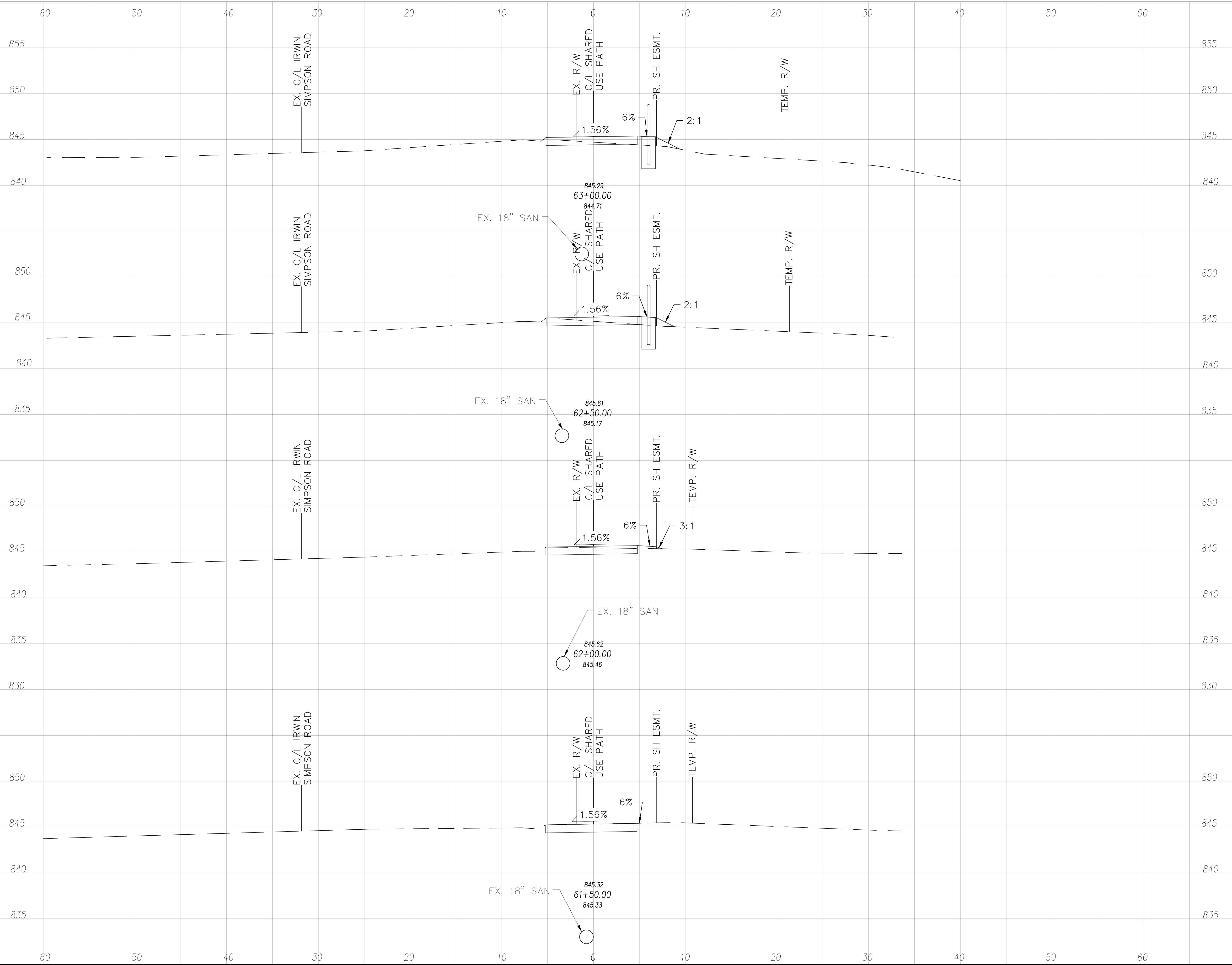

END	AREA		VOLUME	
	CUT	FILL	CUT	FILL
855			10	4
850				
845	4	3		
840				
850			7	5
845				
840	4	3		
835				
850			10	3
845				
840	7	1		
835				
830			15	1
850				
845	9	0		
840				
835				
6	2		42	13

CROSS SECTIONS
61+50.00 TO 63+00.00
WAR-TR55-2.11
28
71

SEEDING	END SQ.	
	WIDTH	YDS.
25	60	128

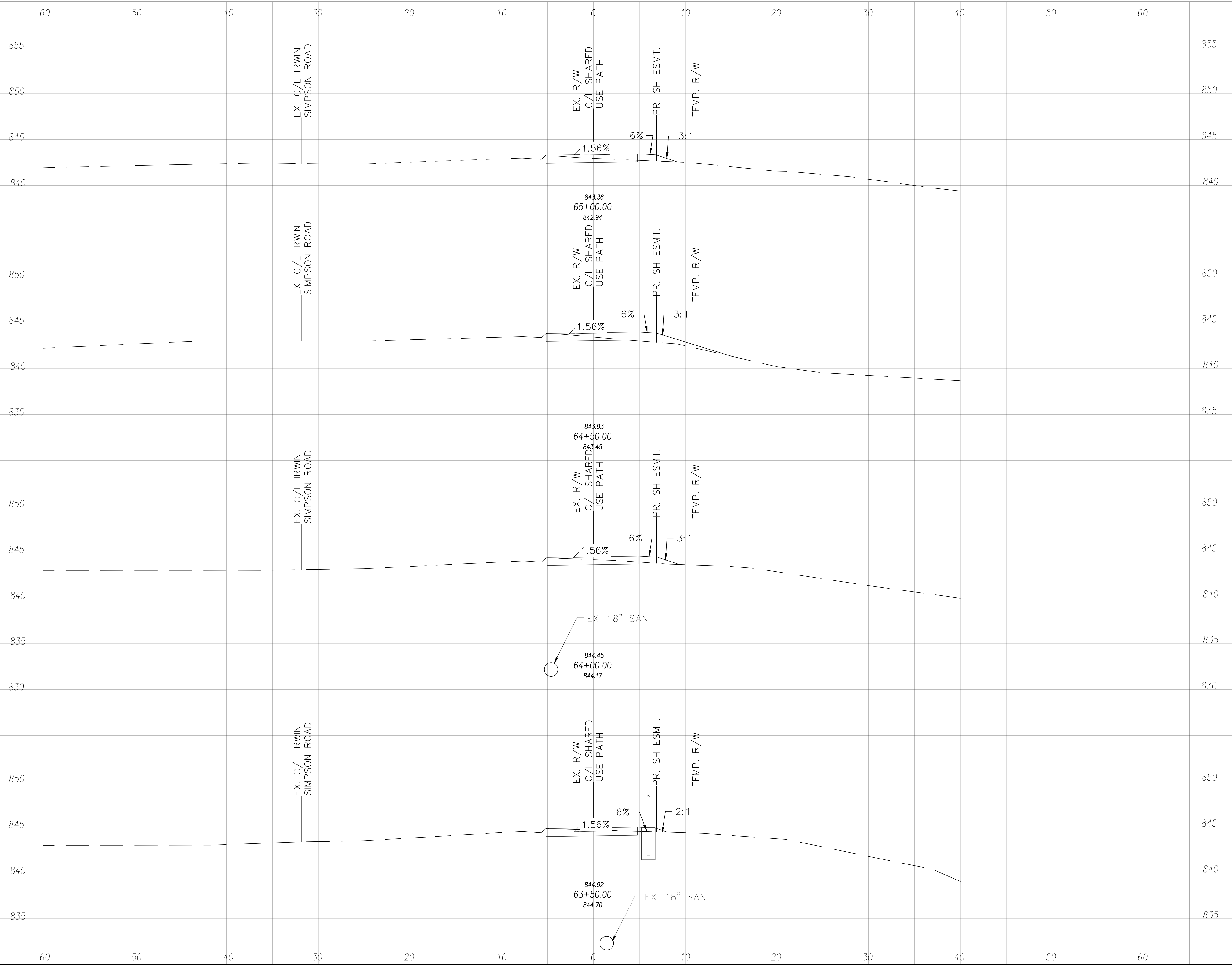

END	AREA		VOLUME	
	CUT	FILL	CUT	FILL
855			10	4
850				
845	5	2		
840				
835				
830				
825				
820				
815				
810				
805				
800				
795				
790				
785				
780				
775				
770				
765				
760				
755				
750				
745				
740				
735				
730				
725				
720				
715				
710				
705				
700				
695				
690				
685				
680				
675				
670				
665				
660				
655				
650				
645				
640				
635				
630				
625				
620				
615				
610				
605				
600				
595				
590				
585				
580				
575				
570				
565				
560				
555				
550				
545				
540				
535				
530				
525				
520				
515				
510				
505				
500				
495				
490				
485				
480				
475				
470				
465				
460				
455				
450				
445				
440				
435				
430				
425				
420				
415				
410				
405				
400				
395				
390				
385				
380				
375				
370				
365				
360				
355				
350				
345				
340				
335				
330				
325				
320				
315				
310				
305				
300				
295				
290				
285				
280				
275				
270				
265				
260				
255				
250				
245				
240				
235				
230				
225				
220				
215				
210				
205				
200				
195				
190				
185				
180				
175				
170				
165				
160				
155				
150				
145				
140				
135				
130				
125				
120				
115				
110				
105				
100				
95				
90				
85				
80				
75				
70				
65				
60				
55				
50				
45				
40				
35				
30				
25				
20				
15				
10				
5				

CROSS SECTIONS
63+50.00 TO 65+00.00

WAR-TR55-2.11

29
71

SEEDING	END	
	WIDTH	SQ. YDS.
27	60	850
2	60	840
11	60	840
22	60	840
72	60	840
4	60	840
8	177	830

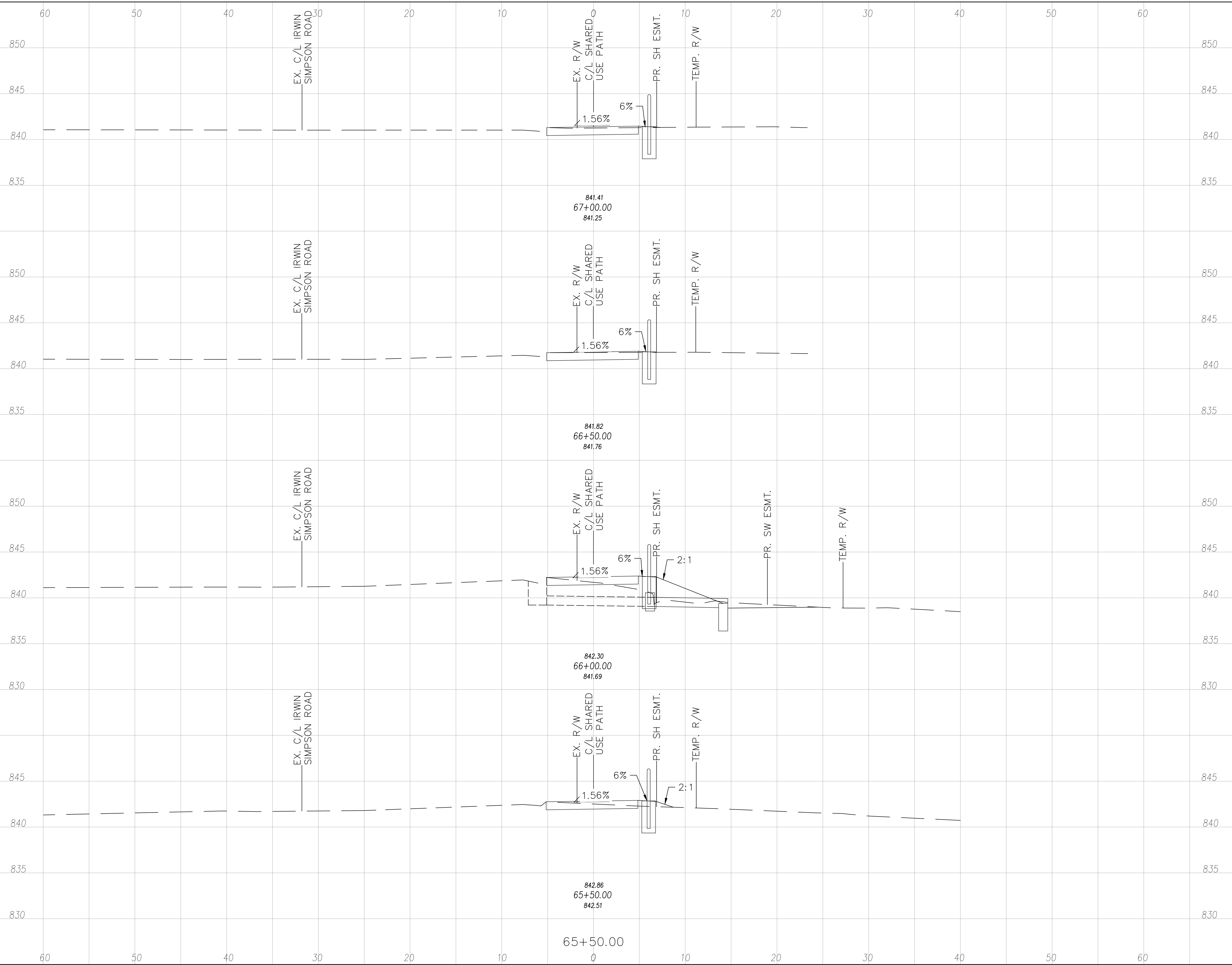

END AREA		VOLUME	
CUT	FILL	CUT	FILL
8	0	12	7
8	0	15	0
6	15	13	14
6	2	11	15
7	4	51	36

CROSS SECTIONS
65+50.00 TO 67+00.00

WAR-TR55-2.11

30
71

SEEDING	END SQ.	
	WIDTH	YDS.
31	60	102

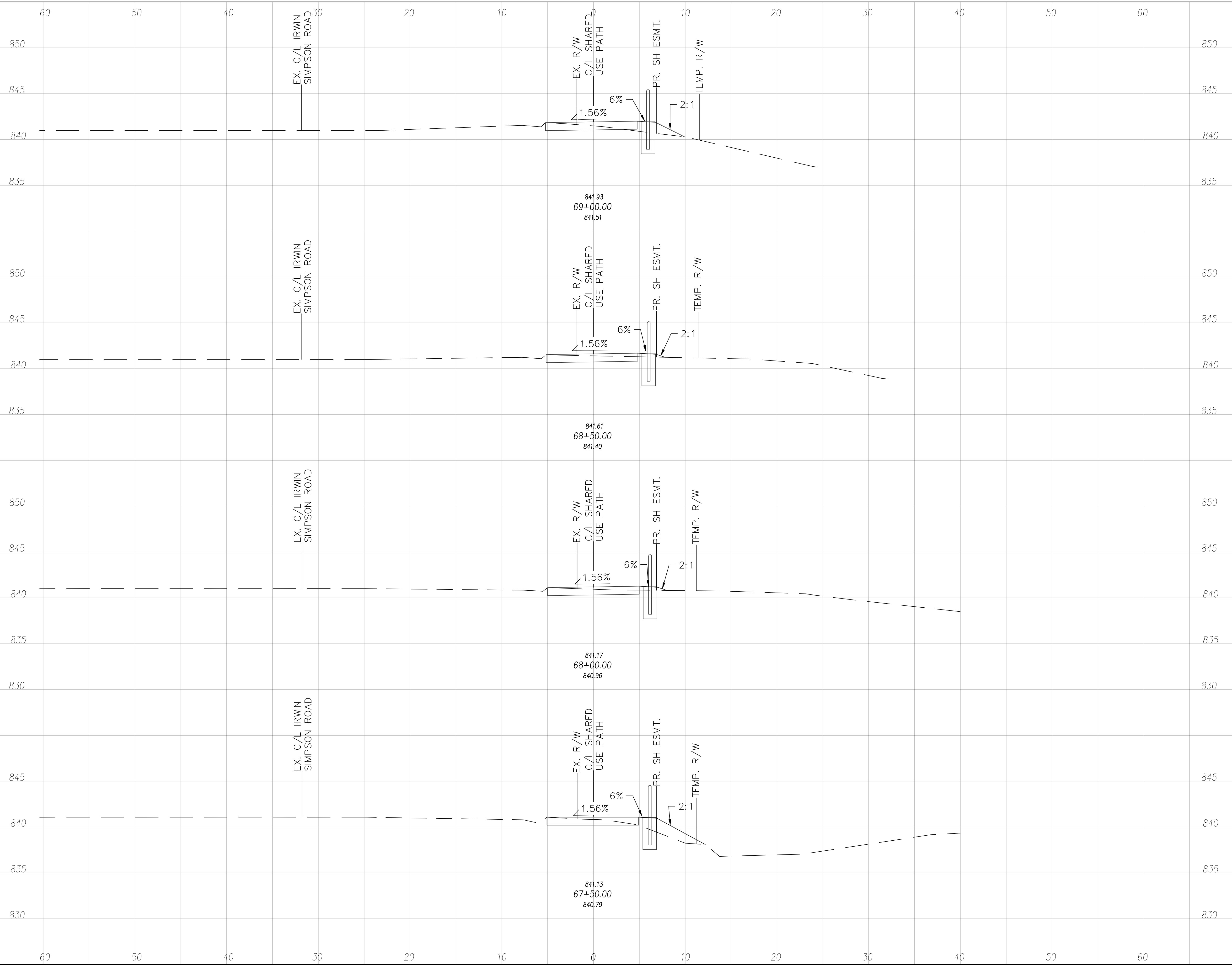

END	AREA		VOLUME	
	CUT	FILL	CUT	FILL
6	4	4	7	7
24	7	1	10	5
17	7	1	12	2
30	6	8	11	8
5	6	3	41	21

CROSS SECTIONS
67+50.00 TO 69+00.00

WAR-TR55-2.11

31
71

SEEDING	END	
	WIDTH	SQ. YDS.
31	60	113

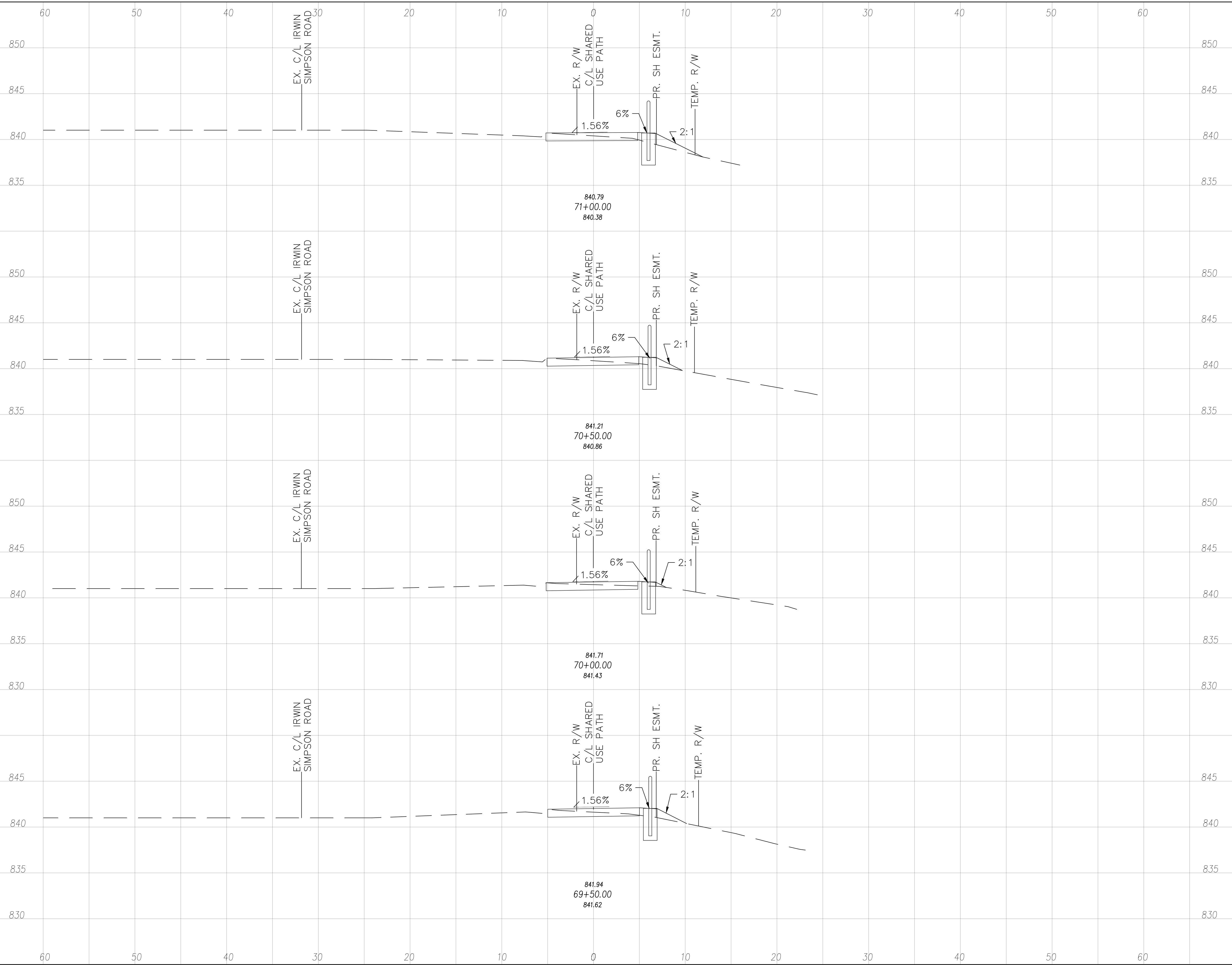

END AREA		VOLUME	
CUT	FILL	CUT	FILL
6	5	11	6
5	3	10	8
6	1	10	4
4	3	10	4
5	3	41	22

CROSS SECTIONS
69+50.00 TO 71+00.00

WAR-TR55-2.11

32
71

SEEDING	END WIDTH	SQ. YDS.	END AREA		VOLUME		CALCULATED	SCR	CHECKED	NW
			CUT	FILL	CUT	FILL				
41	60	850			5	17				
7	60	840	3	6						
29	60	850			9	6				
3	60	840	6	1						
23	60	845			8	5				
5	60	835	2	4						
24	60	825			8	5				
4	60	840	6	1						
5	60	830								
117	60	830	4	3	29	33				

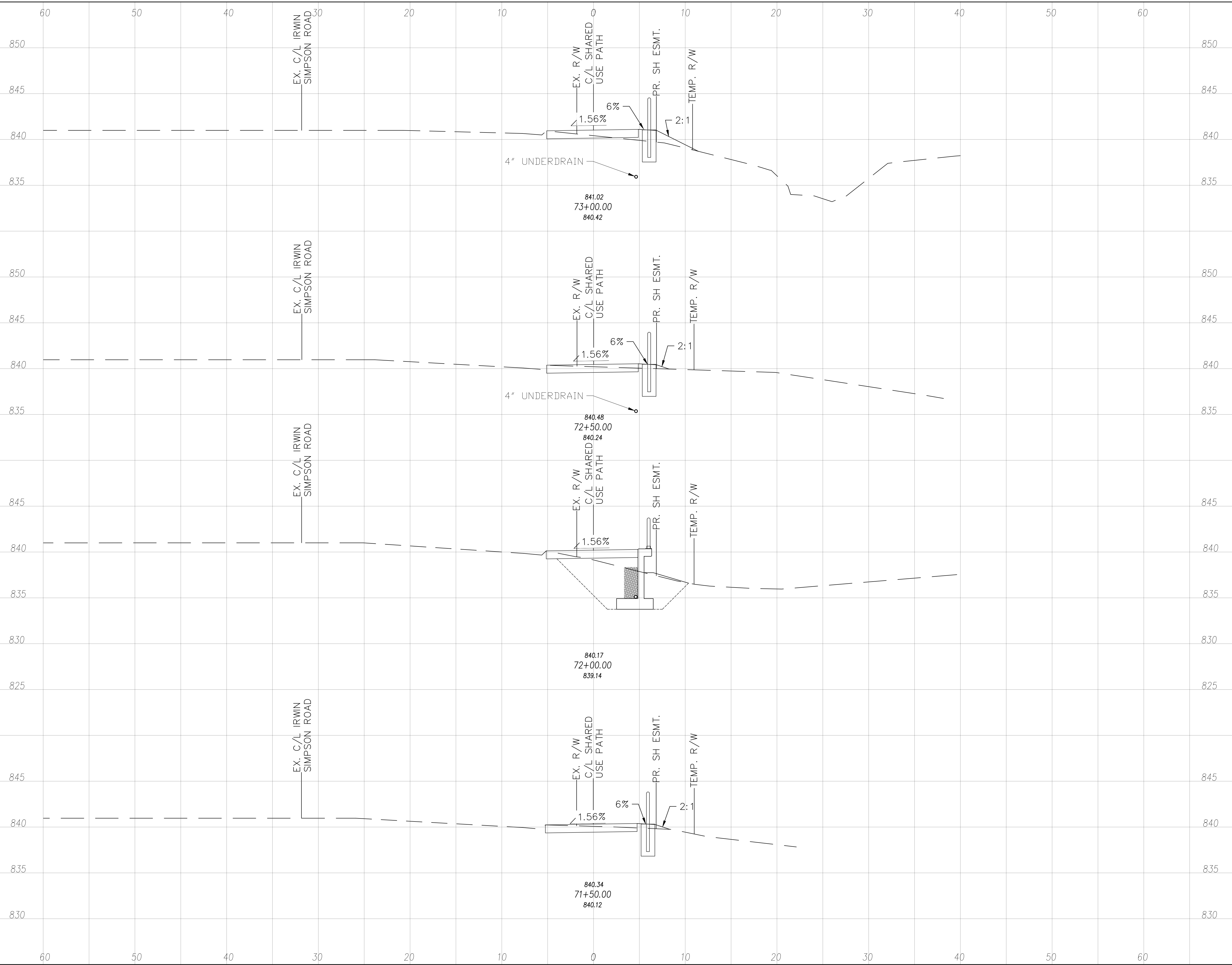

END AREA	VOLUME	CALCULATED	SCR	CHECKED	NW
3	6				
6	1				
8	5				
2	4				
8	5				
6	1				
4	3	29	33		

CROSS SECTIONS
71+50.00 TO 73+00.00
WAR-TR55-2.11

SEEDING	END	
	WIDTH	SQ. YDS.
16	60	105

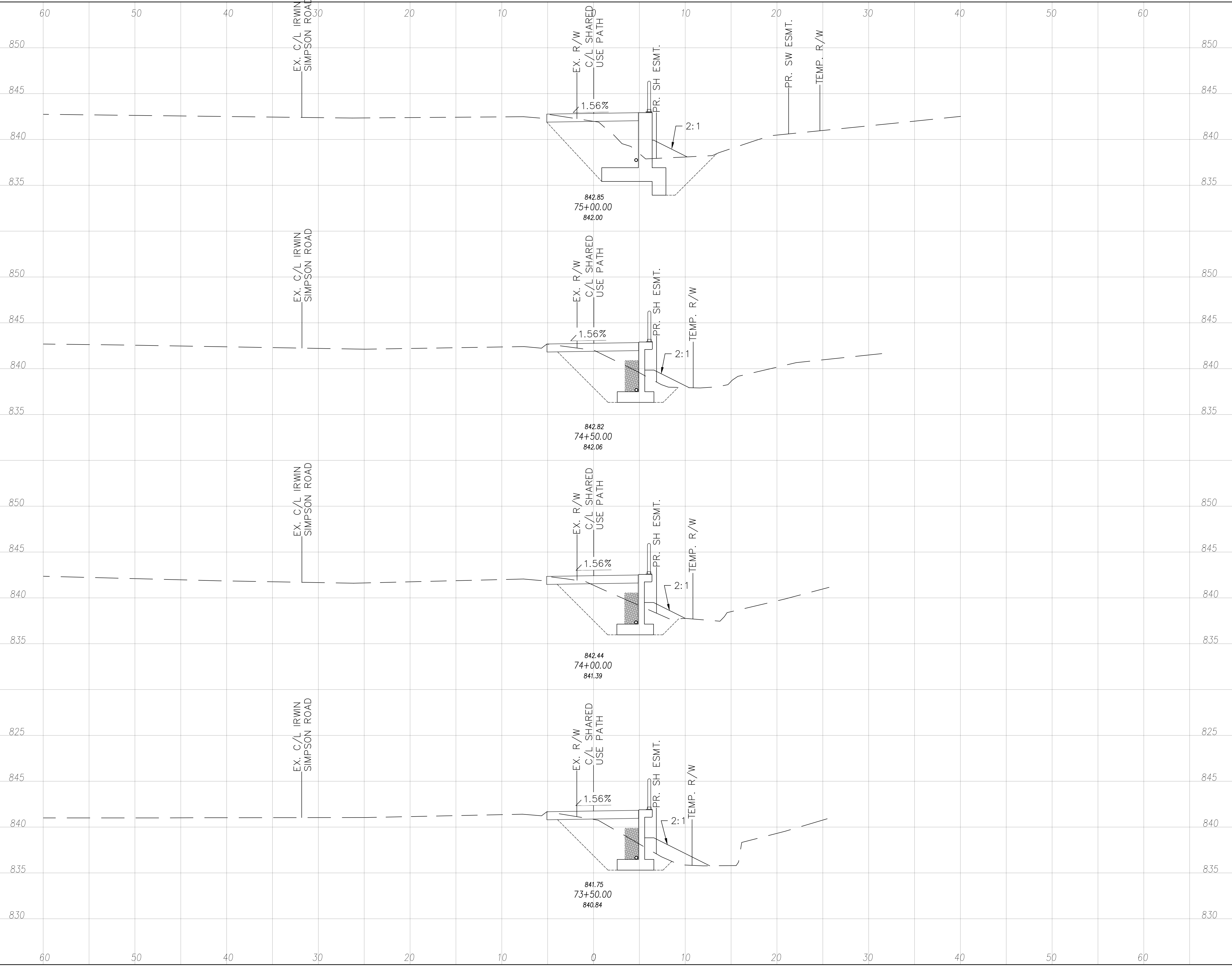

END AREA		VOLUME	
CUT	FILL	CUT	FILL
2	10	22	64
2	12	4	18
2	8	4	15
2	8	4	20
2	13	9	11

CROSS SECTIONS
73+50.00 TO 75+00

WAR-TR55-2.11

34
71

SEEDING	END SQ.	
	WIDTH	YDS.
5	107	

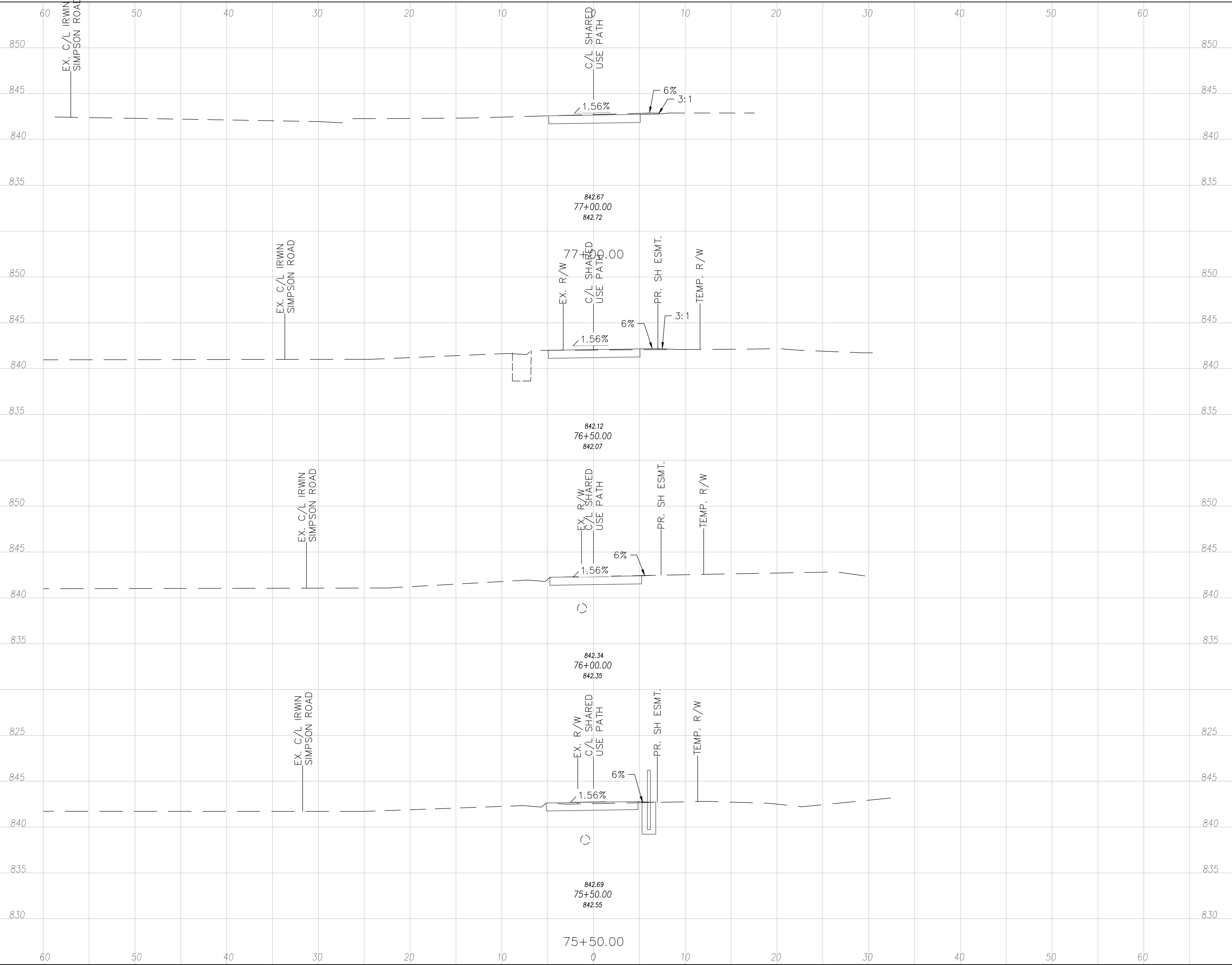

END AREA		VOLUME	
CUT	FILL	CUT	FILL
9	0	16	0
9	0	16	0
9	0	16	0
9	0	15	0
8	0	48	0

CROSS SECTIONS
75+50.00 TO 77+00.00

WAR-TR55-2.11

35
71

B/W - BACK OF WALK
 F/C - FACE OF CURB
 T/C - TOP OF CURB

F:\Projects\688800\05_Deliverables\Drawings\114603\Roadway\Sheets\114603GI000.dwg 19-Sep-23 3:49 PM

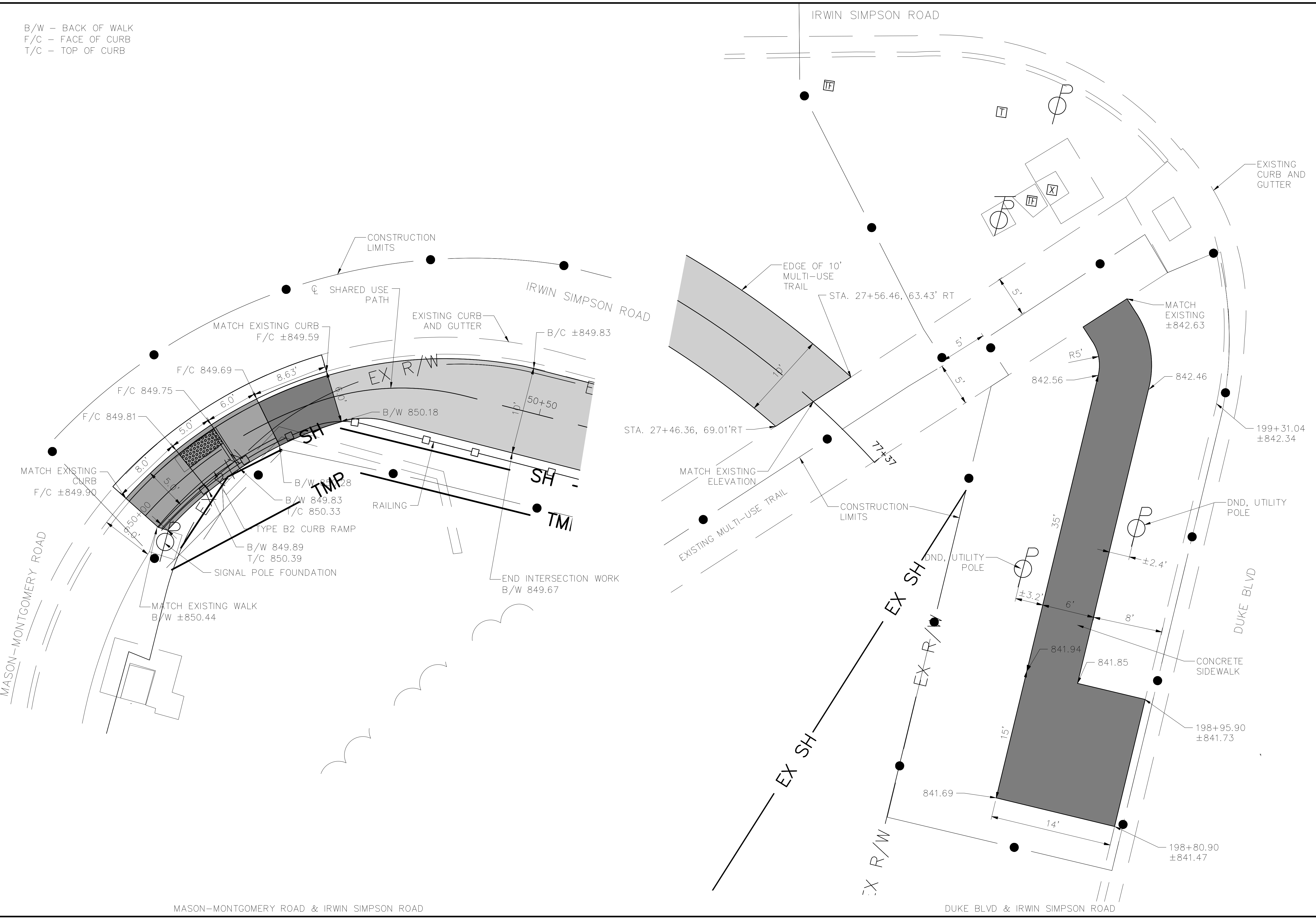

CALCULATED
 SCR
 CHECKED
 NW

0 5 10
 2.5
 HORIZONTAL
 SCALE IN FEET

INTERSECTION DETAILS

WAR-TR55-2.11

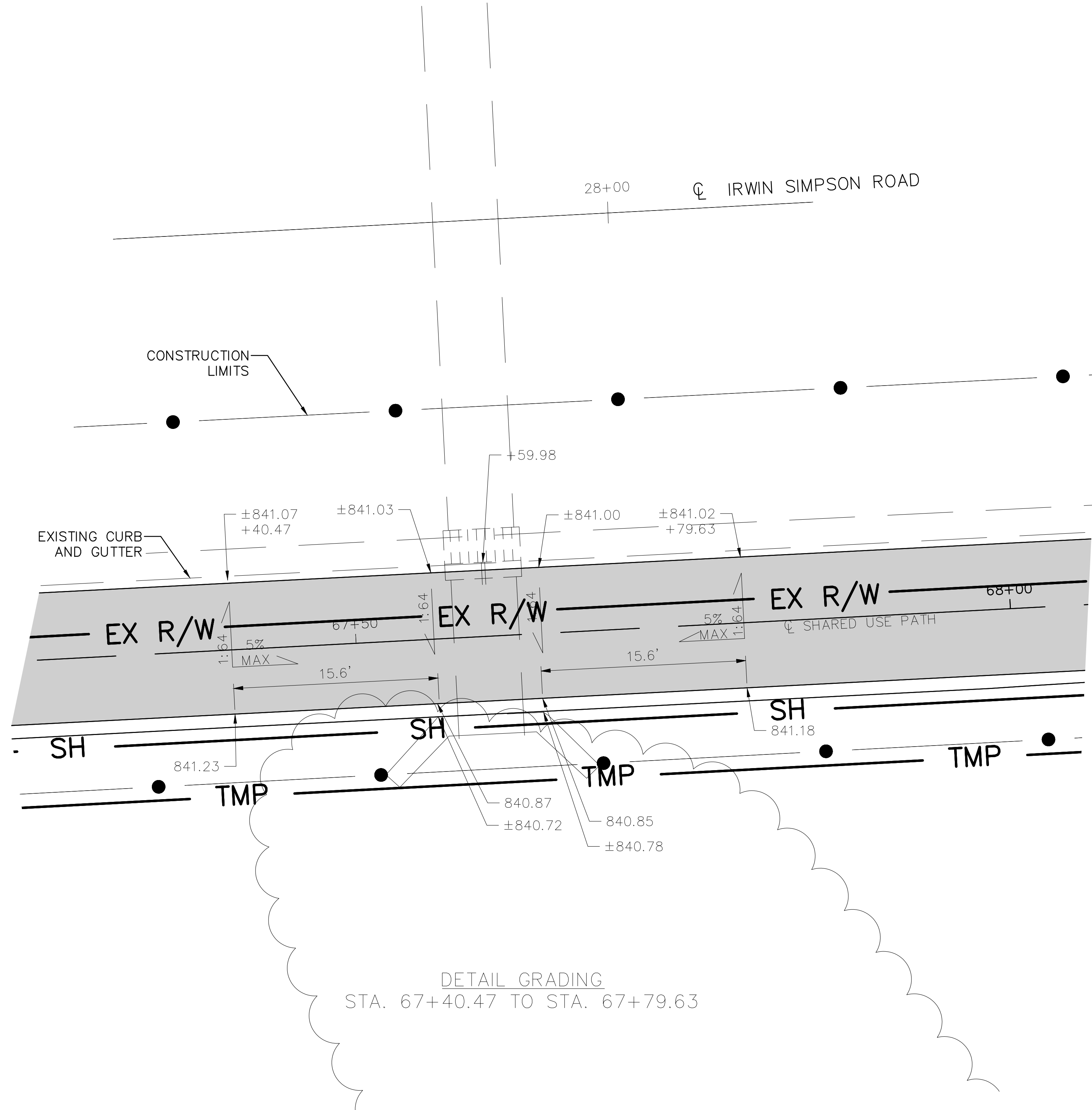

DETAIL GRADING
STA. 67+40.47 TO STA. 67+79.63

CALCULATED
SCR
CHECKED
NW

0 5 10
2.5
HORIZONTAL
SCALE IN FEET

DETAIL GRADING
STA. 67+40.47 TO STA. 67+79.63

WAR-TR55-2.11

ESTIMATED QUANTITIES					
ITEM	ITEM EXTENSION	TOTAL	UNIT	DESCRIPTION	SEE SHEET
203	20000	2.69	CY	EMBANKMENT	
503	21100	2	CY	UNCLASSIFIED EXCAVATION	
509	10000	1340	POUNDS	EPOXY COATED REINFORCING STEEL	
511	46612	16.84	CY	CLASS QC1 CONCRETE WITH QC/QA, HEADWALL	

NOTE:
CONTRACTOR TO VERIFY SIZE OF
EXISTING PIPE AND NOTIFY ENGINEER
OF ANY DISCREPANCIES PRIOR TO
INSTALLING HEADWALL.

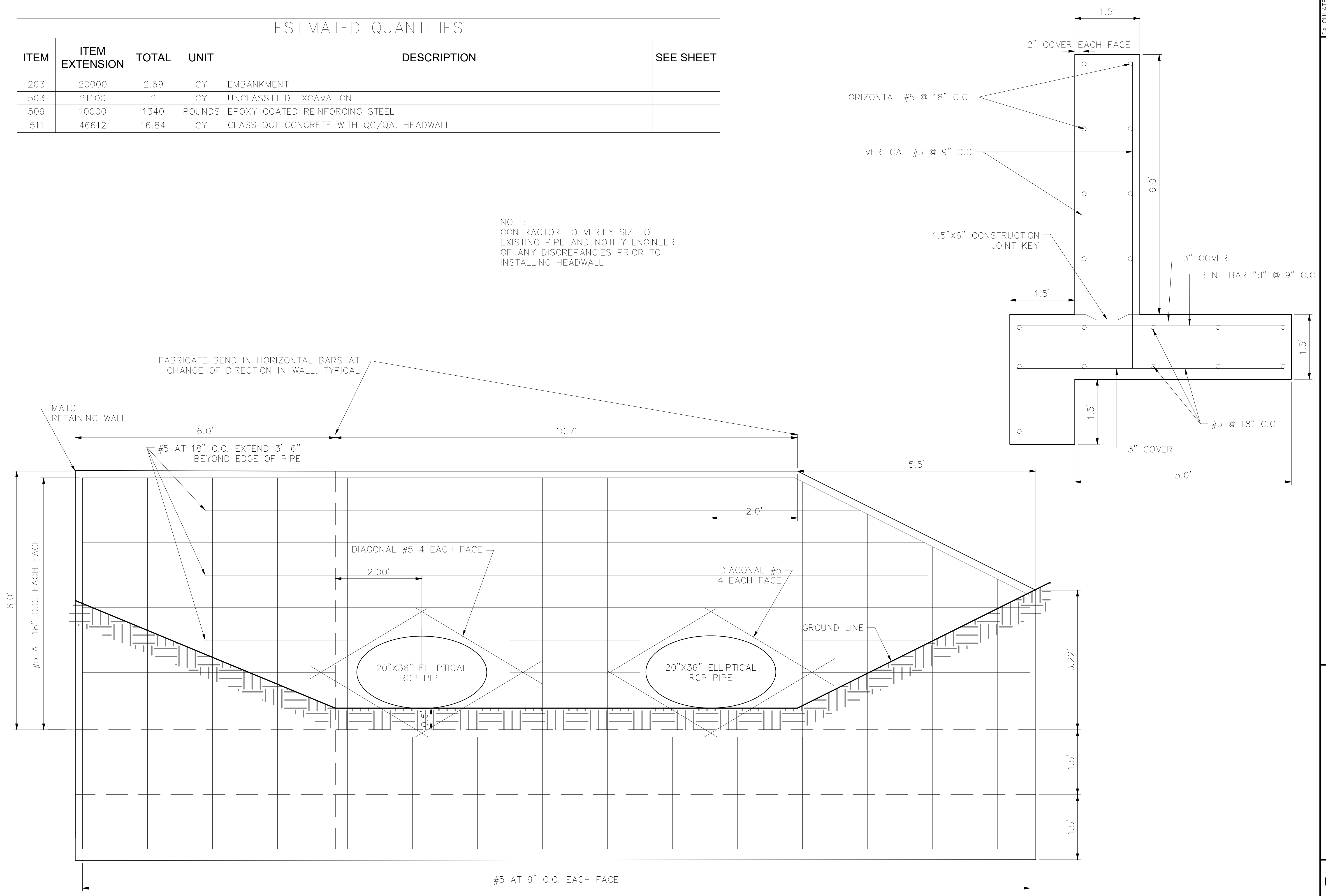

F:\Projects\688800\05_Deliverables\Drawings\114603\Design\Drainage_Sheets\114603DC001.dwg 19-Sep-23 3:50 PM

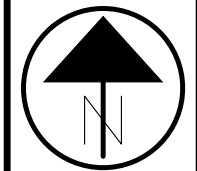

0 5 10 20
HORIZONTAL
SCALE IN FEET

DRAWN
SCR
CHECKED
M/M

HEADWALLS PLAN VIEW

WAR-TR55-2.11

1/1

39
71

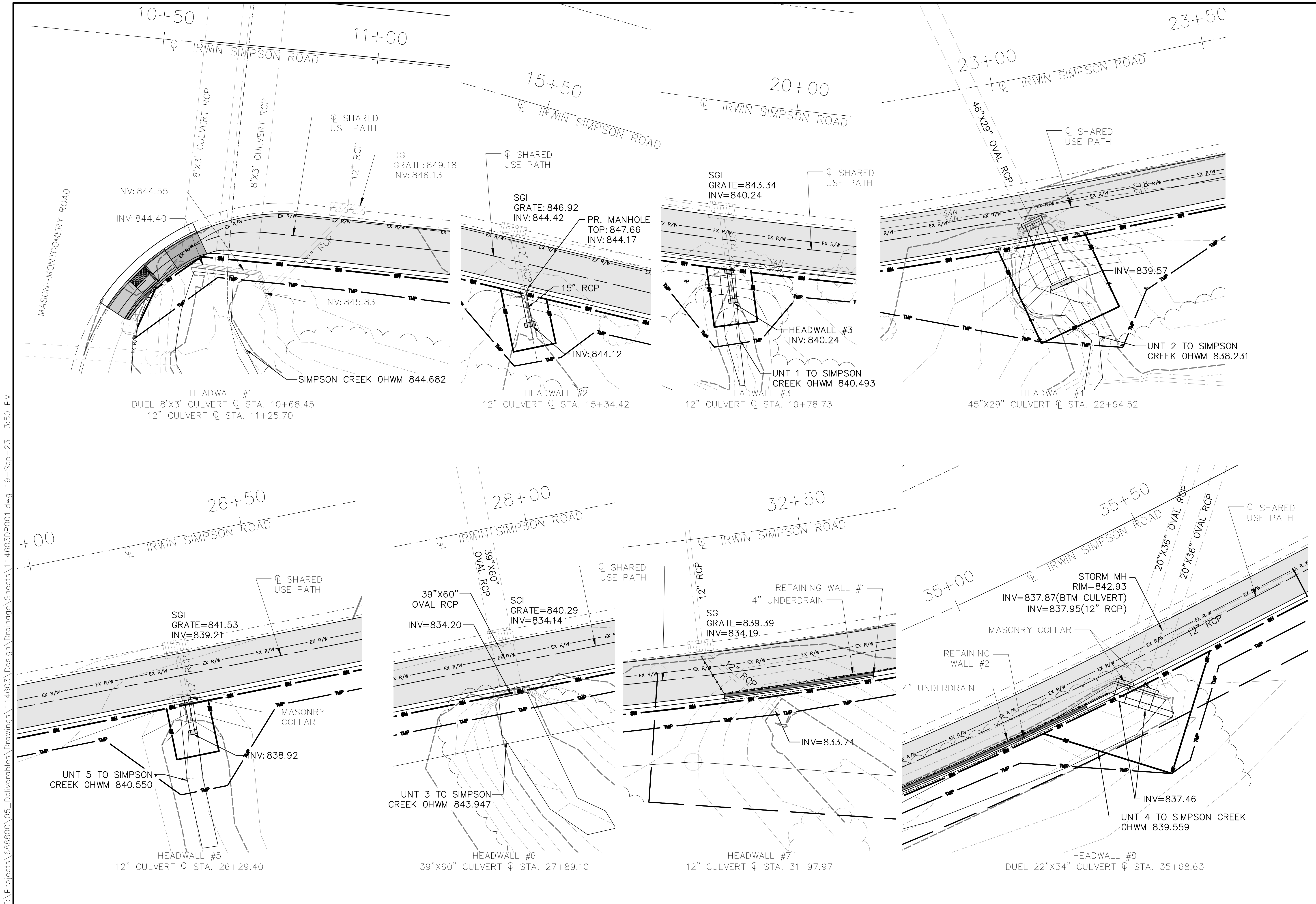

F:\Projects\688800\05_Deliverables\Drawings\114603\Drainage_Sheets\114603DP001.dwg 19-Sep-23 3:50 PM

SEEDING	
END WIDTH	SQ. YDS.
30	
20	
10	
0	
10	
20	
30	
40	
50	
60	
70	
80	
90	

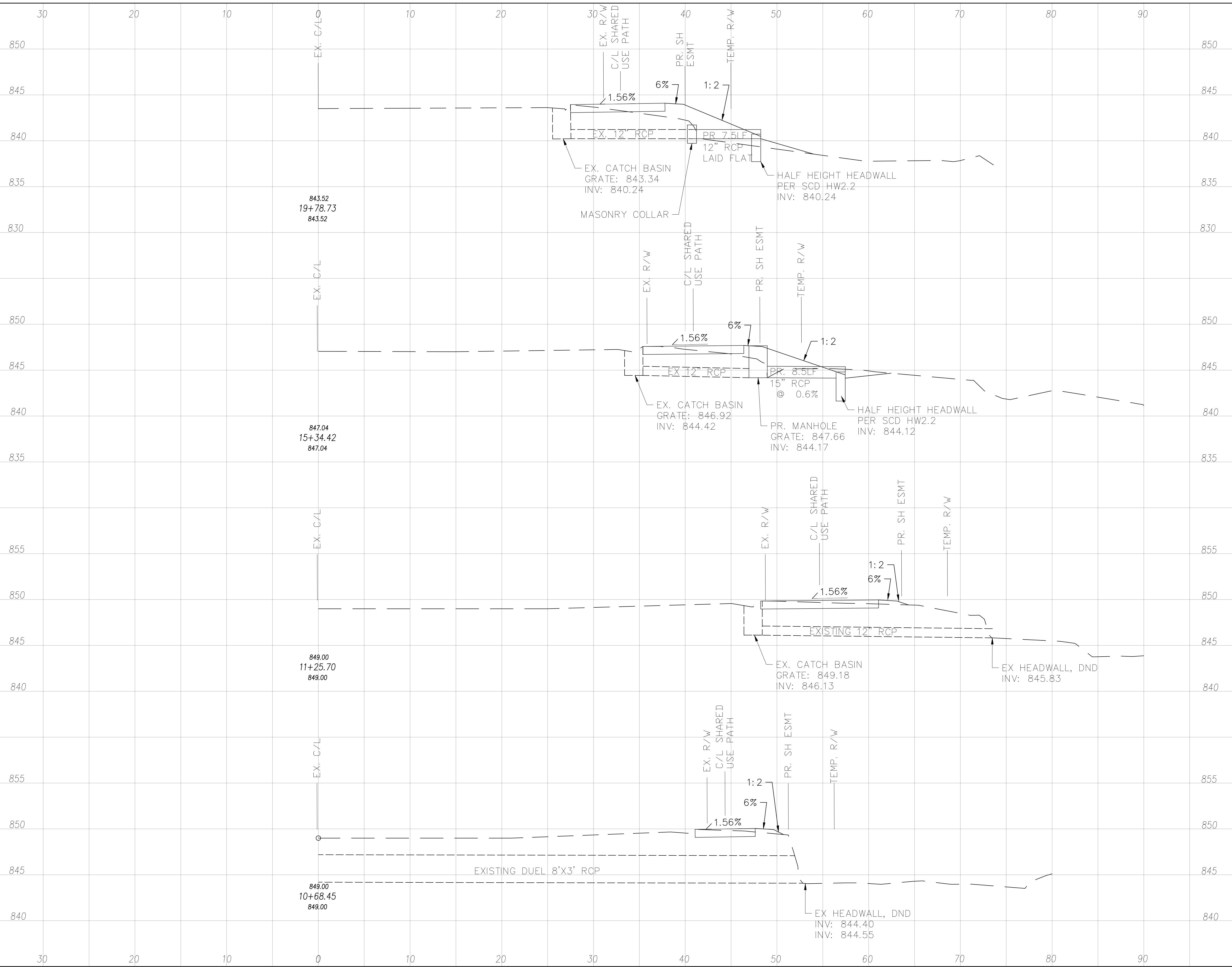

END	AREA		VOLUME	
	CUT	FILL	CUT	FILL
850				
845				
840				
835				
830				
850				
845				
840				
835				
855				
850				
845				
840				
855				
850				
845				
840				

CULVERT CROSS SECTIONS

WAR - TR55 - 2.11

40	71
----	----

SEEDING	
END WIDTH	SQ. YDS.
30	
20	
10	
0	
10	
20	
30	
40	
50	
60	
70	
80	
90	

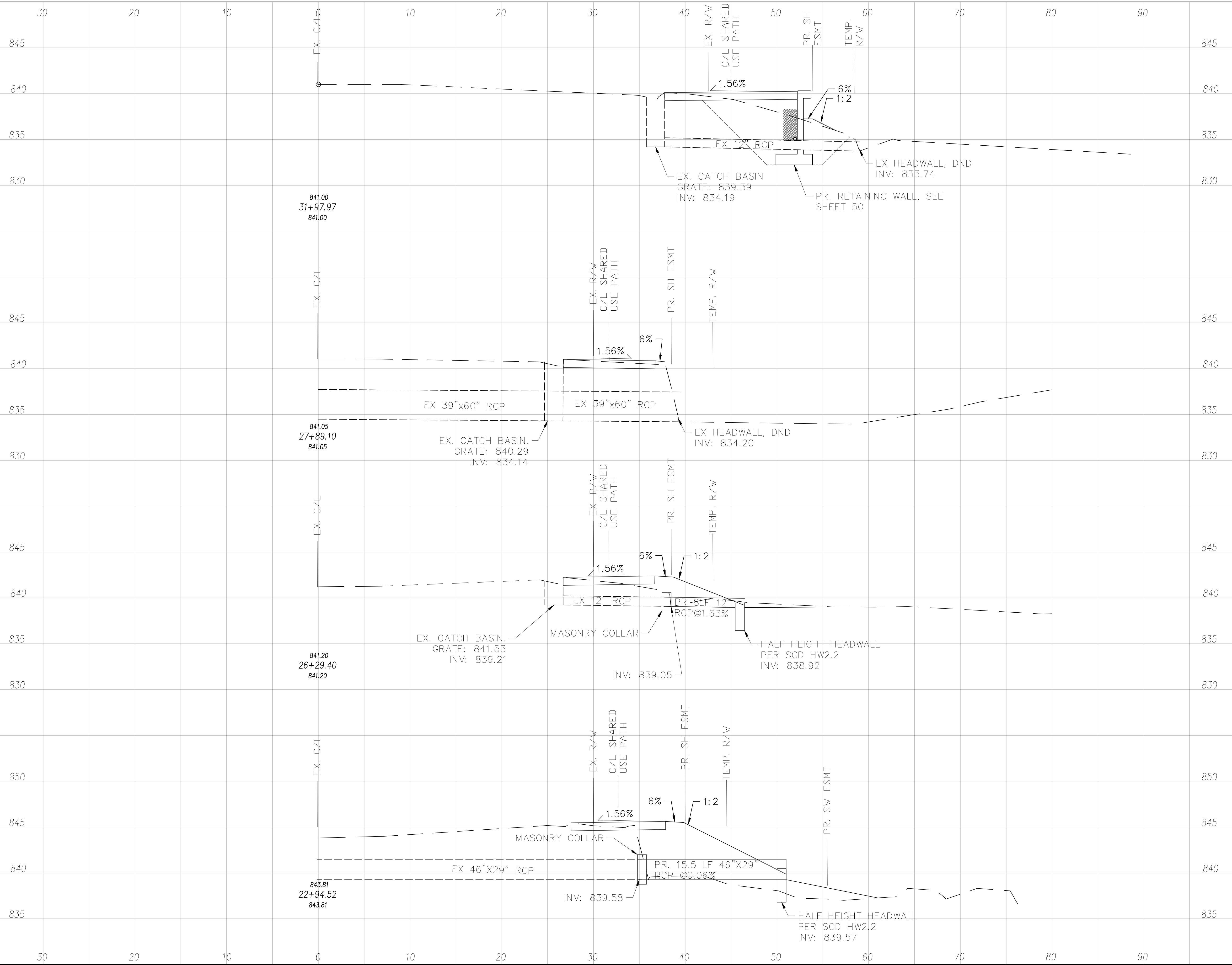

END	AREA		VOLUME	
	CUT	FILL	CUT	FILL
845				
840				
835				
830				
845				
840				
835				
830				
845				
840				
835				
830				
845				
840				
835				
830				
850				
845				
840				
835				

SEEDING	
END WIDTH	SQ. YDS.

END AREA		VOLUME	
CUT	FILL	CUT	FILL

CALCULATED	SCR	CHECKED	MAM

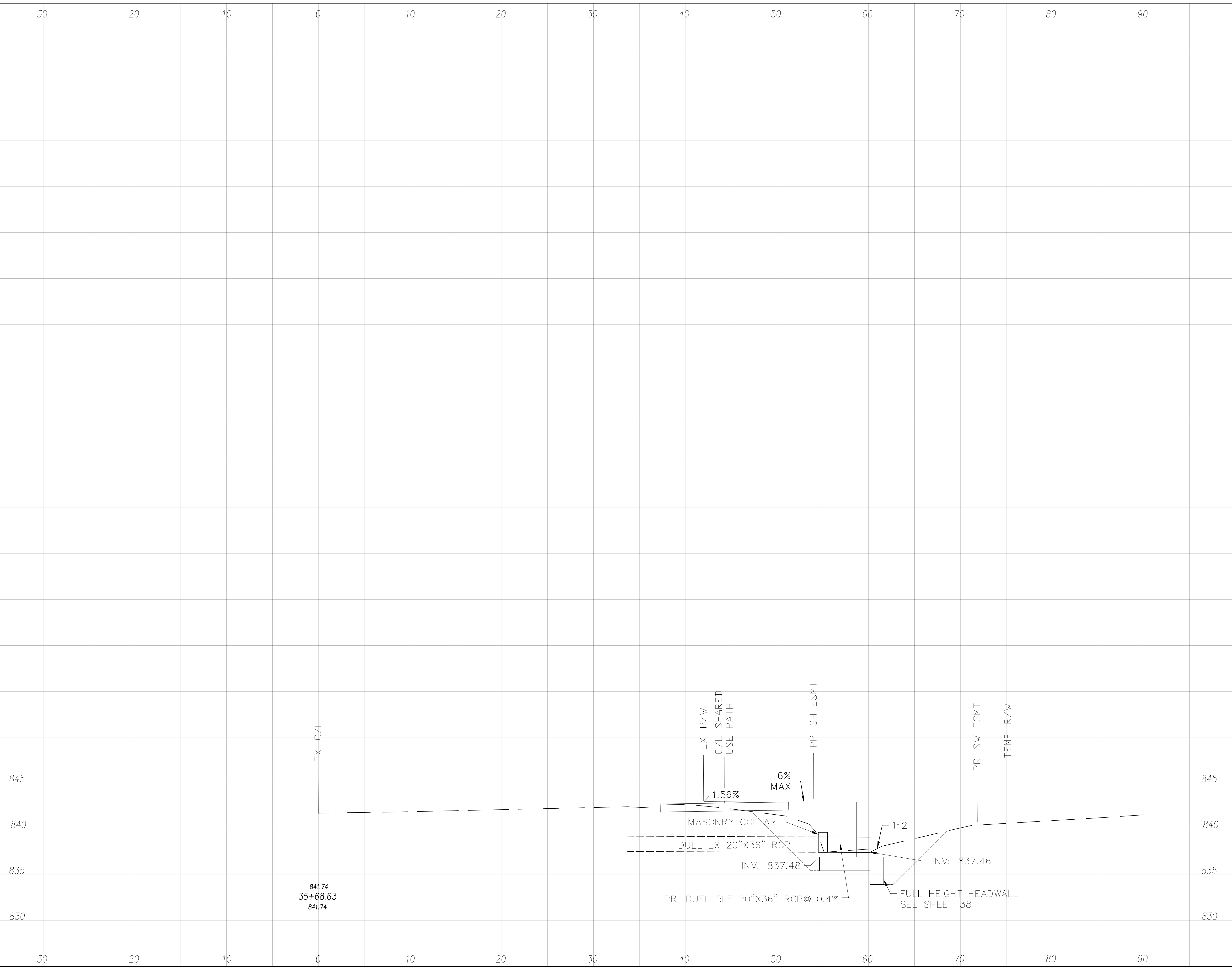

CULVERT CROSS SECTIONS

WAR - TR55 - 2.11

REF NO.	SHEET NO.	STATION TO STATION				CODE	SIZE (INCHES)	630	630	630	630	630	642																						
								GROUND MOUNTED SUPPORT, NO. 3 POST FT	REMOVAL OF GROUND MOUNTED SIGN AND DISPOSAL EACH	REMOVAL OF GROUND MOUNTED SIGN AND REERECTION EACH	REMOVAL OF GROUND MOUNTED SIGN AND DELIVERY EACH	REMOVAL OF GROUND MOUNTED POST SUPPORT AND DISPOSAL EACH	LANE LINE, 6", TYPE 1 MILE																						
S1	45	11+77.15	RT			R2-1	13		1																										
						METRO			1																										
S2	46	20+93.94	RT			R2-1	13		1																										
S3	47	25+27.32	RT			MAINT.				1	1																								
S4	48	32+01.55	RT			W3-P	13.5		1																										
						W3-H3P		1																											
S5	48	34+72.92	RT			R3-H8cg	13/13		1																										
LL-1	44	3+82.76	RT	TO	5+81.78	RT						0.04																							
LL-2	45-47	10+85.39	RT	TO	37+87.63	RT						0.51																							
TOTALS CARRIED TO GENERAL SUMMARY								65.5	1	5	1	1	0.55																						

CALCULATED
SCR
CHECKED
MAM

SUBSUMMARY

WAR - TR55 - 2.11

F:\Projects\688800\05_Deliverables\Drawings\114603\Design\Traffic\Sheets\114603TP000.dwg 19-Sep-23 3:52 PM

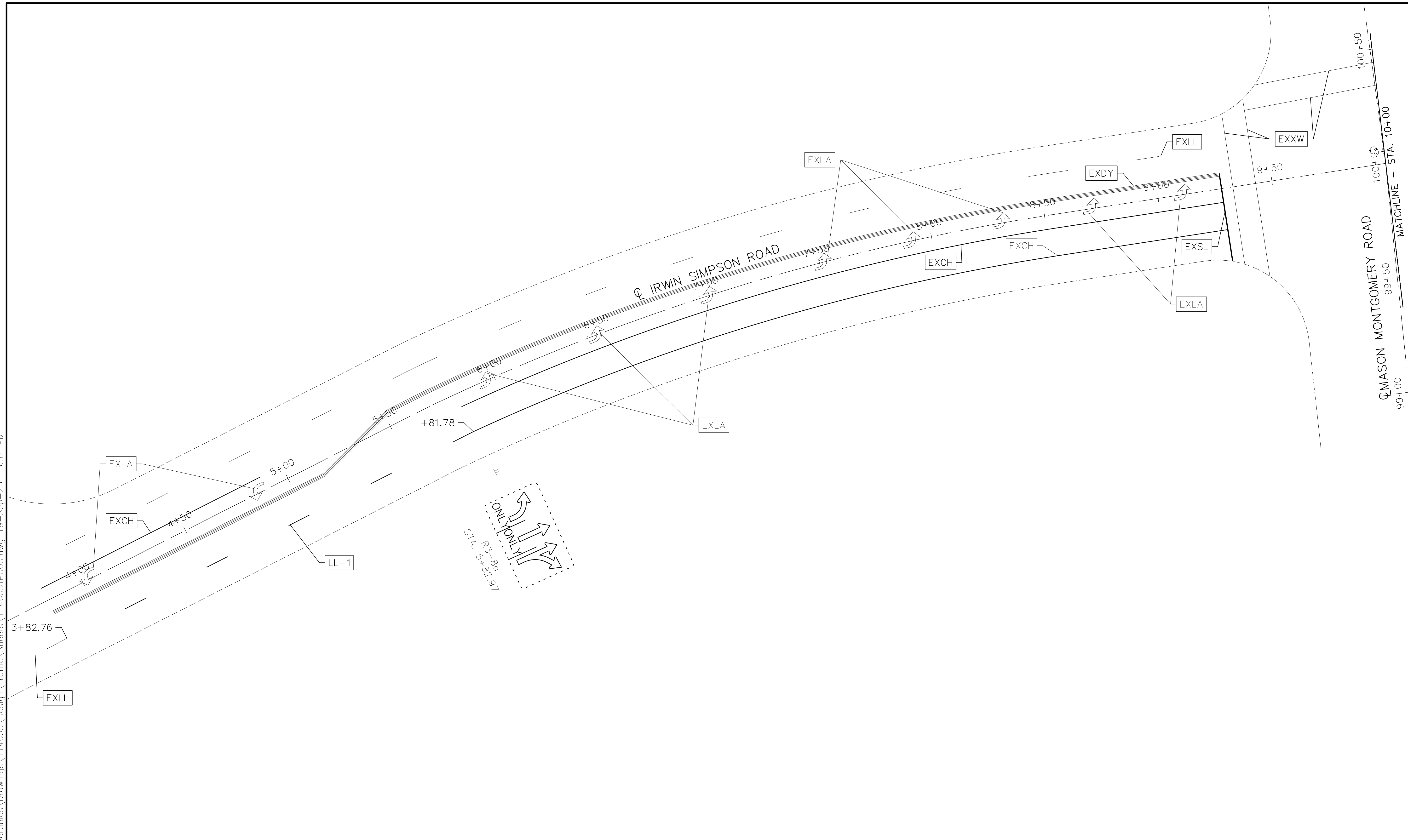

CALCULATED
SCR
CHECKED
NW

0 10 20
HORIZONTAL
SCALE IN FEET

SIGN AND PAVEMENT MARKING PLAN
STA. 3+50 TO STA. 10+00

WAR-TR55-2.11

PAVEMENT MARKING LEGEND	
EL	EDGE LINE, 6" WHITE
CH	CHANNELIZING LINE, 6" WHITE
DY	CENTER LINE, SOLID DOUBLE YELLOW
DL	DOTTED LINE, 8" WHITE
WP	WORD ON PAVEMENT
LL	LANE LINE, 6" WHITE
SL	STOP LINE
XW	CROSS WALK
LA	LANE ARROW

(EX = EXISTING)

SIGN LEGEND	
	REMOVE SIGN
	EXISTING SIGN TO REMAIN
	PROPOSED SIGN
	EXISTING SIGN TO BE REMOVED AND RE-ERECTED ON NEW POST

NOTES

- EXISTING PAVEMENT MARKINGS FROM AERIAL PHOTOS.
- ALL SIGNS ARE LOCATED PER AERIAL PHOTOS

F:\Projects\688800\05_Deliverables\Drawings\114603\Design\Traffic\Sheets\114603TP000.dwg 19-Sep-23 3:52 PM

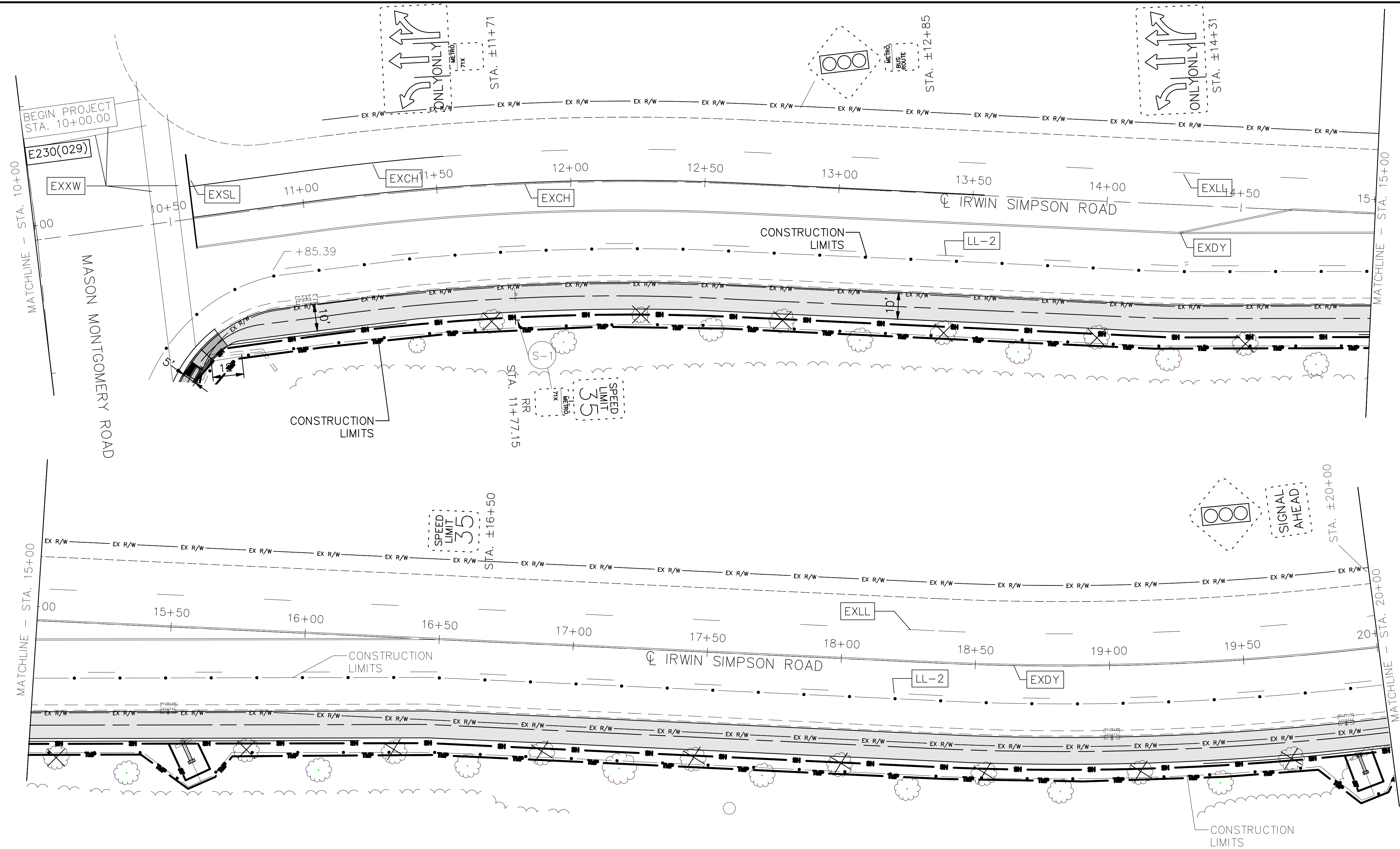

CALCULATED 0
 SCR 10
 CHECKED NW 40
 HORIZONTAL SCALE IN FEET

SIGN AND PAVEMENT MARKING PLAN
 STA. 10+00 TO STA. 20+00

PAVEMENT MARKING LEGEND

EL	EDGE LINE, 6" WHITE	LL	LANE LINE, 6" WHITE
CH	CHANNELIZING LINE, 6" WHITE	SL	STOP LINE
DY	CENTER LINE, SOLID DOUBLE YELLOW	XW	CROSS WALK
DL	DOTTED LINE, 8" WHITE	LA	LANE ARROW
WP	WORD ON PAVEMENT		

(EX = EXISTING)

SIGN LEGEND

	REMOVE SIGN		EXISTING SIGN TO BE REMOVED AND RE-ERECTED ON NEW POST
	EXISTING SIGN TO REMAIN		
	PROPOSED SIGN		

NOTES

- EXISTING PAVEMENT MARKINGS FROM AERIAL PHOTOS.
- SIGNS ON THE NORTH SIDE OF IRWIN SIMPSON ROAD ARE LOCATED PER AERIAL PHOTOS.

WAR-TR55-2.11

F:\Projects\688800\05_Deliverables\Drawings\114603\Design\Traffic\Sheets\114603TP000.dwg 19-Sep-23 3:52 PM

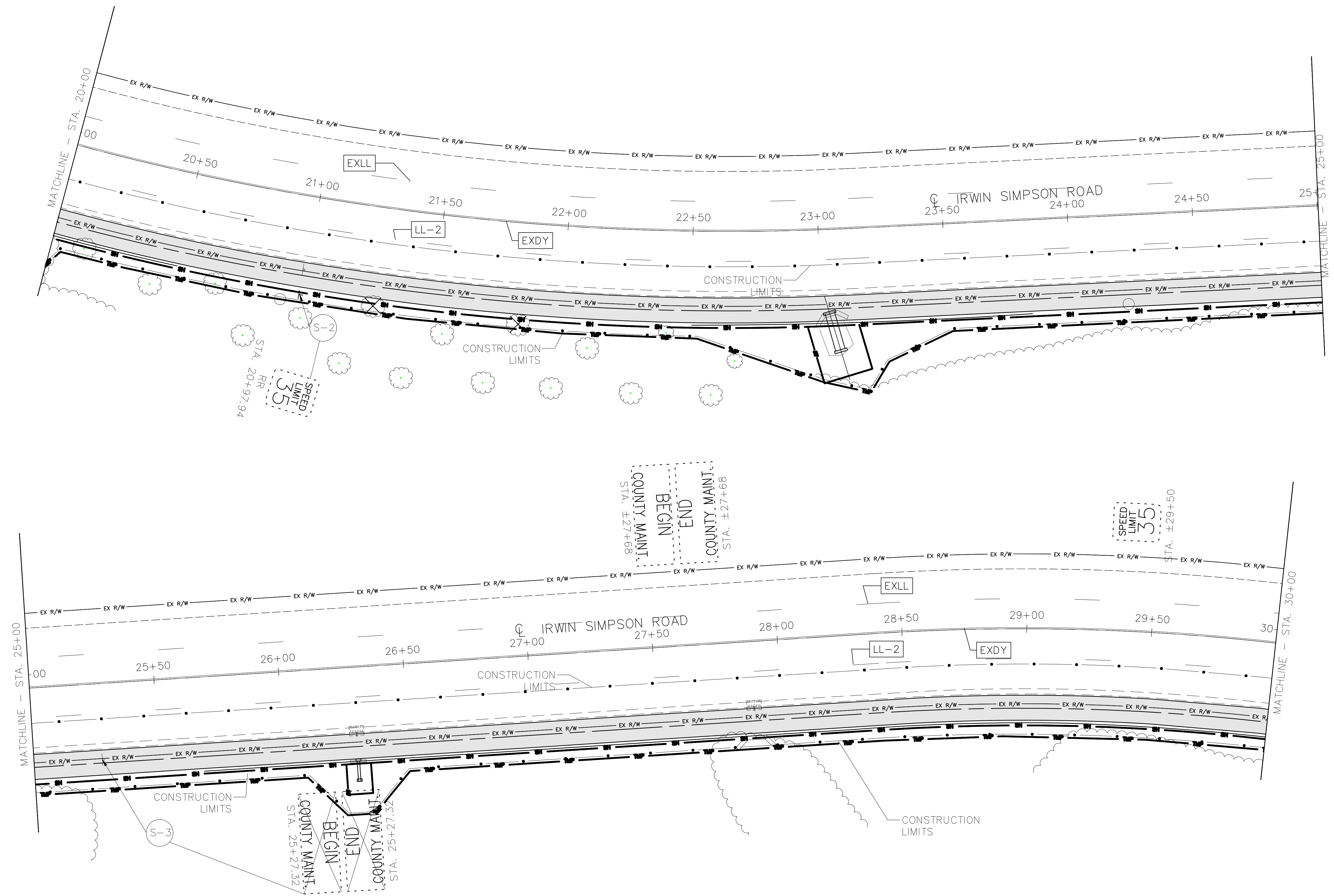

CALCULATED
SCR
CHECKED
NW

0 20 40
10
HORIZONTAL
SCALE IN FEET

SIGN AND PAVEMENT MARKING PLAN
STA. 20+00 TO STA. 30+00

WAR-TR55-2.11

PAVEMENT MARKING LEGEND	
EL	EDGE LINE, 6" WHITE
CH	CHANNELIZING LINE, 6" WHITE
DY	CENTER LINE, SOLID DOUBLE YELLOW
DL	DOTTED LINE, 8" WHITE
WP	WORD ON PAVEMENT
LL	LANE LINE, 6" WHITE
SL	STOP LINE
XW	CROSS WALK
LA	LANE ARROW

(EX = EXISTING)

SIGN LEGEND	
	REMOVE SIGN
	EXISTING SIGN TO REMAIN
	PROPOSED SIGN
	EXISTING SIGN TO BE REMOVED AND RE-ERECTED ON NEW POST

- NOTES
- EXISTING PAVEMENT MARKINGS FROM AERIAL PHOTOS.
 - SIGNS ON THE NORTH SIDE OF IRWIN SIMPSON ROAD ARE LOCATED PER AERIAL PHOTOS.

F:\Projects\688800\05_Deliverables\Drawings\114603\Design\Traffic\Sheets\114603TP000.dwg 19-Sep-23 3:52 PM

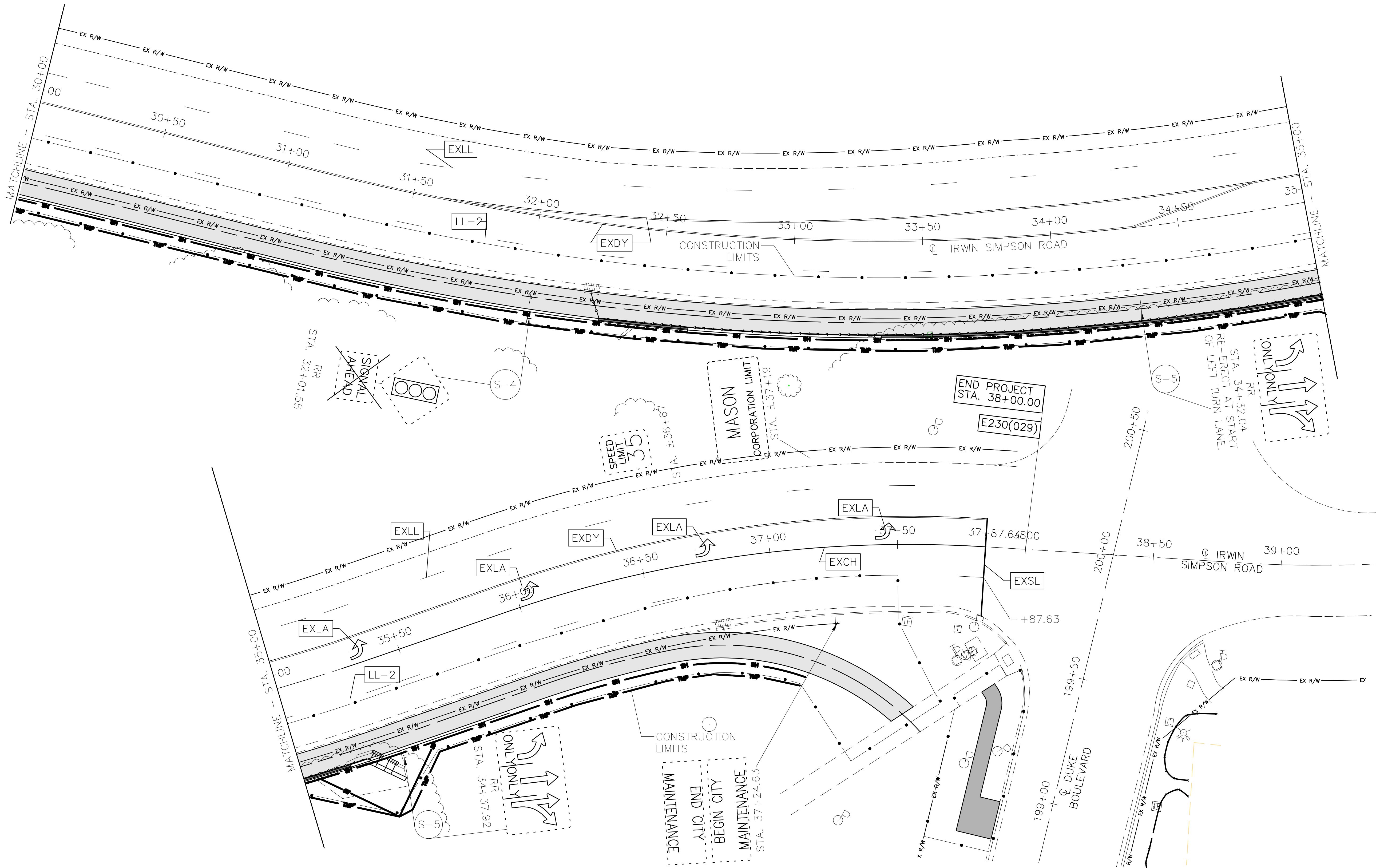

PAVEMENT MARKING LEGEND	
EL	EDGE LINE, 6" WHITE
CH	CHANNELIZING LINE, 6" WHITE
DY	CENTER LINE, SOLID DOUBLE YELLOW
DL	DOTTED LINE, 8" WHITE
WP	WORD ON PAVEMENT
LL	LANE LINE, 6" WHITE
SL	STOP LINE
XW	CROSS WALK
LA	LANE ARROW

(EX = EXISTING)

SIGN LEGEND	
	REMOVE SIGN
	EXISTING SIGN TO REMAIN
	PROPOSED SIGN
	EXISTING SIGN TO BE REMOVED AND RE-ERECTED ON NEW POST

NOTES

- EXISTING PAVEMENT MARKINGS FROM AERIAL PHOTOS.
- SIGNS ON THE NORTH SIDE OF IRWIN SIMPSON ROAD ARE LOCATED PER AERIAL PHOTOS.

CALCULATED
SCR
CHECKED
NW

0 10 20 40
HORIZONTAL
SCALE IN FEET

SIGN AND TRAFFIC PAVEMENT PLAN
STA. 30+00 TO STA. 39+00

WAR-TR55-2.11

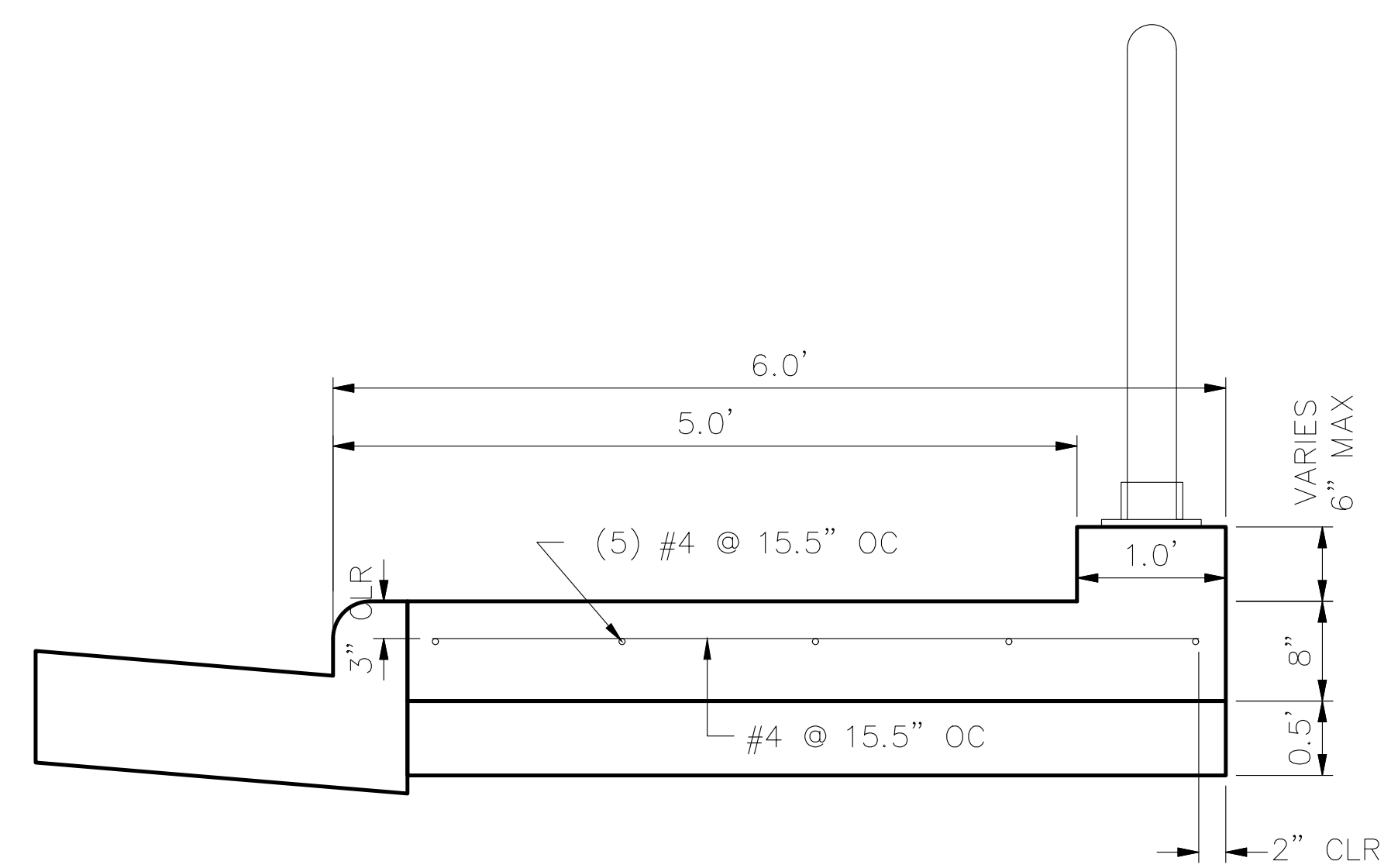

REINFORCED CURB RAMP WITHOUT TURNDOWN CURB
STA. 50+00.00 TO STA. 50+12.20

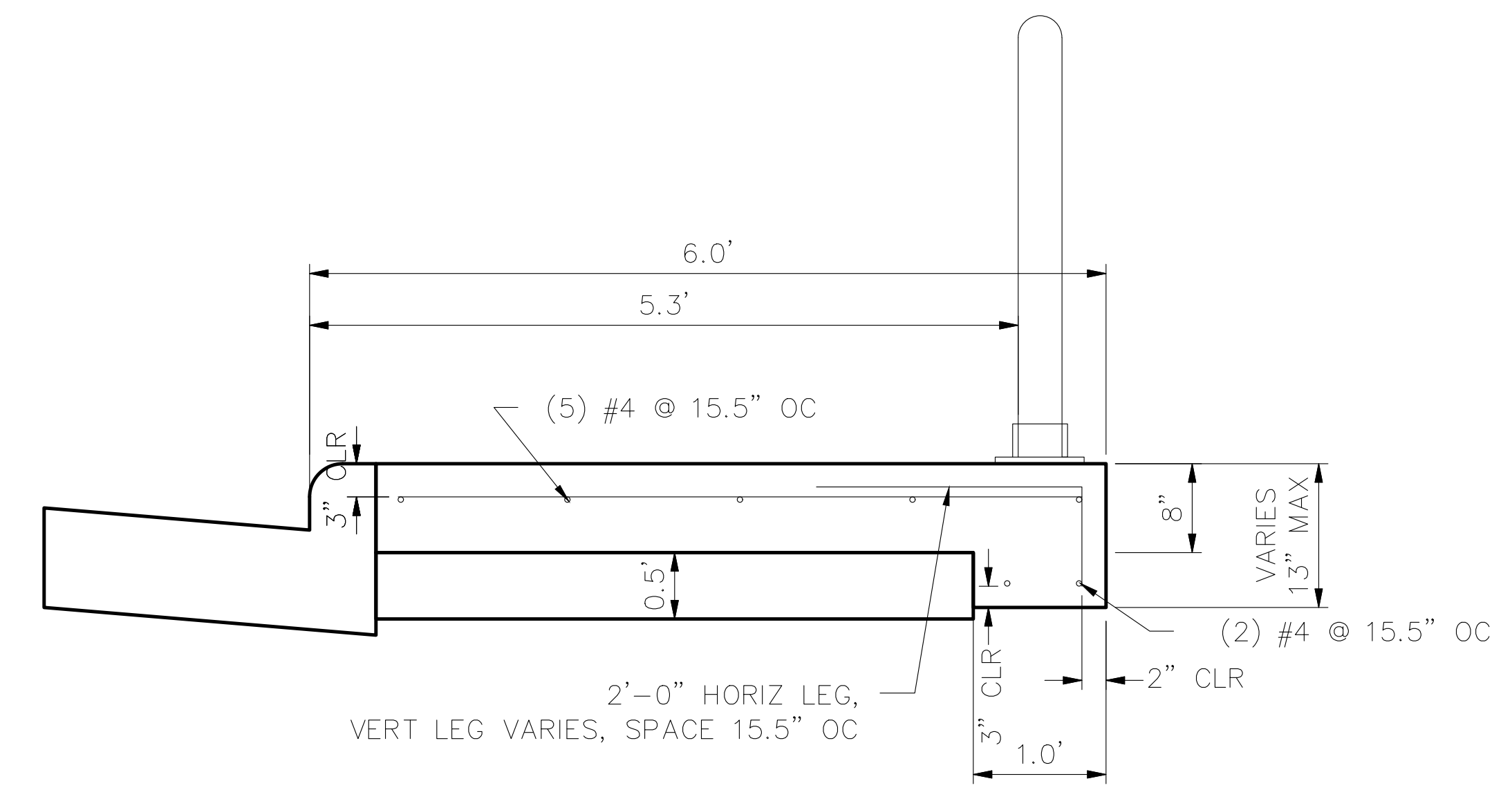

REINFORCED WALK WITH TURNDOWN CURB
STA. 50+17.84 TO STA. 50+22.34

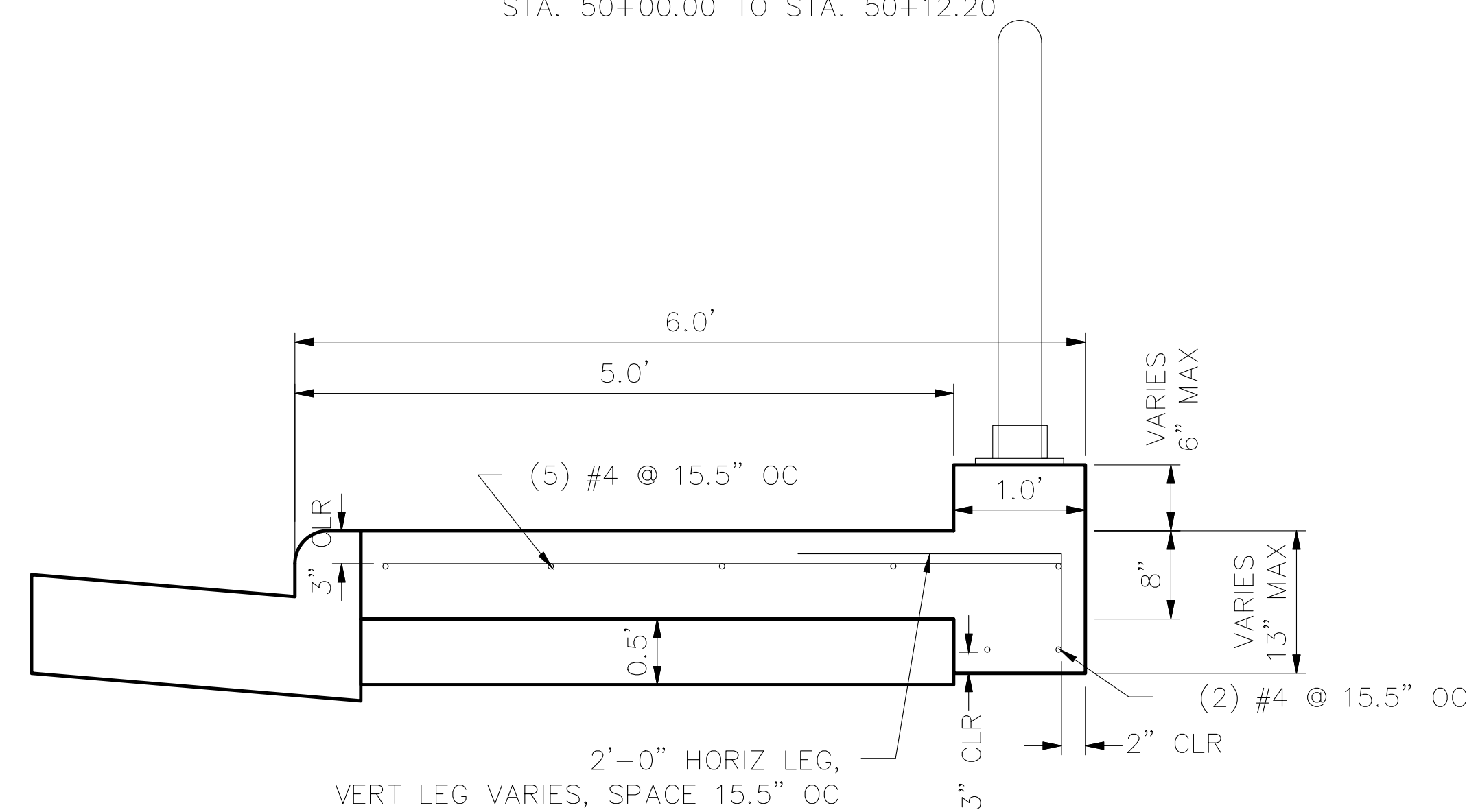

REINFORCED CURB RAMP WITH TURNDOWN CURB
STA. 50+12.20 TO STA. 50+17.84

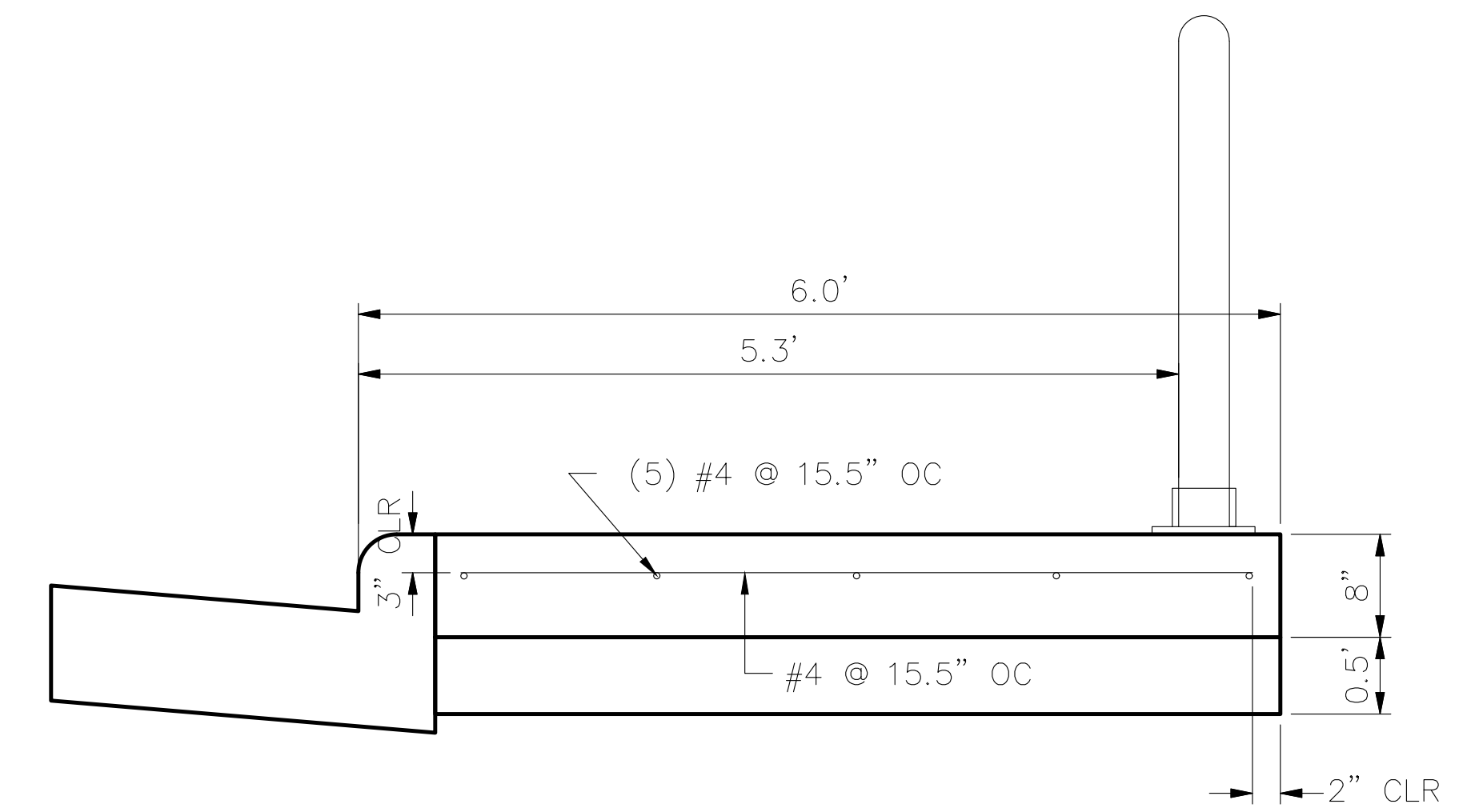

REINFORCED WALK WITHOUT TURNDOWN CURB
STA. 50+22.34 TO STA. 50+25.98

ITEM 608 - CURB RAMP, AS PER PLAN

THIS ITEM SHALL INCLUDE PROVIDING AND INSTALLING A TYPE B2 CURB RAMP USING REINFORCED CONCRETE AS DETAILED ON PLAN SHEETS 48 AND 49

THE REINFORCED CONCRETE SHALL BE PAID FOR UNDER ITEM 451 - 8" REINFORCED CONCRETE PAVEMENT CLASS QC 1P WITH QC/QA, AS PER PLAN AND ITEM 509 - EPOXY COATED REINFORCING STEEL.

ALL OTHER MATERIALS, LABOR AND EQUIPMENT TO PERFORM THIS WORK SHALL BE INCLUDED IN THE UNIT BID PRICE FOR ITEM 609 - CURB RAMP, AS PER PLAN

ITEM 451 - 8" REINFORCED CONCRETE PAVEMENT, CLASS QC 1P WITH QC/QA, AS PER PLAN

THIS ITEM SHALL INCLUDE PROVIDING AND INSTALLING AN 8" THICK REINFORCED CONCRETE SIDEWALK. TURNDOWN CURB WHERE REQUIRED SHALL BE MONOLITHICALLY POURED WITH THE 8" THICK REINFORCED CONCRETE PAVEMENT.

NEW CONCRETE SHALL NOT BE DOWELED INTO EXISTING HEADWALL. A 1/2" EXPANSION JOINT SHALL BE PROVIDED AT ALL LOCATIONS WHERE THE REINFORCED CONCRETE MEETS EXISTING PAVEMENT.

ALL MATERIALS, LABOR AND EQUIPMENT TO PERFORM THIS WORK SHALL BE INCLUDED IN THE UNIT BID PRICE FOR ITEM 451 - 8" REINFORCED CONCRETE PAVEMENT, CLASS QC 1P WITH QC/QA, AS PER PLAN

ESTIMATED QUANTITIES

ESTIMATED QUANTITIES					
ITEM	ITEM EXTENSION	TOTAL	UNIT	DESCRIPTION	SEE SHEET
451	13021	18	SY	8" REINFORCED CONCRETE PAVEMENT, CLASS QC1P WITH QC/QA, AS PER PLAN	
608	52001	108	SF	CURB RAMP, AS PER PLAN	
509	10000	216	POUNDS	EPOXY COATED REINFORCING STEEL	

F:\Projects\688800\05_Deliverables\Drawings\114603\Design\Roadway\Sheets\114603WD001.dwg 19-Sep-23 3:53 PM

B/W - BACK OF WALK
 F/C - FACE OF CURB
 T/C - TOP OF CURB

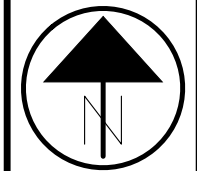

0 5 10
 2.5
 HORIZONTAL
 SCALE IN FEET

CALCULATED
 SCR
 CHECKED
 NW

REINFORCED CONCRETE SECTION
 PLAN AND PROFILE

WAR-TR55-2.11

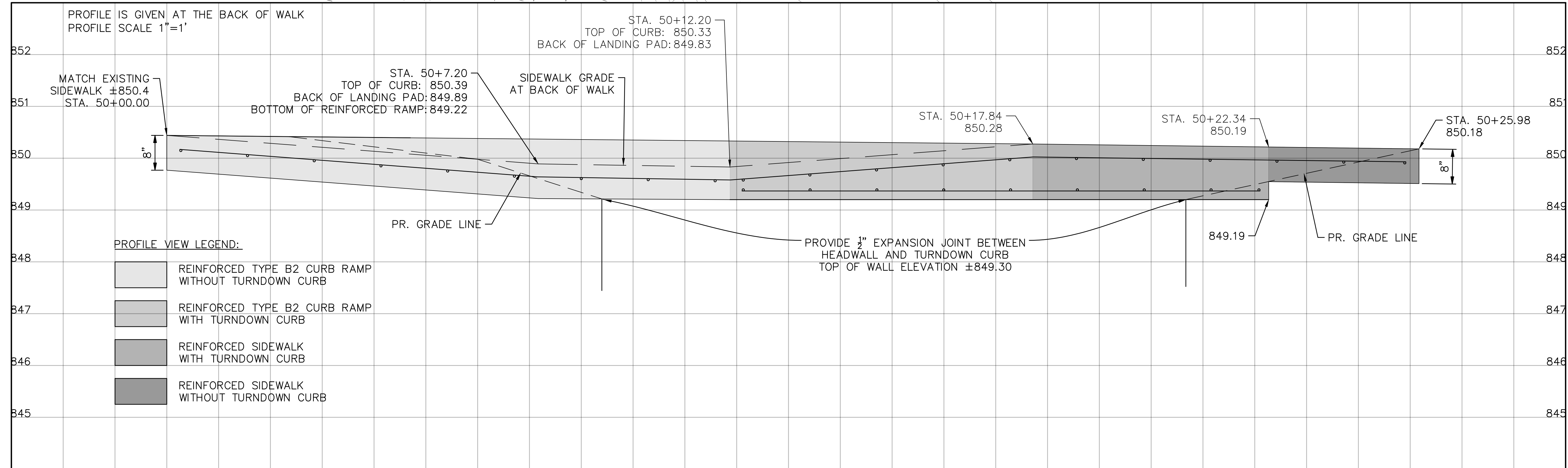
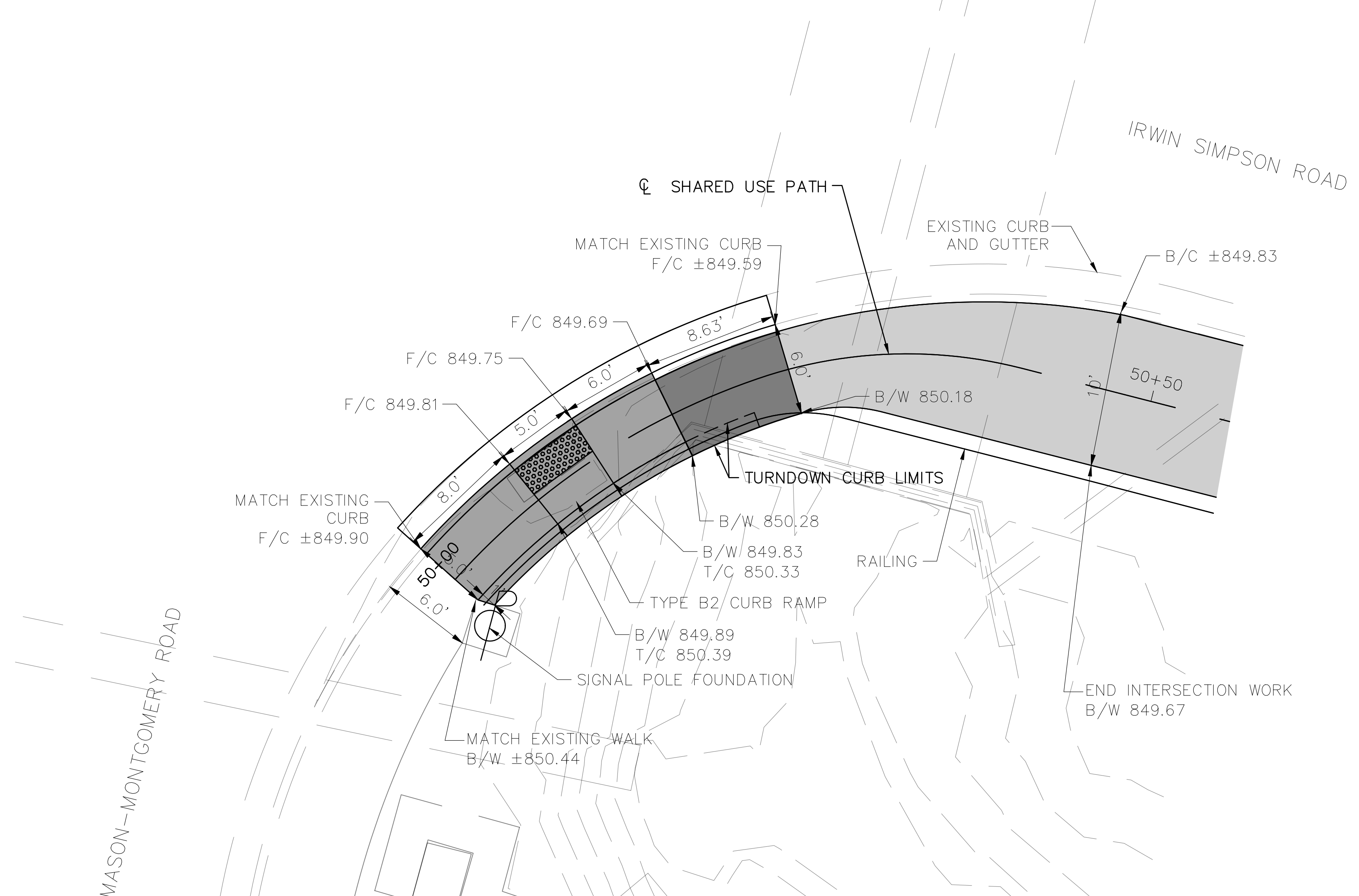

F:\Projects\688800\05_Deliverables\Drawings\114603\Roadway\Sheets\114603WP000.dwg 19-Sep-23 3:53 PM

ESTIMATED QUANTITIES

ESTIMATED QUANTITIES					
ITEM	ITEM EXTENSION	TOTAL	UNIT	DESCRIPTION	SEE SHEET
203	20000	255	CY	EMBANKMENT	
503	21100	343	CY	UNCLASSIFIED EXCAVATION	
511	46213	74	CY	CLASS QC1 CONCRETE WITH QC/QA, RETAINING/WINGWALL INCLUDING FOOTING, AS PER PLAN	
518	21201	42	CY	POROUS BACKFILL WITH GEOTEXTILE FABRIC	
509	10000	4973	POUNDS	EPOXY COATED REINFORCING STEEL	
605	06020	300	FT	4" BASE PIPE UNDERDRAINS WITH GEOTEXTILE FABRIC	
611	00410	20	FT	4" CONDUIT, TYPE F FOR UNDERDRAIN OUTLET	

SEAT WALL REINFORCING STEEL LIST

MARK	TOTAL	LENGTH	WEIGHT	TYPE	DIMENSIONS					
					A	B	C	D	E	R
RETAINING WALL										
S401	319	7'-4"	1562	1	1'-3"	6'-1"				
S402	84	30'0"	1684	STR						
S403	14	19'-0"	178	STR						
S404	313	3'-6"	732	STR						
S405	4	4'-6"	13	STR						
S406	4	26'-6"	71	STR						
S407	1	5'-0"	4	STR						
S408	1	11'-6"	8	2	2'-0"	1'-2"	5'-2"	1'-2"	2'-0"	
S409	14	7'-0"	66	STR						
S410	1	22'-6"	16	STR						
S411	219	3'-7"	525	3	2'-0"	1'-1"	0'-6"			
S501	2	4'-0"	9	STR						
S502	1	8'-0"	9	STR						
S601	2	7'-7"	23	1	1'-3"	6'-4"				
S602	6	8'-0"	73	1	1'-3"	6'-9"				
		TOTAL	4973							

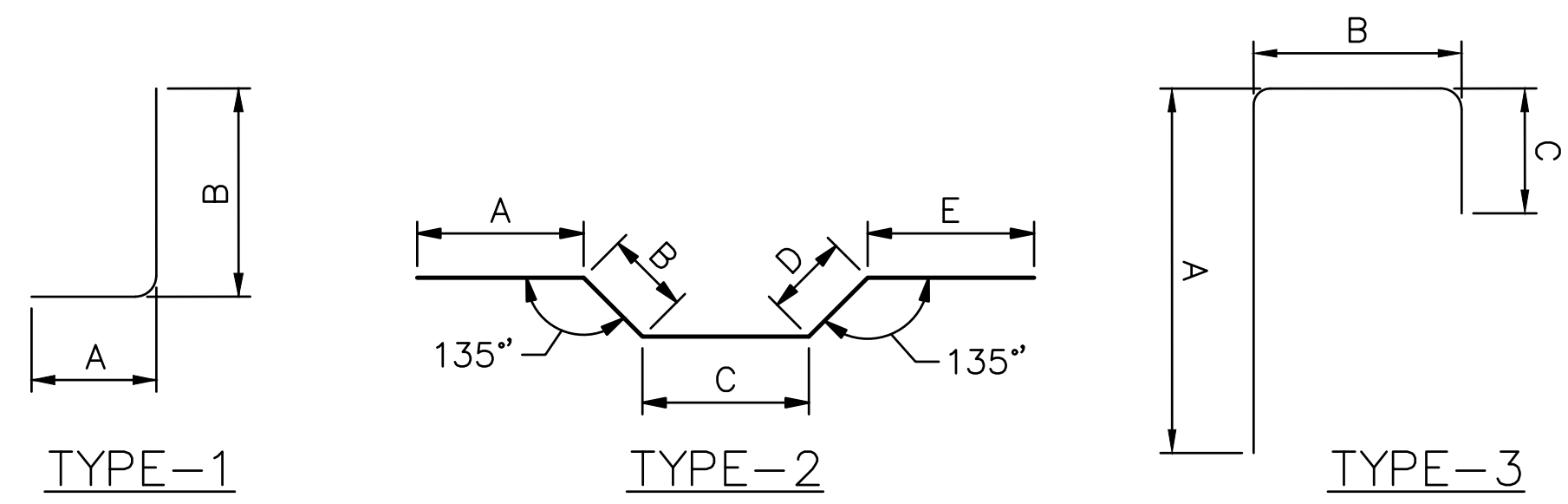

BENDING DIAGRAMS

ITEM 511 - CLASS QC1 CONCRETE WITH QC/QA, RETAINING/WINGWALL INCLUDING FOOTING, AS PER PLAN

THIS ITEM SHALL INCLUDE PROVIDING AND INSTALLING A RETAINING WALL.

ALL MATERIALS, LABOR AND EQUIPMENT TO PERFORM THIS WORK SHALL BE INCLUDED IN THE UNIT BID PRICE FOR ITEM 511 - CLASS QC1 CONCRETE WITH QC/QA, RETAINING/WINGWALL INCLUDING FOOTING, AS PER PLAN

PLACE MINIMUM ONE HALF OF THE INTERRUPTED BARS BUT NOT LESS THAN 1 - #6 EACH FACE (ALL SIDES) REINFORCING MAY BE SPREAD TO AVOID OPENING BUT THE SPACING OF BARS SHALL NOT EXCEED 3 TIMES WALL THICKNESS OR 18"

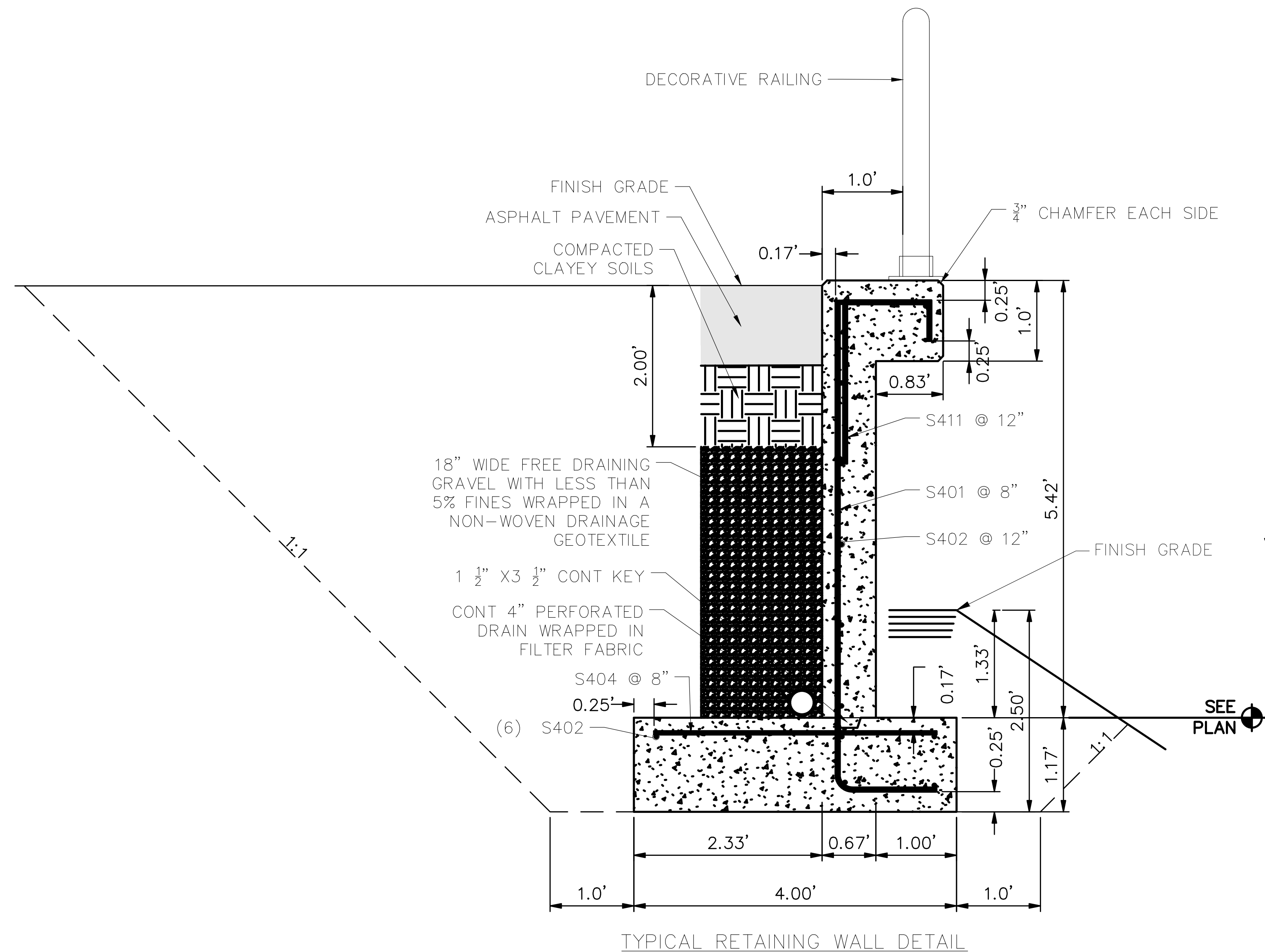

TYPICAL RETAINING WALL DETAIL

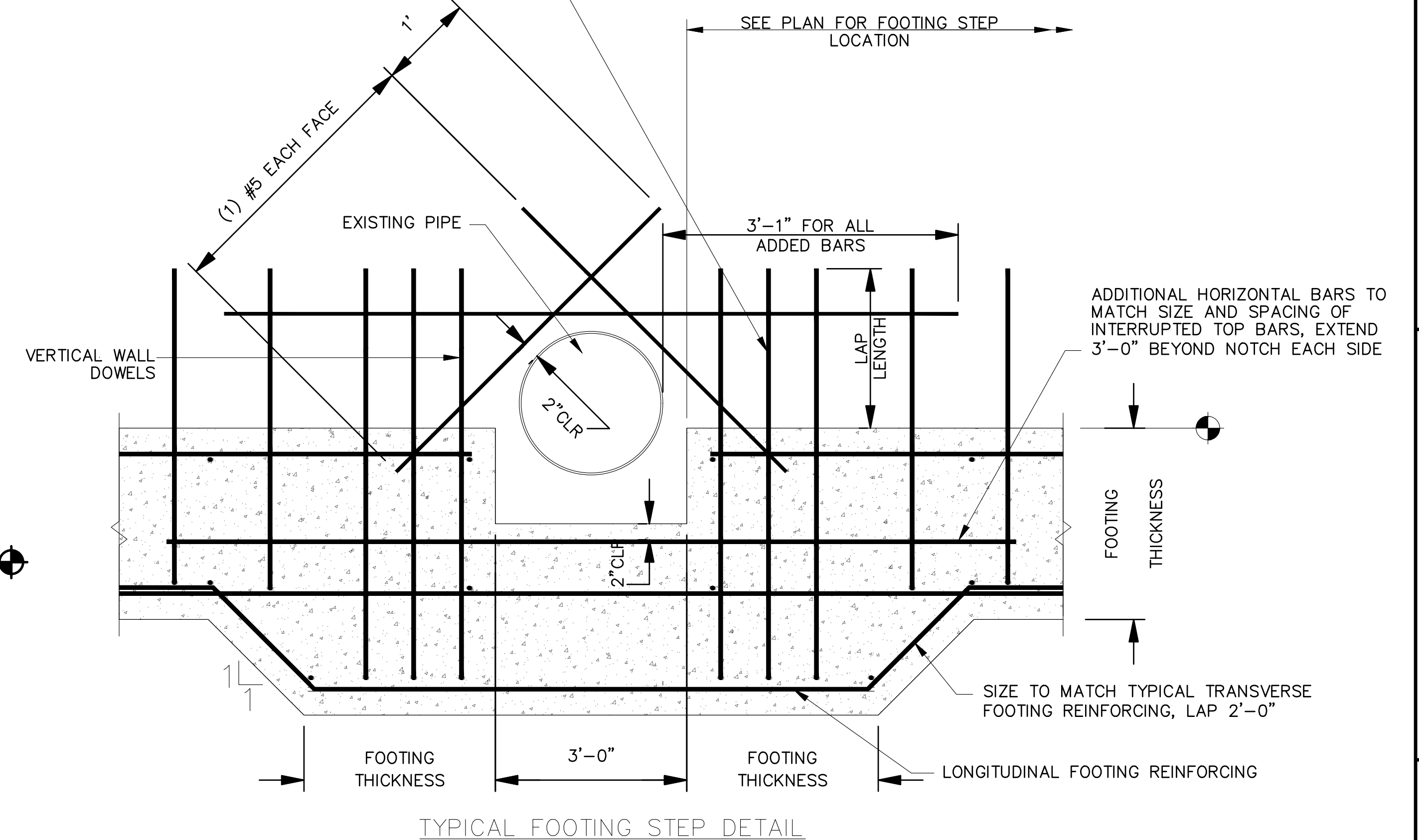

TYPICAL FOOTING STEP DETAIL

F:\Projects\688800\05_Deliverables\Drawings\114603\Design\Roadway\Sheets\114603WD001.dwg 19-Sep-23 3:53 PM

CALCULATED SCR CHECKED NW RETAINING WALL DETAIL SHEET

WAR-TR55-2.11

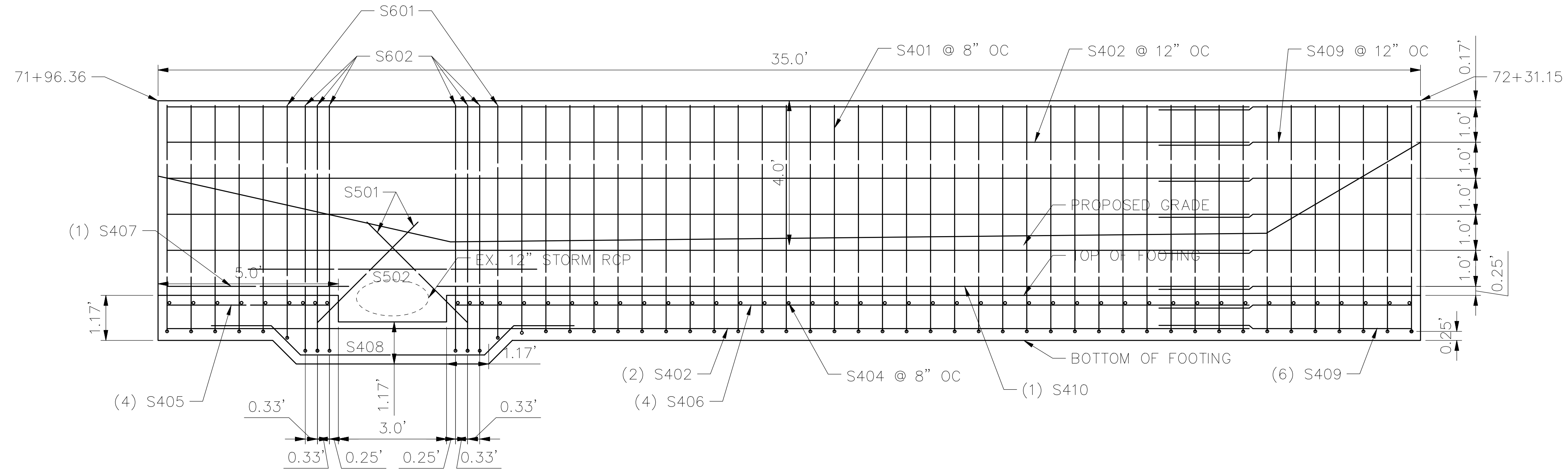

F:\Projects\688800\05_Deliverables\Drawings\114603\Design\Roadway\Sheets\114603WE001.dwg 19-Sep-23 3:53 PM

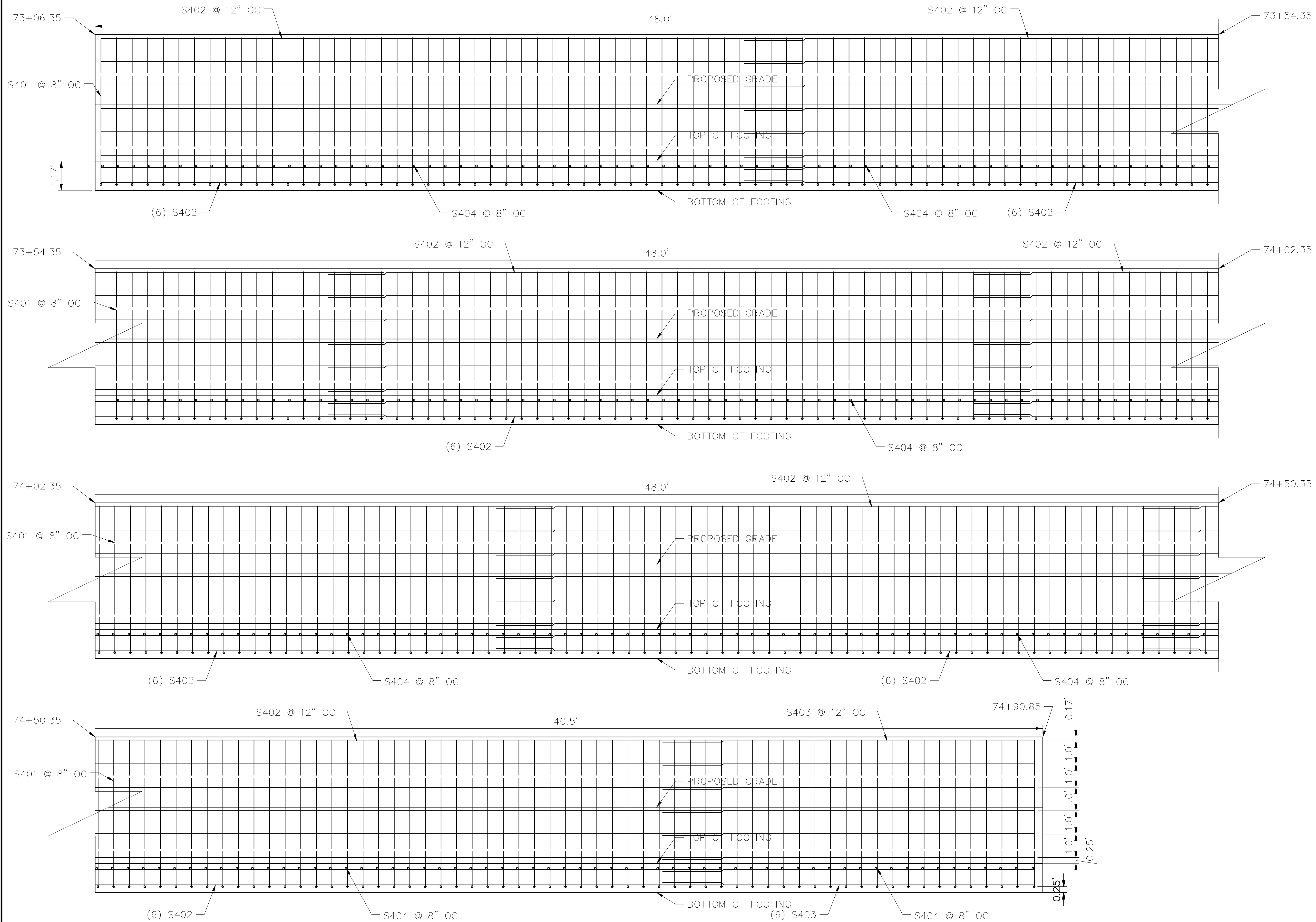

CALCULATED
SCR
CHECKED
NW

RETAINING WALL #2 ELEVATION SHEET

WAR-TR55-2.11

F:\Projects\688800\05_Deliverables\Drawings\114603\Design\Roadway\Sheets\114603WP000.dwg 19-Sep-23 3:54 PM

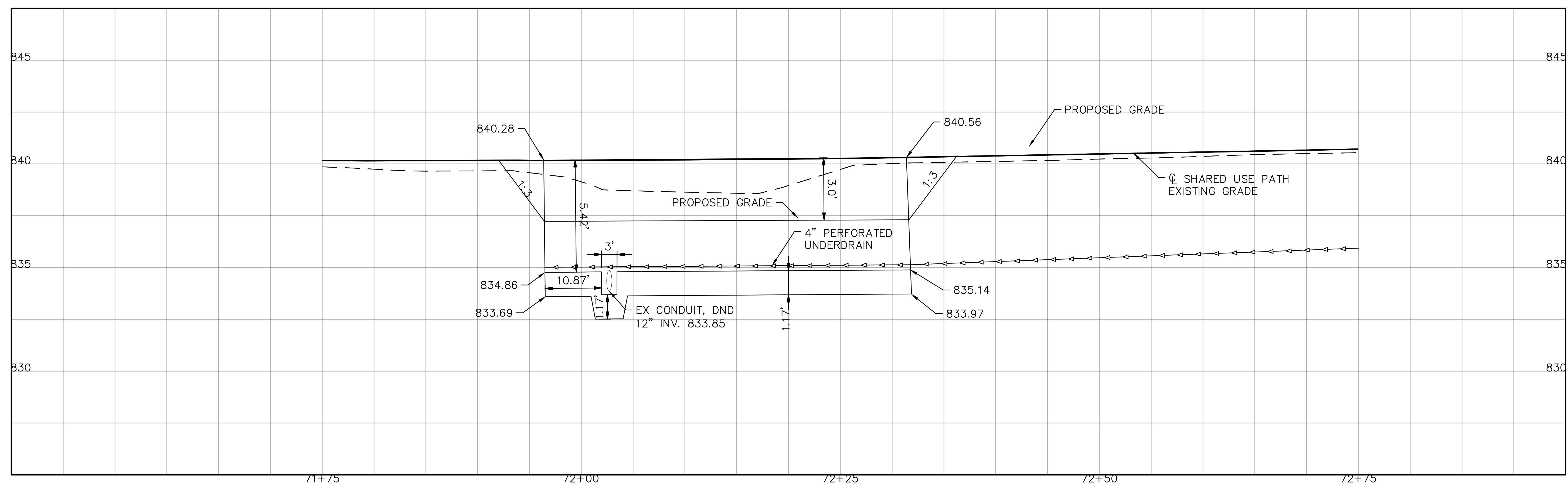
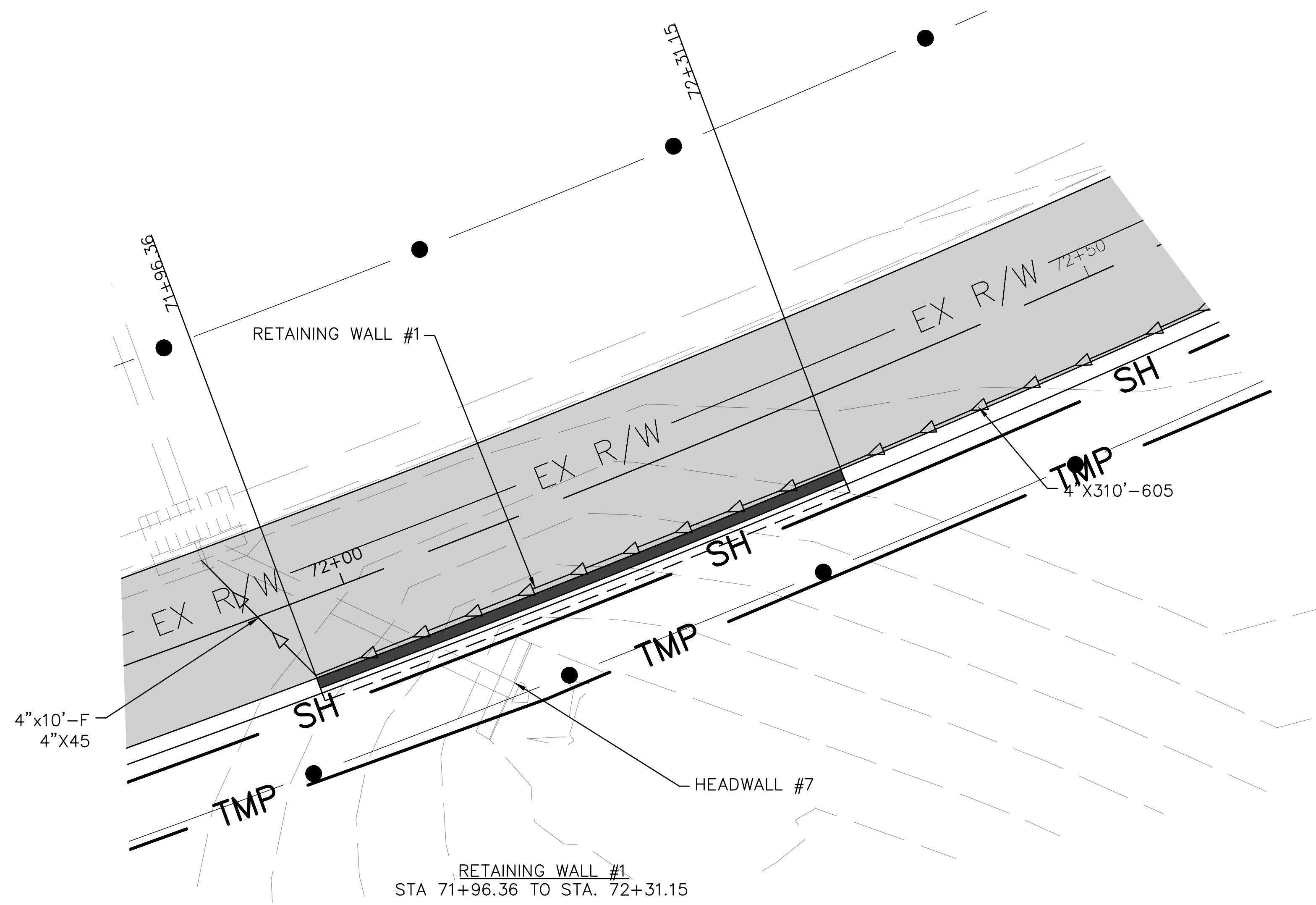

CALCULATED
SCR
CHECKED
NW

0 5 10
2.5
HORIZONTAL
SCALE IN FEET

RETAINING WALL PLAN AND PROFILE
STA, 71+96.36 TO STA. 72+31.15

WAR-TR55-2.11

F:\Projects\688800\05_Deliverables\Drawings\114603\Roadway\Sheets\114603WP000.dwg 19-Sep-23 3:54 PM

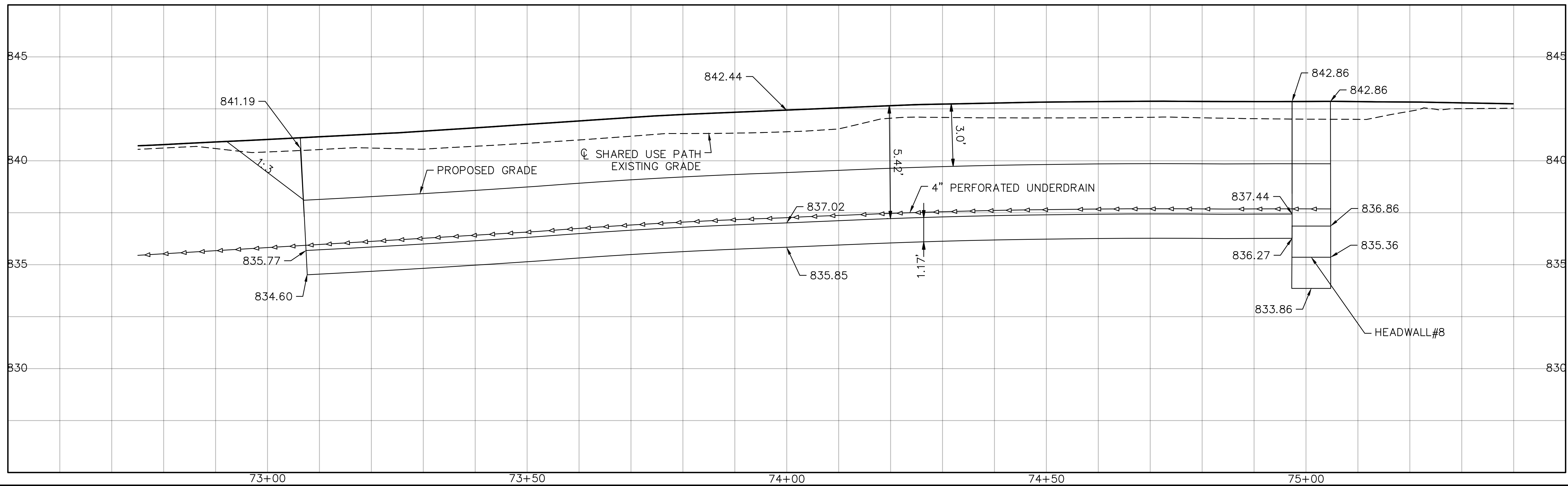
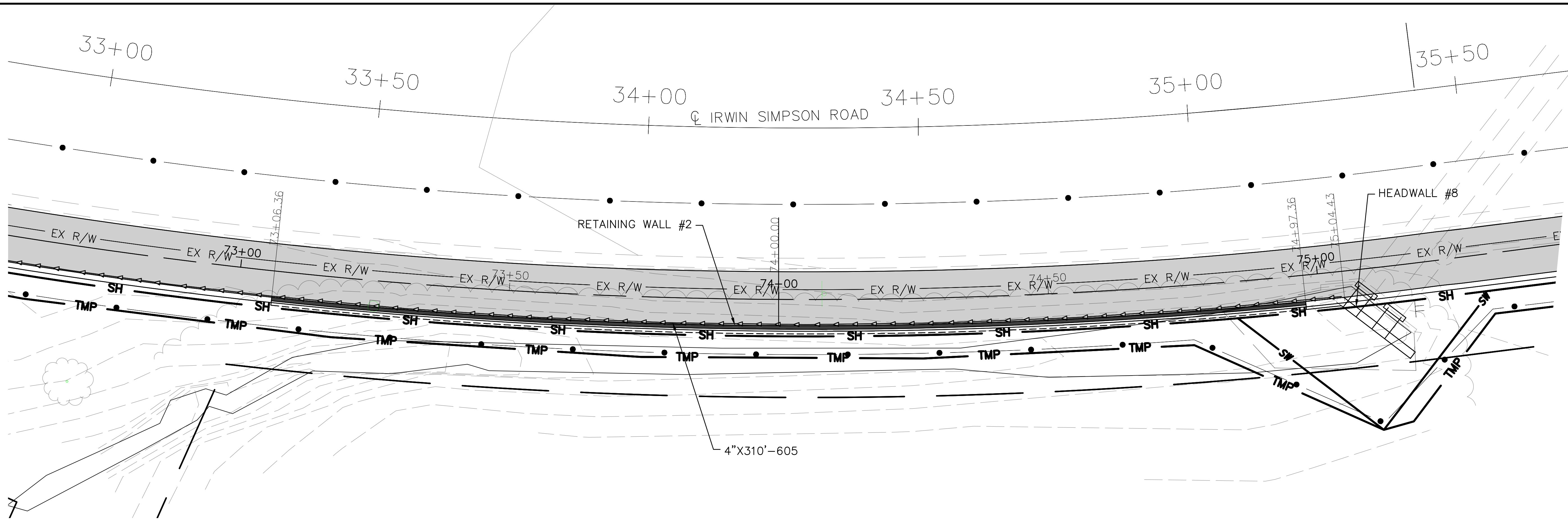

RETAINING WALL PLAN AND PROFILE
STA. 73+06.36 TO STA. 75+04.43

WAR-TR55-2.11

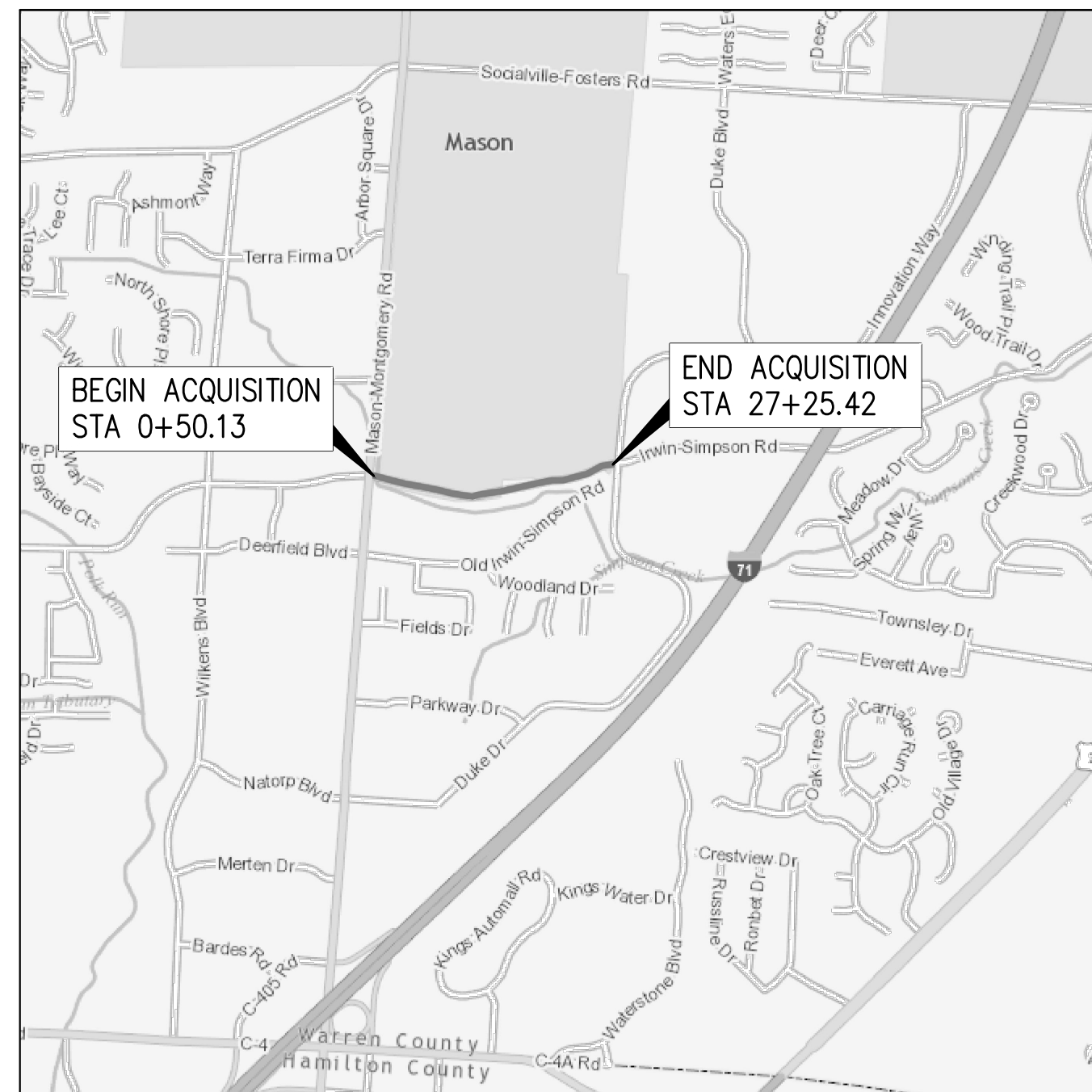

LOCATION MAP
Latitude: 39°18'35" Longitude: -84°18'48"

UNDERGROUND UTILITIES

**Contact Two Working Days
Before You Dig**

OHIO 811, 8-1-1, or 1-800-362-2764
Non-Members Must Be Called Directly

CONVENTIONAL SYMBOLS

	POWER POLE (EX)		TREELINE (EX)
	TRANSFORMER (EX)		CENTERLINE (EX)
	ELECTRIC METER (EX)		CORPORATION LINE (EX)
	ELECTRIC MANHOLE (EX)		RIGHT OF WAY (EX)
	TRAFFIC BOX (EX)		STANDARD HIGHWAY ESMT (EX)
	TRAFFIC POLE (EX)		STANDARD HIGHWAY ESMT (PR)
	TELEPHONE BOX (EX)		TEMPORARY RIGHT OF WAY (PR)
	CABLE BOX (EX)		SEWER EASEMENT (PR)
	FIRE HYDRANT (EX)		CONSTRUCTION LIMITS
	STORM MANHOLE (EX)		EDGE OF PAVEMENT (PR)
	MANHOLE (PR)		EDGE OF PAVEMENT (EX)
	CATCH BASIN (EX)		EDGE OF CURB (PR)
	DOUBLE GRATE INLET (EX)		EDGE OF CURB (EX)
	SINGLE GRATE INLET (EX)		OVERHEAD UTILITIES (EX)
	SANITARY MANHOLE (EX)		OUTLET UNDETERMINED (EX)
	CLEANOUT (EX)		STORM SEWER (PR)
	TREE (EX)		UNDERDRAIN (PR)
	SIGN 1 POST (PR)		STORM SEWER (EX)
	SIGN 2 POST (PR)		SANITARY SEWER (EX)
	WALL (PR)		RAILING (PR)
			CREEK (EX)

RIGHT OF WAY LEGEND SHEET WAR-TR55-2.11

WARREN COUNTY CITY OF MASON - DEERFIELD TOWNSHIP SECTION 27, TOWN 4, RANGE 2 BETWEEN THE MIAMIS

INDEX OF SHEETS:

LEGEND SHEET	1
CENTERLINE PLAT	2,3
PROPERTY MAP	4
SUMMARY OF ADDITIONAL R/W	5
R/W TOPOGRAPHIC SHEETS	6, 8, 10, 12, 14, 16
R/W BOUNDARY SHEETS	7, 9, 11, 13, 15, 17

UTILITIES

LISTED BELOW ARE ALL UTILITIES LOCATED WITHIN THE PROJECT CONSTRUCTION LIMITS TOGETHER WITH THEIR RESPECTIVE OWNERS:

AT&T (TELEPHONE)
2024 VALLEY ST
DAYTON, OH 45404
PH: 614-392-2873

WARREN CITY WATER & SEWER
406 JUSTICE DR
LEBANON, OH 45036
PH: 513-695-1377

DUKE ENERGY (GAS & ELECTRIC)
139 E 4TH ST
CINCINNATI, OH 45202
PH: 800-544-6900

ODOT DISTRICT 8
TRAFFIC DEPARTMENT
505 S. STATE ROUTE 741
LEBANON, OH 45036
PH: 513-933-6692

AT&T TRANSMISSION (F.O.)
525 VINE ST, ROOM 407
CINCINNATI, OH 45202
SCOTT MERGLER
PH: 513-277-4655

CHARTER COMMUNICATION (F.O.)
SPECTRUM/TIME WARNER/USIC
11252 CORNELL PARK DRIVE
OHIO 45242-1886
PH: 513-469-5483

CINCINNATI BELL (F.O.) USIC
201 E 4TH ST
ML 103-1175
CINCINNATI, OH 45202
PH: 513-565-7043

CTLCL - CENTURYLINK (F.O) USIC
205 W 4TH ST
CINCINNATI, OH 45202
JOSH MOTZER
PH: 513-241-6719

NOTES: THE LOCATION OF THE UNDERGROUND UTILITIES SHOWN ON THE PLANS ARE OBTAINED FROM THE OWNER OF THE UTILITIES AS REQUIRED BY SECTION 153.64 O.R.C.

PROJECT DESCRIPTION:
CONSTRUCT SHARED USE TRAIL ALONG IRWIN-SIMPSON FROM MASON-MONTGOMERY ROAD TO THE EXISTING TRAIL JUST WEST OF DUKE BOULEVARD

THE EXISTING AND PROPOSED RIGHT OF WAY SHALL BE REFERENCED FROM THE CENTERLINE OF RIGHT OF WAY OF IRWIN-SIMPSON ROAD.

BASIS FOR BEARINGS
ALL BEARINGS SHOWN ARE FOR PROJECT USE ONLY. THE BASIS OF BEARINGS FOR THIS PROJECT IS BASED UPON OHIO STATE PLANE COORDINATE SYSTEM, SOUTH ZONE NAD 83 (11) UTILIZING ODOT VRS SURVEY SYSTEM AND PROCEDURES.

PLANS PREPARED BY:

FIRM NAME : BERDING SURVEYING
R/W DESIGNER: TIM SCHWOEPEPE
R/W REVIEWER: GERRY BERDING
FIELD REVIEWER: JOHN COOK
PRELIMINARY FIELD REVIEW DATE: 9/7/21
TRACINGS FIELD REVIEW DATE: _____
OWNERSHIP UPDATED BY: TIM SCHWOEPEPE
DATE COMPLETED: 6/1/23
PLAN COMPLETION DATE: _____

TYPES OF TITLE LEGEND:

SH = STANDARD HIGHWAY EASEMENT
T = TEMPORARY EASEMENT
SW = SEWER EASEMENT

STRUCTURE KEY

COMMERCIAL

I, GERARD J. BERDING, P. S. have conducted a survey of the existing conditions for the Ohio Department of Transportation in September 2021. The results of that survey are contained herein. The horizontal coordinates expressed herein are based on the Ohio State Plane Coordinates System, South Zone on NAD 83 (11). The Project Coordinates (US Survey Feet) are relative to State Plane Grid Coordinates (US Survey Feet) by a Project Adjustment Factor of 1.000098839226. As a part of this project I have reestablished the locations of the existing property lines and the existing centerline of Right of Way for property takes contained herein. As a part of this project I have established the proposed property lines, calculated the Gross Take, present roadway occupied (PRO), Net Take and Net Residue; as well as prepared the legal descriptions necessary to acquire the parcels as shown herein. As a part of this work I have set right of way monuments at the property corners, property line intersection, points along the right of way and/or angle points on the right of way, Section Corners and other points as shown herein. All of my work contained herein was conducted in accordance with Ohio Administrative Code 4733-37 commonly known as "Minimum Standards for Boundary Surveys in the State of Ohio" unless noted. The words I and my as used herein are to mean either myself or someone working under my direct supervision.

Gerard J. Berding
Gerard J. Berding, P.S. 6880

6-1-2023
Date:

SURVEYORS SEAL

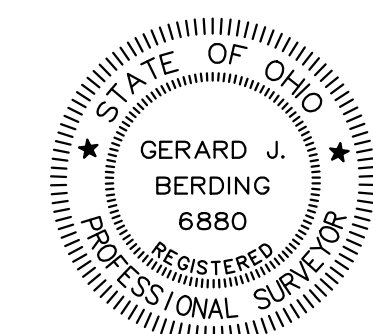

WAR-TR55-2.11

WARREN COUNTY
CITY OF MASON - DEERFIELD TOWNSHIP
SECTION 27, TOWN 4, RANGE 2
BETWEEN THE MIAMIS

RECEIVED _____, 20____
RECORDED _____, 20____
BOOK _____ PAGE _____
COUNTY RECORDER



0 100 200
HORIZONTAL SCALE IN FEET

PID NO.
114603

R/W DESIGNER TMS
R/W REVIEWER GJB

CENTERLINE PLAT

WAR-TR55-2.11

2 / 17

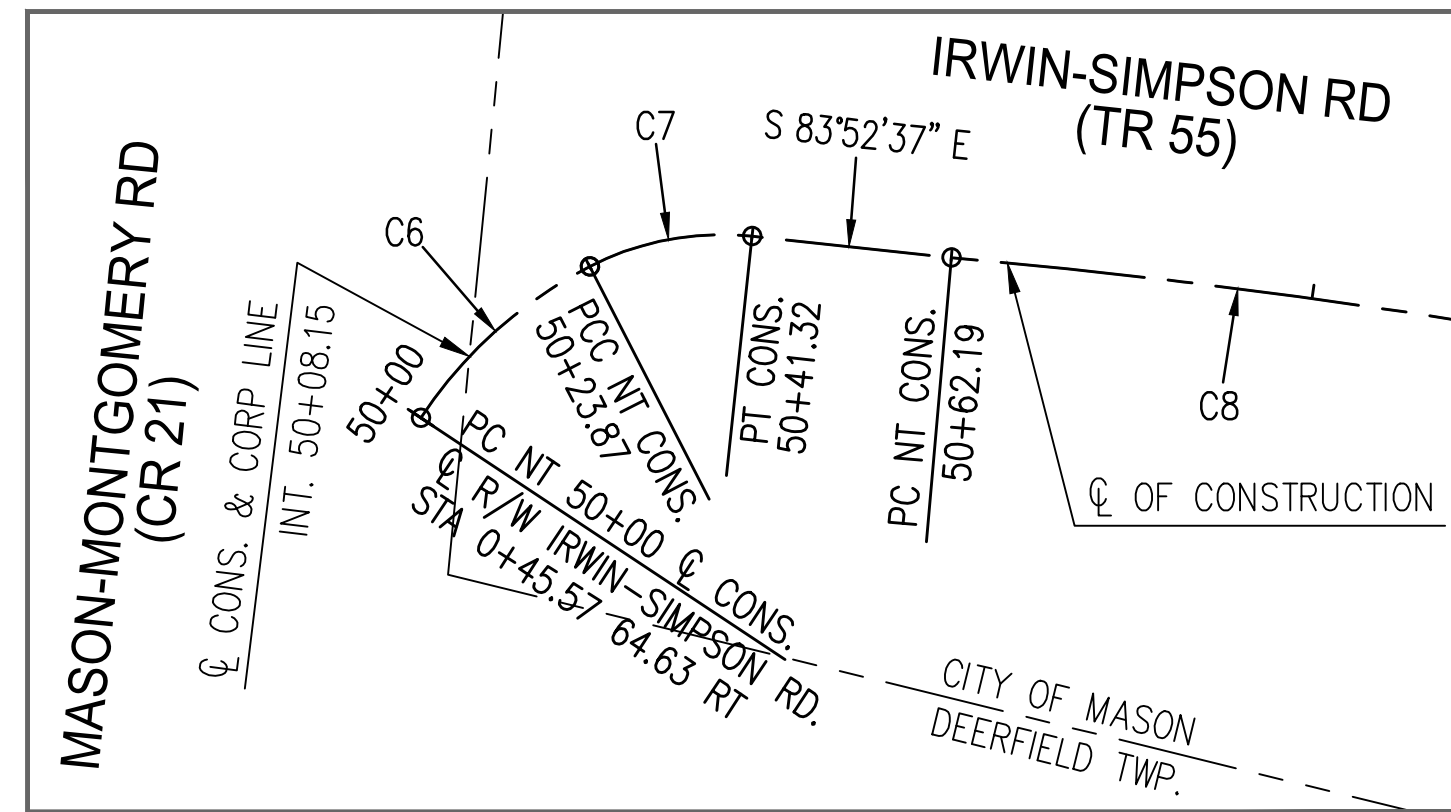

DETAIL A - NOT TO SCALE

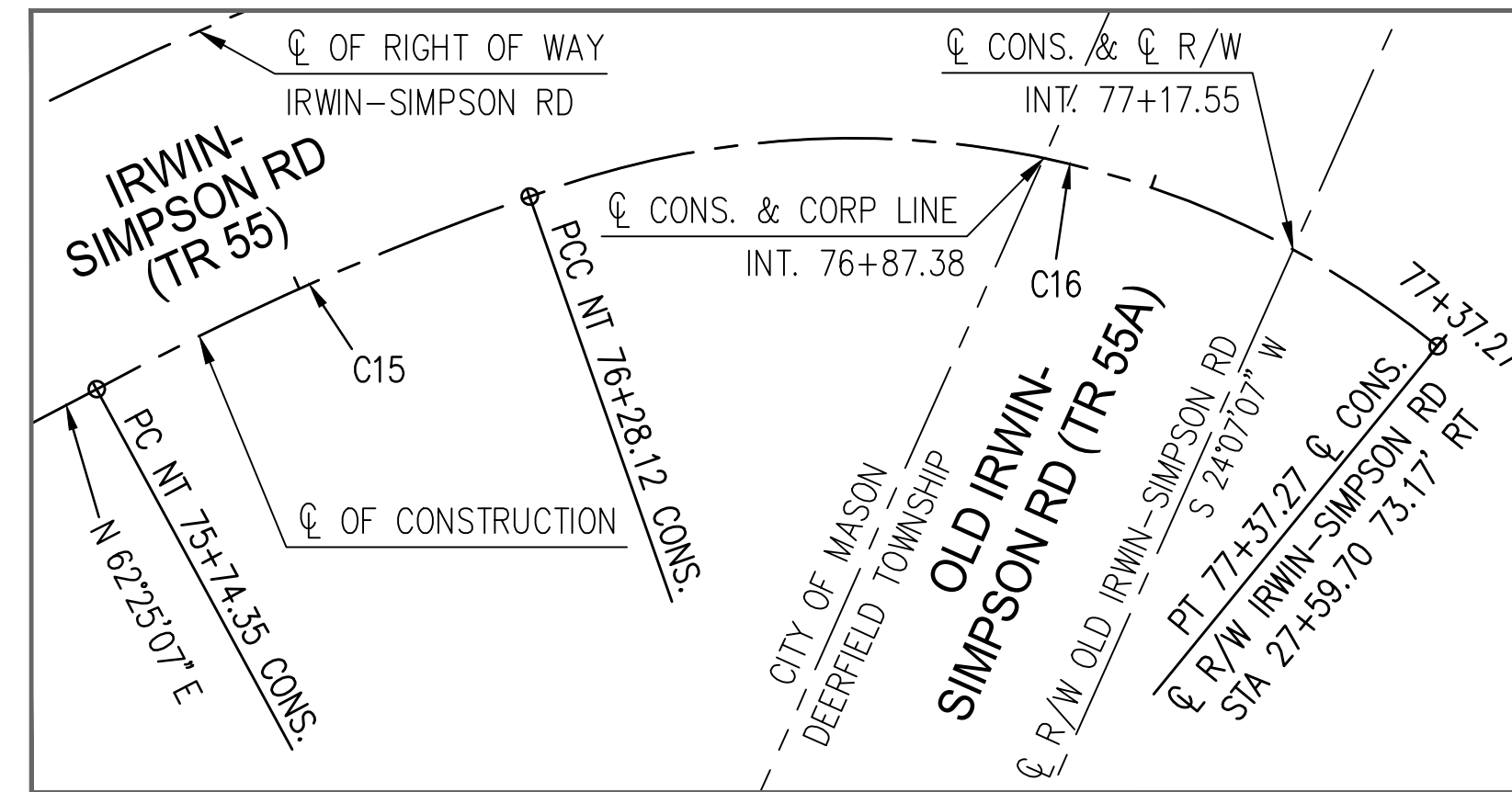

DETAIL B - NOT TO SCALE

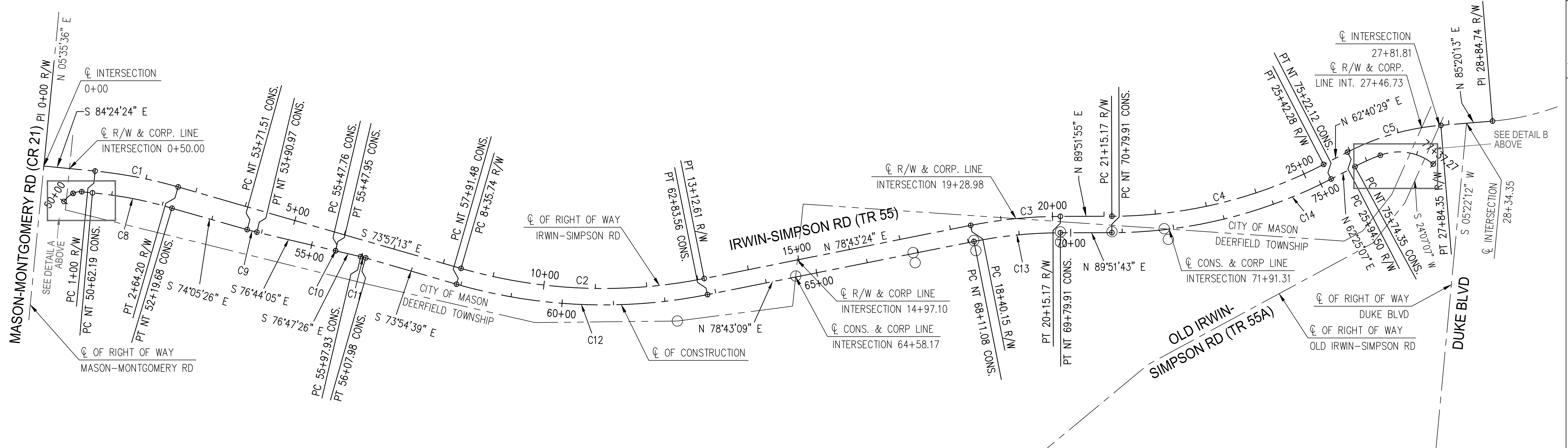

SEE SHEET 3 FOR CURVE ANNOTATIONS

PROJECT CONTROL

THE PROJECT CONTROL FOR THIS PROJECT CONFORMS AND IS BASED UPON OHIO STATE PLANE COORDINATE SYSTEM, SOUTH ZONE NAD 83 (11). THE GRID TO GROUND SCALE FACTOR = 1.000098839226; SCALED FROM 1455382.08 (X), 482359.15 (Y).

BASIS FOR BEARINGS:

ALL BEARINGS SHOWN ARE FOR PROJECT USE ONLY. THE BASIS OF BEARINGS FOR THIS PROJECT IS BASED UPON OHIO STATE PLANE COORDINATE SYSTEM, SOUTH ZONE NAD 83 (11).

THE EXISTING AND PROPOSED RIGHT OF WAY SHALL BE REFERENCED FROM THE CENTERLINE OF RIGHT OF WAY OF IRWIN-SIMPSON ROAD.

THE EXISTING R/W WIDTH AND LOCATION WERE DETERMINED USING DEDICATION PLAT FOR IRWIN-SIMPSON ROAD RELOCATION AS RECORDED IN PLAT BOOK 39, PAGE 3 OF WARREN COUNTY RECORDER'S OFFICE.

I, GERARD J. BERDING, P. S. have conducted a survey of the existing conditions for the Hamilton County Engineers Office in September 2021. The results of that survey are contained herein. The horizontal coordinates expressed herein are based on the Ohio State Plane Coordinates System, South Zone on NAD 83 (11). The Project Coordinates (US Survey Feet) are relative to State Plane Grid Coordinates (US Survey Feet) by a Project Adjustment Factor of 1.000098839226. As a part of this project I have reestablished the locations of the existing property lines and the existing centerline of Right of Way for property takes contained herein. As a part of this project I have established the proposed property lines, calculated the Gross Take, present roadway occupied (PRO), Net Take and Net Residue; as well as prepared the legal descriptions necessary to acquire the parcels as shown herein. As a part of this work I have set right of way monuments at the property corners, property line intersection, points along the right of way and/or angle points on the right of way, Section Corners and other points as shown herein. All of my work contained herein was conducted in accordance with Ohio Administrative Code 4733-37 commonly known as "Minimum Standards for Boundary Surveys in the State of Ohio" unless noted. The words I and my as used herein are to mean either myself or someone working under my direct supervision.

○ INDICATES EXISTING IRON PIN AND CAP
MONUMENT LEGEND

Gerard J. Berding
Gerard J. Berding, P.S. 6880 Date: 6-1-2023

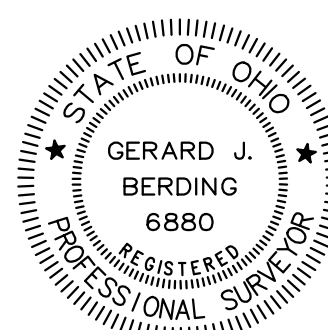

EXISTING MONUMENT TABLE					
☐ of RIGHT OF WAY IRWIN-SIMPSON ROAD		PROJECT COORDINATES SEE SURVEY CERTIFICATION		EXPECTED TO BE DISTURBED	MONUMENT TYPE & DESCRIPTION
STATION	OFFSET	NORTH (Y)	EAST (X)		
12+49.78	72.69' RT	482021.48	1456556.97		IPC (HENDERSON BODWELL)
14+87.82	30.00' RT	482108.70	1456786.92	X	IPC (BAUMANN 7450)
17+20.07	30.00' RT	482154.11	1457014.68	X	IPC (BAUMANN 7450)
17+20.16	50.04' RT	482134.48	1457018.69		IPC (BAUMANN 7450)
18+40.25	49.99' RT	482158.01	1457136.44		IPC (BAUMANN 7450)
18+40.26	30.03' RT	482177.59	1457132.55	X	IPC (BAUMANN 7450)
20+15.28	49.94' RT	482174.45	1457300.68		IPC (BAUMANN 7450)
20+15.29	30.13' RT	482194.26	1457300.64	X	IPC (BAUMANN 7450)
21+15.29	29.99' RT	482194.63	1457400.65	X	IPC (BAUMANN 7450)
22+13.51	30.00' RT	482200.41	1457501.93	X	IPC (BAUMANN 7450)
22+19.00	51.41' RT	482179.79	1457510.08		IPC (BAUMANN 7450)
				6	

WAR-TR55-2.11

WARREN COUNTY
CITY OF MASON - DEEFIELD TOWNSHIP
SECTION 27, TOWN 4, RANGE 2
BETWEEN THE MIAMIS

RECEIVED _____, 20____
RECORDED _____, 20____
BOOK _____ PAGE _____
COUNTY RECORDER

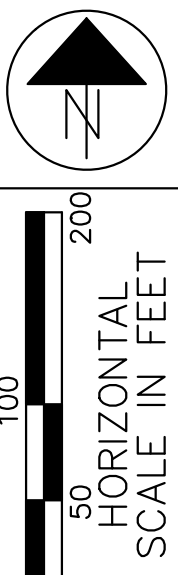

<p>C1 \curvearrowright R/W PI STA 1+82.33 $\Delta = 10^{\circ}27'11''$ (RT) DC = 06'21'58" R = 900.00' T = 82.33' L = 164.20' E = 3.76' CH = 163.97' CH BRG = S 79'10'49" E</p>	<p>C2 \curvearrowright R/W PI STA 10+78.80 $\Delta = 27^{\circ}19'23''$ (LT) DC = 05'43'46" R = 1000.00' T = 243.06' L = 476.88' E = 29.12' CH = 472.37' CH BRG = S 87'36'55" E</p>	<p>C3 \curvearrowright R/W PI STA 19+27.94 $\Delta = 11^{\circ}08'31''$ (RT) DC = 06'21'58" R = 900.00' T = 87.79' L = 175.02' E = 4.27' CH = 174.74' CH BRG = N 84'17'39" E</p>	<p>C4 \curvearrowright R/W PI STA 23+32.83 $\Delta = 27^{\circ}11'26''$ (LT) DC = 06'21'58" R = 900.00' T = 217.65' L = 427.11' E = 25.94' CH = 423.11' CH BRG = N 76'16'12" E</p>	<p>C5 \curvearrowright R/W PI STA 26+90.68 $\Delta = 22^{\circ}39'44''$ (RT) DC = 11'56'12" R = 480.00' T = 96.18' L = 189.85' E = 9.54' CH = 188.62' CH BRG = N 74'00'21" E</p>	<p>C6 \curvearrowright CONSTRUCTION PI STA 50+12.20 $\Delta = 29^{\circ}16'50''$ (RT) DC = 122'38'31" R = 46.72' T = 12.20' L = 23.87' E = 1.57' CH = 23.62' CH BRG = N 48'10'23" E</p>	<p>C7 \curvearrowright CONSTRUCTION PI STA 50+32.85 $\Delta = 33^{\circ}18'32''$ (RT) DC = 190'59'09" R = 30.00' T = 8.97' L = 17.44' E = 1.31' CH = 17.20' CH BRG = N 79'28'07" E</p>	<p>C8 \curvearrowright CONSTRUCTION PI STA 51+41.21 $\Delta = 11^{\circ}43'03''$ (RT) DC = 07'26'24" R = 770.09' T = 79.02' L = 157.49' E = 4.04' CH = 157.22' CH BRG = S 79'06'16" E</p>
<p>C9 \curvearrowright CONSTRUCTION PI STA 53+81.24 $\Delta = 02^{\circ}09'27''$ (LT) DC = 11'04'56" R = 517.01' T = 9.74' L = 19.47' E = 0.09' CH = 19.47' CH BRG = S 75'32'33" E</p>	<p>C10 \curvearrowright CONSTRUCTION PI STA 55+47.85 $\Delta = 00^{\circ}03'21''$ (LT) DC = 28'38'53" R = 200.00' T = 0.10' L = 0.20' E = 0.00' CH = 0.20' CH BRG = S 76'45'46" E</p>	<p>C11 \curvearrowright CONSTRUCTION PI STA 56+02.95 $\Delta = 02^{\circ}52'47''$ (RT) DC = 28'38'52" R = 200.00' T = 5.03' L = 10.05' E = 0.06' CH = 10.05' CH BRG = S 75'21'03" E</p>	<p>C12 \curvearrowright CONSTRUCTION PI STA 60+42.29 $\Delta = 27^{\circ}19'08''$ (LT) DC = 05'33'06" R = 1032.03' T = 250.81' L = 492.08' E = 30.04' CH = 487.43' CH BRG = S 87'37'17" E</p>	<p>C13 \curvearrowright CONSTRUCTION PI STA 68+95.76 $\Delta = 11^{\circ}06'14''$ (RT) DC = 06'34'37" R = 871.16' T = 84.68' L = 168.83' E = 4.11' CH = 168.57' CH BRG = N 84'18'41" E</p>	<p>C14 \curvearrowright CONSTRUCTION PI STA 73+05.26 $\Delta = 27^{\circ}10'33''$ (LT) DC = 06'08'44" R = 932.33' T = 225.35' L = 442.21' E = 26.85' CH = 438.08' CH BRG = N 76'16'20" E</p>	<p>C15 \curvearrowright CONSTRUCTION PI STA 76+01.29 $\Delta = 09^{\circ}10'27''$ (RT) DC = 17'03'45" R = 335.80' T = 26.94' L = 53.77' E = 1.08' CH = 53.71' CH BRG = N 66'02'00" E</p>	<p>C16 \curvearrowright CONSTRUCTION PI STA 76+88.24 $\Delta = 59^{\circ}43'55''$ (RT) DC = 54'43'23" R = 104.70' T = 60.12' L = 109.15' E = 16.03' CH = 104.28' CH BRG = S 80'39'16" E</p>

PROJECT CONTROL

THE PROJECT CONTROL FOR THIS PROJECT CONFORMS AND IS BASED UPON OHIO STATE PLANE COORDINATE SYSTEM, SOUTH ZONE NAD 83 (11). THE GRID TO GROUND SCALE FACTOR = 1.0000988392226; SCALED FROM 1455382.08 (X), 482359.15 (Y).

BASIS FOR BEARINGS:

ALL BEARINGS SHOWN ARE FOR PROJECT USE ONLY. THE BASIS OF BEARINGS FOR THIS PROJECT IS BASED UPON OHIO STATE PLANE COORDINATE SYSTEM, SOUTH ZONE NAD 83 (11).

THE EXISTING AND PROPOSED RIGHT OF WAY SHALL BE REFERENCED FROM THE CENTERLINE OF RIGHT OF WAY OF IRWIN-SIMPSON ROAD.

THE EXISTING R/W WIDTH AND LOCATION WERE DETERMINED USING DEDICATION PLAT FOR IRWIN-SIMPSON ROAD RELOACTION AS RECORDED IN PLAT BOOK 39, PAGE 3 OF WARREN COUNTY RECORDER'S OFFICE.

I, GERARD J. BERDING, P. S. have conducted a survey of the existing conditions for the Hamilton County Engineers Office in September 2021. The results of that survey are contained herein. The horizontal coordinates expressed herein are based on the Ohio State Plane Coordinates System, South Zone on NAD 83 (11). The Project Coordinates (US Survey Feet) are relative to State Plane Grid Coordinates (US Survey Feet) by a Project Adjustment Factor of 1.0000988392226. As a part of this project I have reestablished the locations of the existing property lines and the existing centerline of Right of Way for property takes contained herein. As a part of this project I have established the proposed property lines, calculated the Gross Take, present roadway occupied (PRO), Net Take and Net Residue; as well as prepared the legal descriptions necessary to acquire the parcels as shown herein. As a part of this work I have set right of way monuments at the property corners, property line intersection, points along the right of way and/or angle points on the right of way, Section Corners and other points as shown herein. All of my work contained herein was conducted in accordance with Ohio Administrative Code 4733-37 commonly known as "Minimum Standards for Boundary Surveys in the State of Ohio" unless noted. The words I and my as used herein are to mean either myself or someone working under my direct supervision.

Gerard J. Berding
Gerard J. Berding, P.S. 6880
6-1-2023
Date:

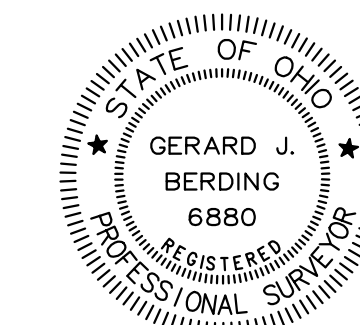

PID NO.
114603

R/W DESIGNER
TMS
R/W REVIEWER
GJB

CENTERLINE PLAT

WAR-TR55-2.11

3 / 17

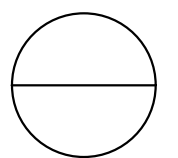

TOTAL NUMBER OF :
 4 OWNERSHIPS 0 TOTAL TAKES
 14 PARCELS 0 OWNERSHIPS W/ STRUCTURES INVOLVED

NET RESIDUE = RECORD AREA - TOTAL PRO - NET TAKE
 NET TAKE = GROSS TAKE - PRO IN TAKE

GRANTEE:
 ALL RIGHT OF WAY ACQUIRED IN THE NAME OF AND FOR
 THE BENEFIT OF DEERFIELD TOWNSHIP BOARD OF TRUSTEES,
 WARREN COUNTY, OHIO

ALL AREAS IN ACRES

PARCEL NO.	OWNER	SHEET NO.	OWNERS RECORD	AUDITOR'S PARCEL	RECORD AREA	TOTAL P.R.O.	GROSS TAKE	P.R.O. IN TAKE	NET TAKE	STRUC-TURE	NET RESIDUE		TYPE FUND	REMARKS	AS ACQUIRED	
											LEFT	RIGHT			BOOK	PAGE
1-SH	THE CITY OF MASON	4,6-11	O.R. 1474, PG. 331	16-27-355-023	1.5495	0.0000	0.3202	0.0000	0.3202	NO		1.2293	LOCAL	SEEDING/GRADING, REMOVE 1 TREE		
1-T							0.1674	0.0000	0.1674					SEEDING/GRADING, REMOVE 13 TREES		
1-SW1							0.0029	0.0000	0.0029							
1-SW2							0.0029	0.0000	0.0029							
1-SW3							0.0096	0.0000	0.0096							
2-SH	DEERFIELD TOWNSHIP TRUSTEES	4,10-13	O.R. 1321, PG. 941	16-27-355-026	9.6875	0.9734	0.0465	0.0000	0.0465			8.6676		SEEDING/GRADING		
2-T							0.0302	0.0000	0.0302					SEEDING/GRADING		
2-SW							0.0028	0.0000	0.0028							
3-SH	DEERFIELD TRAILS INC.	4,12-15	O.R. 4866, PG. 661	16-27-355-024	0.404	0.0258	0.1020	0.0000	0.1020			0.2762		SEEDING/GRADING		
3-T							0.0536	0.0000	0.0536					SEEDING/GRADING		
4-SH	THE PROCTER & GAMBLE COMPANY	4,14-17	O.R. 658, PG. 245	16-27-176-010	232.7195	0.1610	0.1030	0.0000	0.1030		231.8189	0.6366		SEEDING/GRADING		
4-T1							0.0269	0.0000	0.0269					SEEDING/GRADING		
4-T2							0.0175	0.0000	0.0175					SEEDING/GRADING		
4-SW							0.0125	0.0000	0.0125							
5	THE CINCINNATI GAS & ELECTRIC COMPANY	4,16,17	O.R. 763, PG. 22	16-27-355-021	4.6555	0.3627								NO TAKE		

FEDERAL PROJECT NO.
NON-FEDERAL
 PID NO. 114603
 STATE JOB NO.
 R/W DESIGNER TMS
 R/W REVIEWER GJB

SUMMARY OF ADDITIONAL
 RIGHT OF WAY

WAR - TR55 - 2.11

TYPES OF TITLE LEGEND:
 SH = STANDARD HIGHWAY EASEMENT
 T = TEMPORARY EASEMENT
 SW = SEWER EASEMENT

NOTE: ALL TEMPORARY PARCELS TO
 BE OF 12 MONTH DURATION.

NOTE: UNDER NO CIRCUMSTANCES ARE TEMPORARY
 EASEMENTS TO BE USED FOR STORAGE OF
 MATERIAL OR EQUIPMENT BY THE CONTRACTOR
 UNLESS NOTED OTHERWISE.

REV. BY	DATE	DESCRIPTION

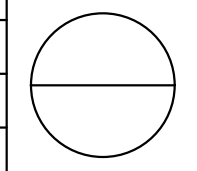

WAR-TR55-2.11

WARREN COUNTY
CITY OF MASON - DEERFIELD TOWNSHIP
SECTION 27, TOWN 4, RANGE 2
BETWEEN THE MIAMIS

CURVE	RADIUS	ARC LENGTH	DELTA ANGLE	CHORD BEARING	CHORD LENGTH
C2	862.00'	157.26'	10°27'11"	S 79°10'49" E	157.05'
C3	860.00'	156.90'	10°27'11"	N 79°10'48" W	156.68'
C4	43.33'	14.30'	18°54'12"	S 54°12'54" W	14.23'
C5	35.00'	40.45'	66°12'53"	N 62°29'09" E	38.23'
C6	35.00'	11.53'	18°52'05"	N 19°56'40" E	11.47'

LINE	BEARING	DISTANCE
L1	N 84°24'24" W	35.30'
L2	S 84°24'24" E	15.00'
L3	N 84°24'24" W	32.00'
L4	S 53°45'19" W	23.99'

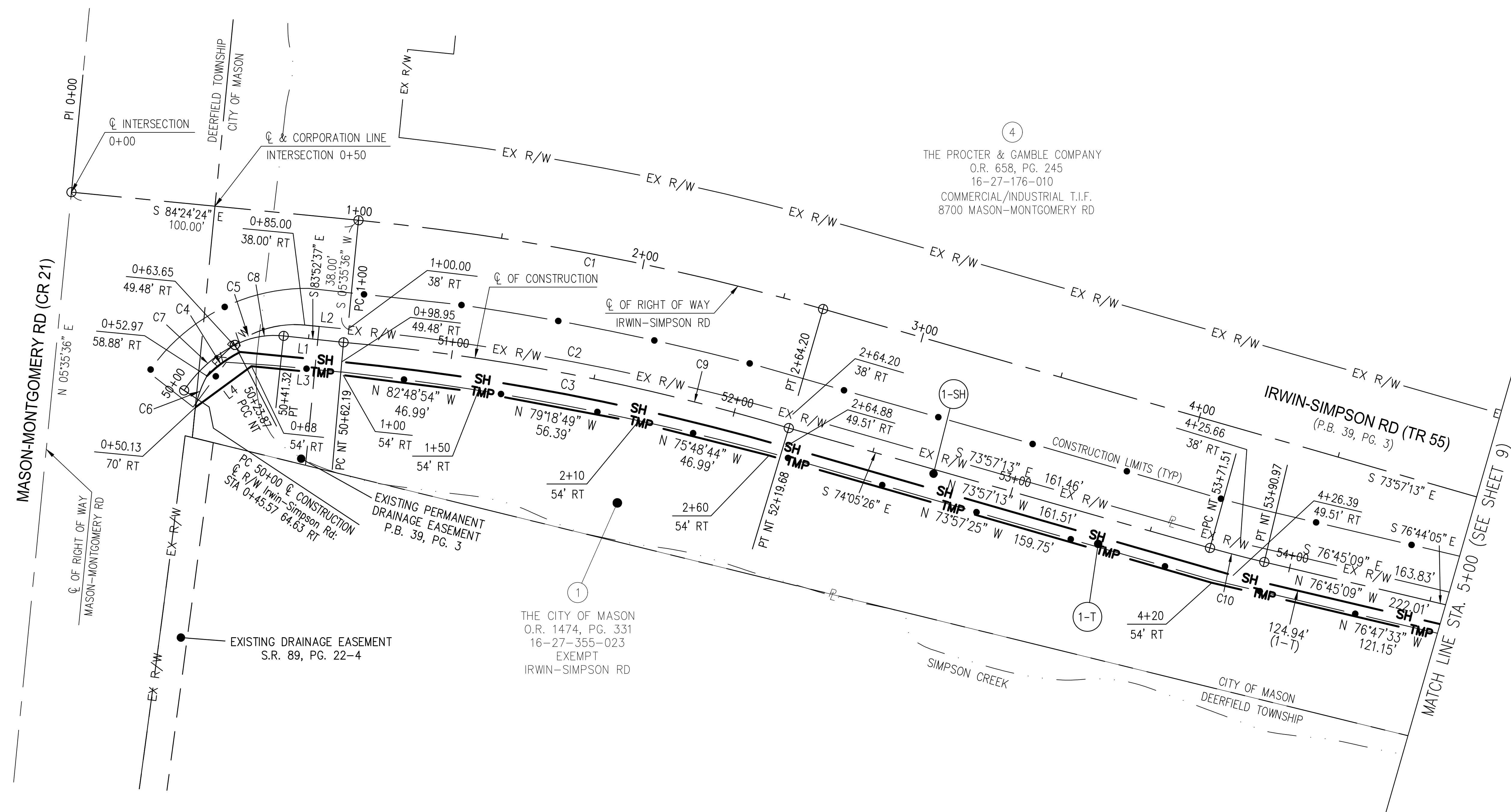
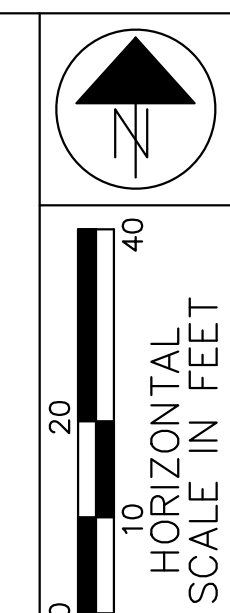

④
THE PROCTER & GAMBLE COMPANY
O.R. 658, PG. 245
16-27-176-010
COMMERCIAL/INDUSTRIAL T.I.F.
8700 MASON-MONTGOMERY RD

①
THE CITY OF MASON
O.R. 1474, PG. 331
16-27-355-023
EXEMPT
IRWIN-SIMPSON RD

<p>C1 $\text{C} \text{ R/W}$ PI STA 1+82.33 $\Delta = 10^{\circ}27'11''$ (RT) DC = 06'21'58" R = 900.00' T = 82.33' L = 164.20' E = 3.76' CH = 163.97' CH BRG = S 79°10'49" E</p>	<p>C7 $\text{C} \text{ CONSTRUCTION}$ PI STA 50+12.20 $\Delta = 29^{\circ}16'50''$ (RT) DC = 122'38'31" R = 46.72' T = 12.20' L = 23.87' E = 1.57' CH = 23.62' CH BRG = N 48°10'23" E</p>	<p>C8 $\text{C} \text{ CONSTRUCTION}$ PI STA 50+32.85 $\Delta = 33^{\circ}18'32''$ (RT) DC = 190'59'09" R = 30.00' T = 8.97' L = 17.44' E = 1.31' CH = 17.20' CH BRG = N 79°28'07" E</p>	<p>C9 $\text{C} \text{ CONSTRUCTION}$ PI STA 51+41.21 $\Delta = 11^{\circ}43'03''$ (RT) DC = 7'26'24" R = 770.09' T = 79.02' L = 157.49' E = 4.04' CH = 157.22' CH BRG = S 79°06'16" E</p>	<p>C10 $\text{C} \text{ CONSTRUCTION}$ PI STA 53+81.24 $\Delta = 02^{\circ}09'27''$ (LT) DC = 11'04'56" R = 517.01' T = 9.74' L = 19.47' E = 0.09' CH = 19.47' CH BRG = S 75°32'33" E</p>
---	---	--	--	---

REV. BY	DATE	DESCRIPTION

PID NO.
114603

R/W DESIGNER
TMS
R/W REVIEWER
GJB

RIGHT OF WAY BOUNDARY SHEET
STA 0+00 - STA 5+00

WAR-TR55-2.11

7/17

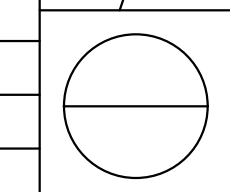

WAR-TR55-2.11

WARREN COUNTY
CITY OF MASON - DEEFIELD TOWNSHIP
SECTION 27, TOWN 4, RANGE 2
BETWEEN THE MIAMIS

CURVE	RADIUS	ARC LENGTH	DELTA ANGLE	CHORD BEARING	CHORD LENGTH
C2	1030.00'	491.18'	27°19'23"	S 87°36'54" E	486.54'
C3	1038.67'	495.32'	27°19'23"	N 87°36'54" W	490.64'
C4	1038.67'	153.98'	08°29'38"	S 78°12'02" E	153.84'
C5	1038.67'	312.41'	17°13'59"	N 88°21'55" E	311.23'
C6	1038.67'	10.34'	00°34'14"	S 82°43'58" E	10.34'

LINE	BEARING	DISTANCE
L1	S 11°14'23" E	15.04'
L2	N 78°45'37" E	10.00'
L3	N 11°14'23" W	10.49'
L4	S 07°32'22" E	14.13'
L5	N 82°27'38" E	10.00'
L6	N 07°32'22" W	11.49'
L7	S 40°15'40" W	13.22'
L8	S 81°10'10" W	10.97'
L9	N 38°40'27" W	20.30'
L10	N 80°54'05" W	35.46'
L11	N 77°00'23" W	75.11'
L12	S 52°54'59" W	10.00'
L13	S 79°28'53" W	11.18'
L14	N 40°15'49" W	21.63'
L15	N 76°47'33" W	121.15'
L16	S 76°45'09" E	10.99'

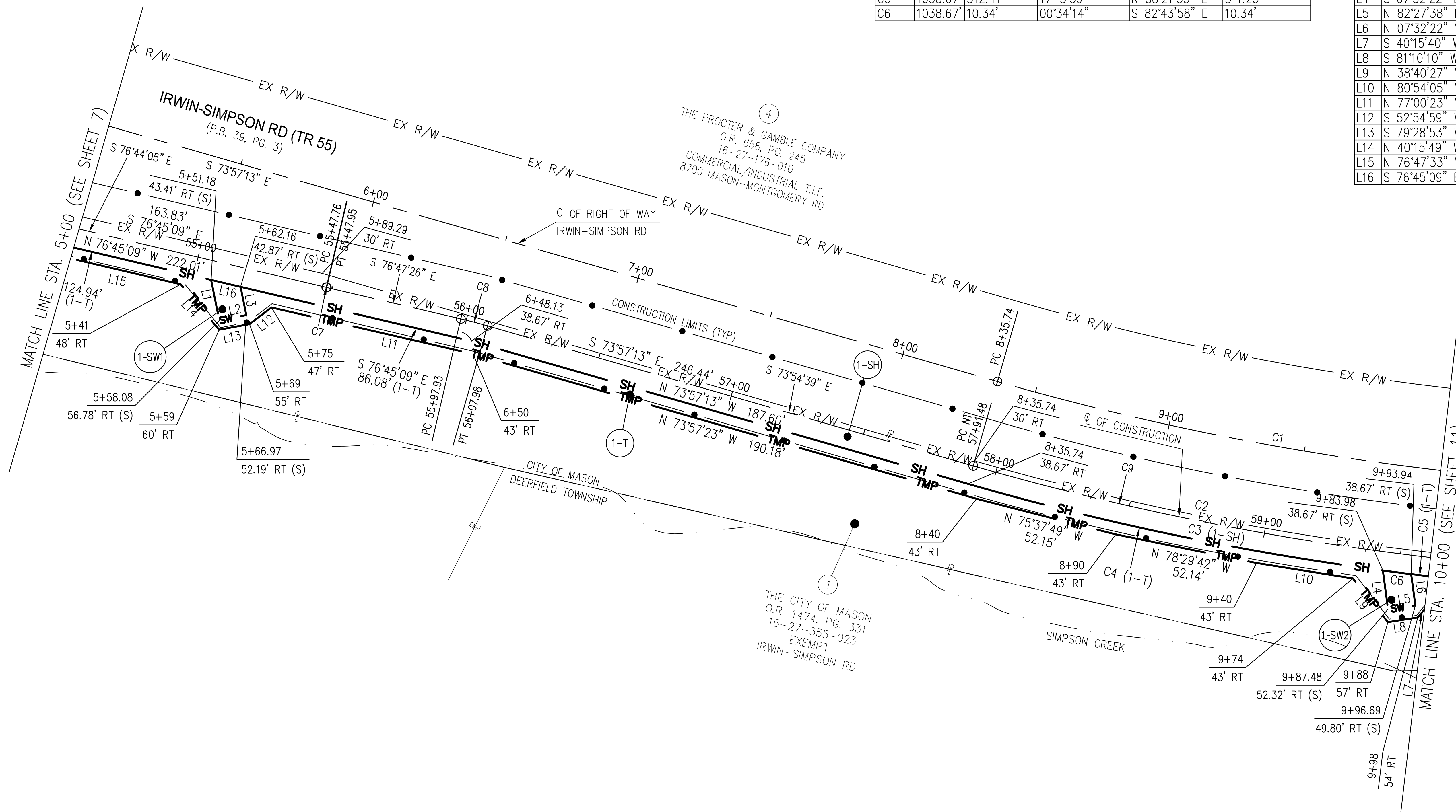
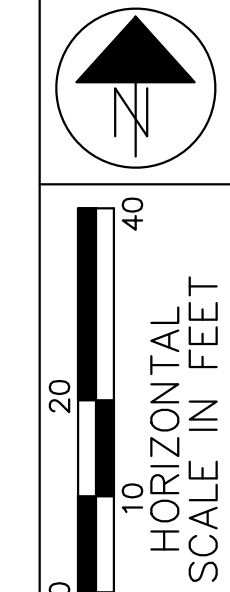

<p>C1 ϕ R/W PI STA 10+78.80 $\Delta = 27^\circ 19' 23''$ (LT) DC = 05°43'46" R = 1000.00' T = 243.06' L = 476.88' E = 29.12' CH = 472.37' CH BRG = S 87°36'55" E</p>	<p>C7 ϕ CONSTRUCTION PI STA 55+47.85 $\Delta = 00^\circ 03' 21''$ (LT) DC = 28°38'53" R = 200.00' T = 0.10' L = 0.20' E = 0.00' CH = 0.20' CH BRG = S 76°45'46" E</p>	<p>C8 ϕ CONSTRUCTION PI STA 56+02.95 $\Delta = 02^\circ 52' 47''$ (RT) DC = 28°38'52" R = 200.00' T = 5.03' L = 10.05' E = 0.06' CH = 10.05' CH BRG = S 75°21'03" E</p>	<p>C9 ϕ CONSTRUCTION PI STA 60+42.29 $\Delta = 27^\circ 19' 08''$ (LT) DC = 05°33'06" R = 1032.03' T = 250.81' L = 492.08' E = 30.04' CH = 487.43' CH BRG = S 87°37'17" E</p>
---	--	--	--

REV. BY	DATE	DESCRIPTION

PID NO. 114603

R/W DESIGNER TMS
R/W REVIEWER GJB

RIGHT OF WAY BOUNDARY SHEET
STA 5+00 - STA 10+00

WAR-TR55-2.11

WAR-TR55-2.11

WARREN COUNTY
CITY OF MASON - DEEFIELD TOWNSHIP
SECTION 27, TOWN 4, RANGE 2
BETWEEN THE MIAMIS

C1 ϕ R/W
PI STA 19+27.94
 $\Delta = 11^{\circ}08'31''$ (RT)
DC = $06^{\circ}21'58''$
R = 900.00'
T = 87.79'
L = 175.02'
E = 4.27'
CH = 174.74'
CH BRG = N $84^{\circ}17'39''$ E

C4 ϕ CONSTRUCTION
PI STA 68+95.76
 $\Delta = 11^{\circ}06'14''$ (RT)
DC = $06^{\circ}34'37''$
R = 871.16'
T = 84.68'
L = 168.83'
E = 4.11'
CH = 168.57'
CH BRG = N $84^{\circ}18'41''$ E

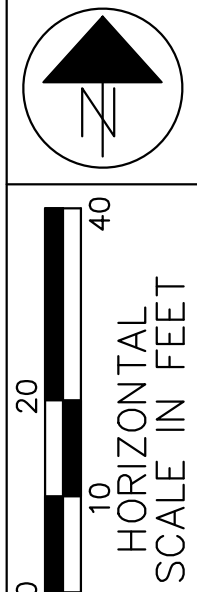

PID NO. 114603
R/W DESIGNER TMS
R/W REVIEWER GJB

RIGHT OF WAY TOPO SHEET
STA 15+00 - STA 20+00

WAR-TR55-2.11

12/17

REV. BY	DATE	DESCRIPTION

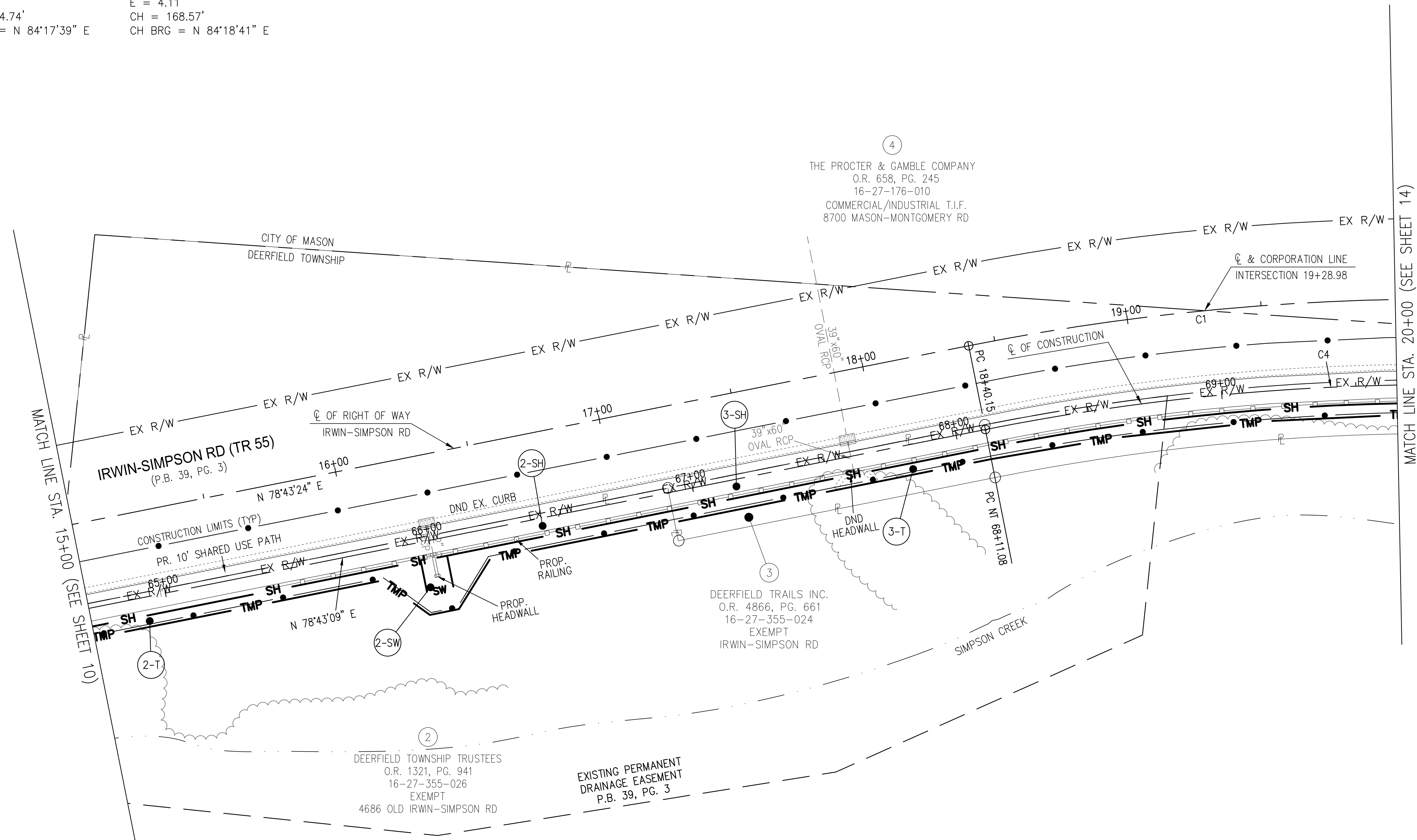

MATCH LINE STA. 15+00 (SEE SHEET 10)

MATCH LINE STA. 20+00 (SEE SHEET 14)

WAR-TR55-2.11

WARREN COUNTY
CITY OF MASON - DEEFIELD TOWNSHIP
SECTION 27, TOWN 4, RANGE 2
BETWEEN THE MIAMIS

C1 ϕ R/W	C4 ϕ CONSTRUCTION
PI STA 19+27.94	PI STA 68+95.76
$\Delta = 11^{\circ}08'31"$ (RT)	$\Delta = 11^{\circ}06'14"$ (RT)
DC = $06^{\circ}21'58"$	DC = $06^{\circ}34'37"$
R = 900.00'	R = 871.16'
T = 87.79'	T = 84.68'
L = 175.02'	L = 168.83'
E = 4.27'	E = 4.11'
CH = 174.74'	CH = 168.57'
CH BRG = N $84^{\circ}17'39"$ E	CH BRG = N $84^{\circ}18'41"$ E

LINE	BEARING	DISTANCE
L1	S $11^{\circ}16'36"$ E	8.67'
L2	S $11^{\circ}16'36"$ E	4.33'
L3	S $31^{\circ}52'33"$ W	21.93'
L4	S $78^{\circ}43'24"$ W	11.00'
L5	N $54^{\circ}25'45"$ W	21.93'
L6	S $11^{\circ}21'00"$ E	12.10'
L7	N $78^{\circ}39'00"$ E	10.00'
L8	N $11^{\circ}21'00"$ W	12.08'
L9	N $78^{\circ}43'24"$ E	10.00'

CURVE	RADIUS	ARC LENGTH	DELTA ANGLE	CHORD BEARING	CHORD LENGTH
C2	861.33'	167.50'	$11^{\circ}08'31"$	S $84^{\circ}17'39"$ W	167.23'
C3	870.00'	169.18'	$11^{\circ}08'31"$	N $84^{\circ}17'39"$ E	168.92'

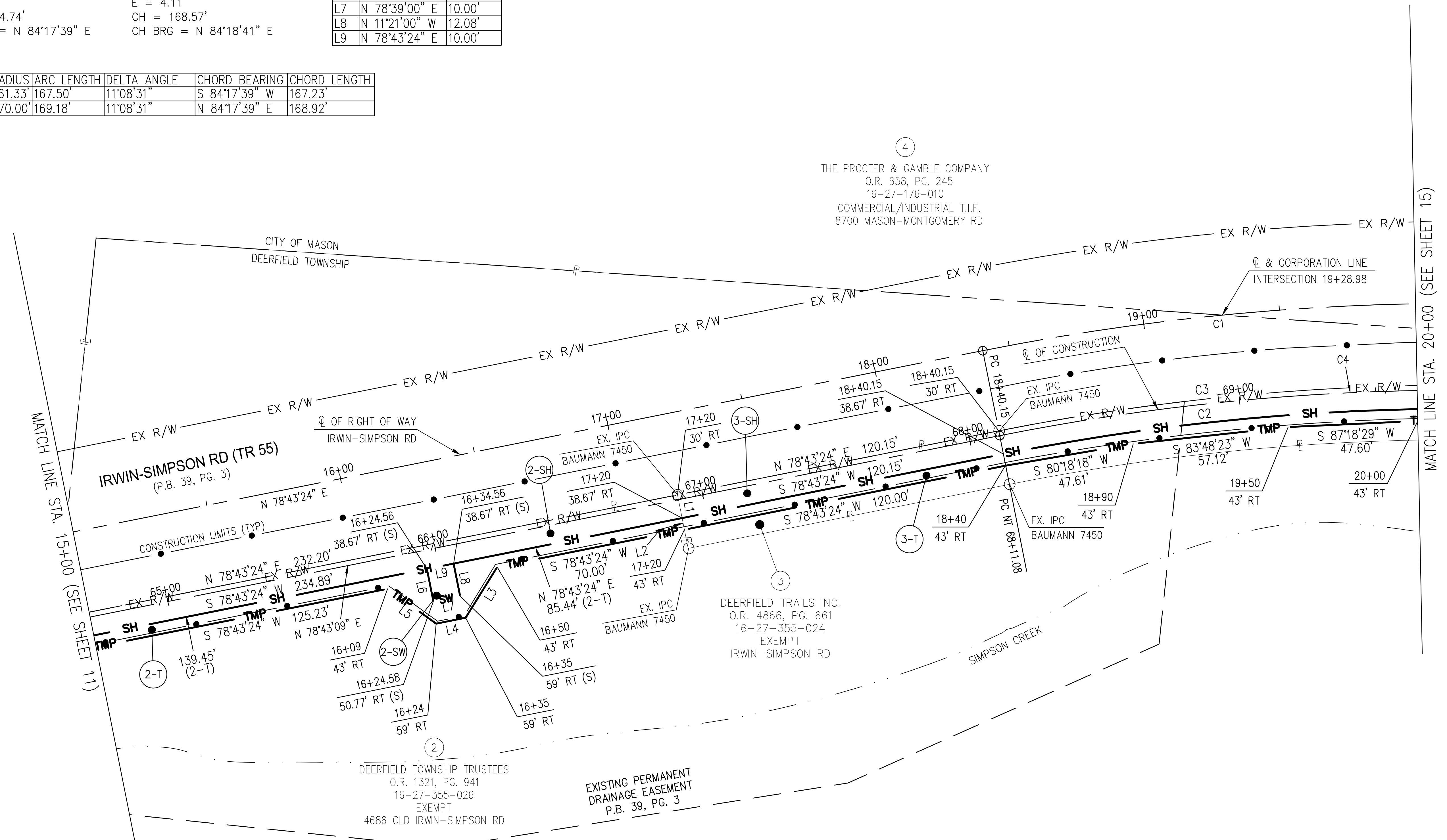

THE PROCTER & GAMBLE COMPANY
O.R. 658, PG. 245
16-27-176-010
COMMERCIAL/INDUSTRIAL T.I.F.
8700 MASON-MONTGOMERY RD

DEERFIELD TRAILS INC.
O.R. 4866, PG. 661
16-27-355-024
EXEMPT
IRWIN-SIMPSON RD

DEERFIELD TOWNSHIP TRUSTEES
O.R. 1321, PG. 941
16-27-355-026
EXEMPT
4686 OLD IRWIN-SIMPSON RD

EXISTING PERMANENT
DRAINAGE EASEMENT
P.B. 39, PG. 3

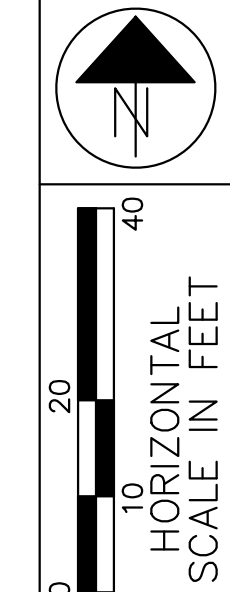

PID NO.
114603

R/W DESIGNER
TMS

R/W REVIEWER
GJB

RIGHT OF WAY BOUNDARY SHEET
STA 15+00 - STA 20+00

WAR-TR55-2.11

REV. BY	DATE	DESCRIPTION

A TIE 2-SH, 2-T & 2-SW:
 R=930.00' A=441.35' D=27°11'26"
 CH=S 76°16'12" W L=437.22'
 FROM STA 25+42.28, 30' RT

WAR-TR55-2.11

WARREN COUNTY
 CITY OF MASON - DEEFIELD TOWNSHIP
 SECTION 27, TOWN 4, RANGE 2
 BETWEEN THE MIAMIS

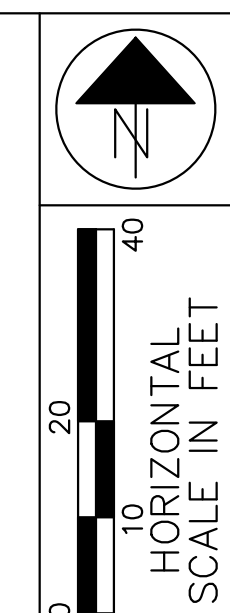

PID NO. 114603
 R/W DESIGNER TMS
 R/W REVIEWER GJB

RIGHT OF WAY BOUNDARY SHEET
 STA 20+00 - STA 25+00

WAR-TR55-2.11

15/17

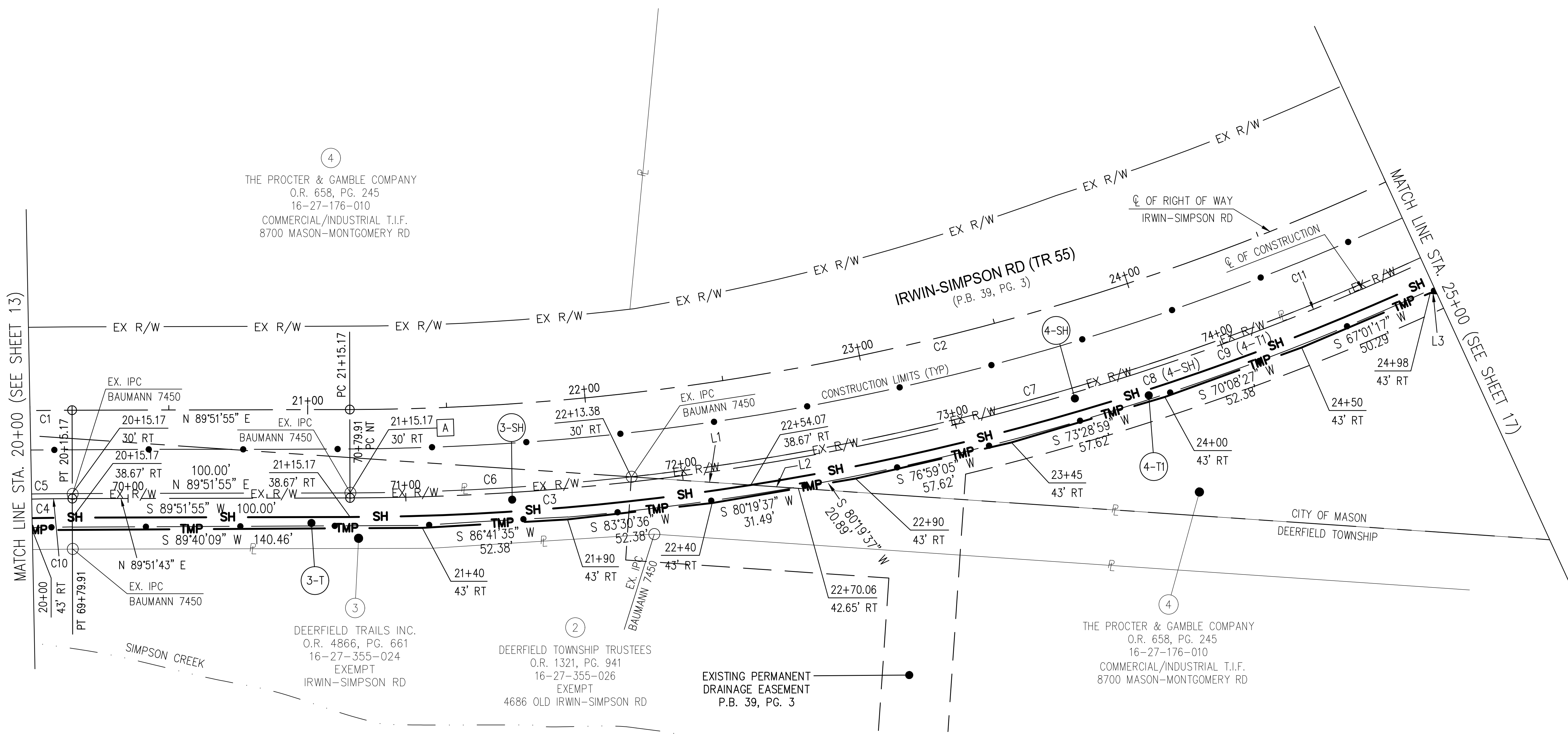
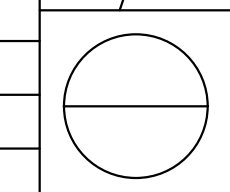

Curve	Radius	Arc Length	Delta Angle	Chord Bearing	Chord Length
C3	938.67'	144.87'	08°50'34"	S 85°26'38" W	144.73'
C4	861.33'	167.50'	11°08'31"	S 84°17'39" W	167.23'
C5	870.00'	169.18'	11°08'31"	N 84°17'39" E	168.92'
C6	930.00'	101.49'	06°15'09"	N 86°44'21" E	101.44'
C7	930.00'	339.86'	20°56'17"	N 73°08'38" E	337.97'
C8	938.67'	300.59'	18°20'52"	S 71°50'55" W	299.31'
C9	938.67'	262.82'	16°02'33"	N 73°00'05" E	261.96'

Line	Bearing	Distance
L1	S 86°05'06" E	43.12'
L2	S 86°05'06" E	17.18'
L3	N 86°04'28" W	38.49'

REV. BY	DATE	DESCRIPTION

WAR-TR55-2.11

WARREN COUNTY
CITY OF MASON - DEEFIELD TOWNSHIP
SECTION 27, TOWN 4, RANGE 2
BETWEEN THE MIAMIS

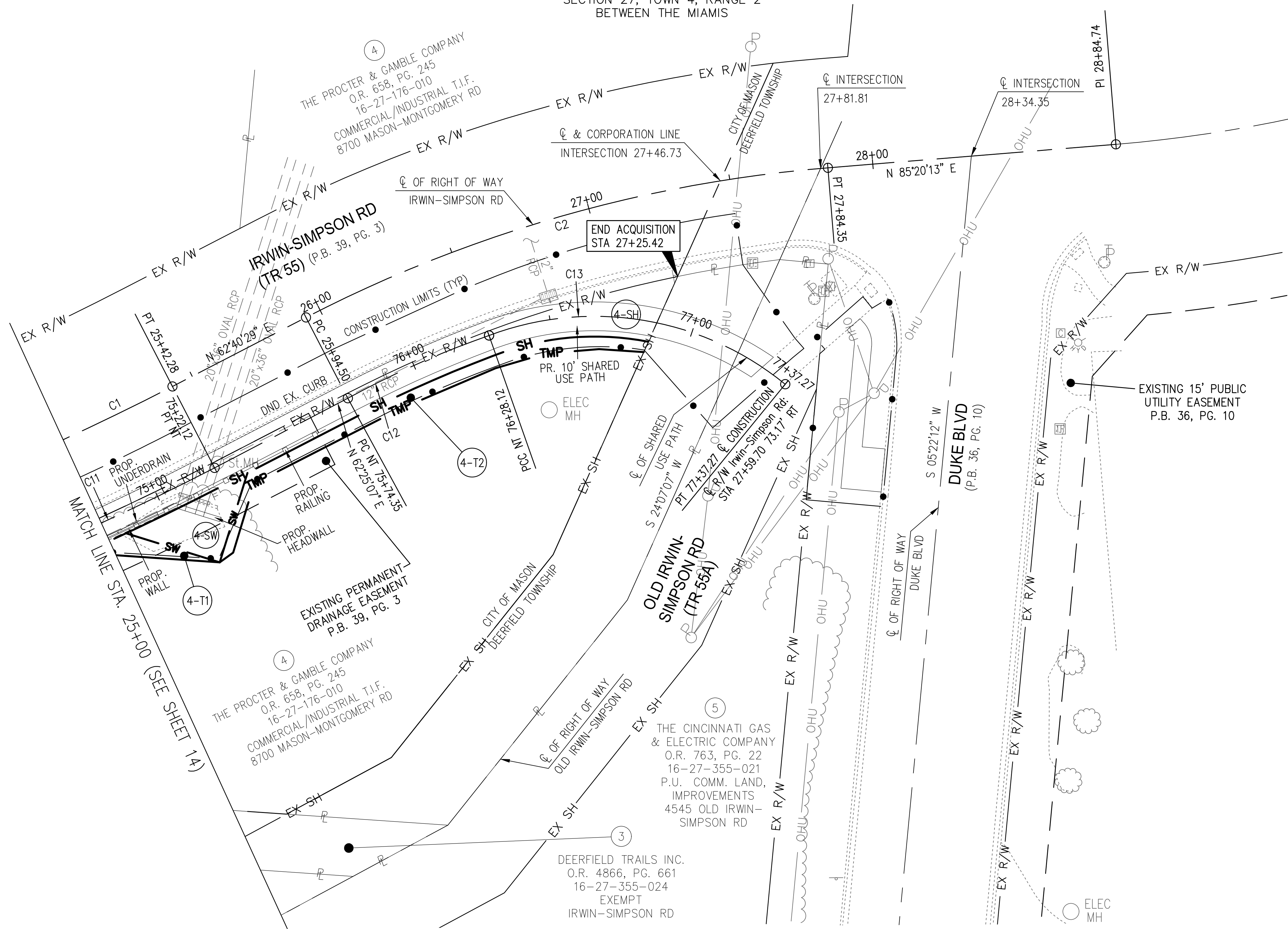

C1 ϕ R/W
PI STA 23+32.83
 $\Delta = 27^{\circ}11'26''$ (LT)
DC = 06'21'58"
R = 900.00'
T = 217.65'
L = 427.11'
E = 25.94'
CH = 423.11'
CH BRG = N 76'16'12" E

C2 ϕ R/W
PI STA 23+90.68
 $\Delta = 22^{\circ}39'44''$ (RT)
DC = 11'56'12"
R = 480.00'
T = 96.18'
L = 189.85'
E = 9.54'
CH = 188.62'
CH BRG = N 74'00'21" E

C11 ϕ CONSTRUCTION
PI STA 73+05.26
 $\Delta = 27^{\circ}10'33''$ (LT)
DC = 06'08'44"
R = 932.33'
T = 225.35'
L = 442.21'
E = 26.85'
CH = 438.08'
CH BRG = N 76'16'20" E

C12 ϕ CONSTRUCTION
PI STA 76+01.29
 $\Delta = 09^{\circ}10'27''$ (RT)
DC = 17'03'45"
R = 335.80'
T = 26.94'
L = 53.77'
E = 1.08'
CH = 53.71'
CH BRG = N 66'02'00" E

C13 ϕ CONSTRUCTION
PI STA 76+88.24
 $\Delta = 59^{\circ}43'55''$ (RT)
DC = 54'43'23"
R = 104.70'
T = 60.12'
L = 109.15'
E = 16.03'
CH = 104.28'
CH BRG = S 80'39'16" E

REV. BY	DATE	DESCRIPTION

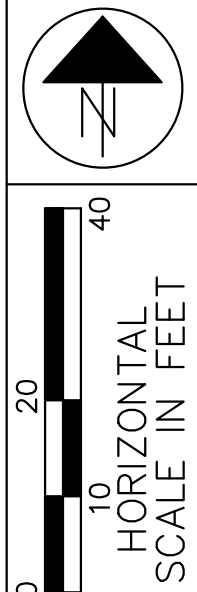

PID NO. 114603
R/W DESIGNER TMS
R/W REVIEWER GJB

RIGHT OF WAY TOPO SHEET
STA 25+00 - STA 28+84.74

WAR-TR55-2.11

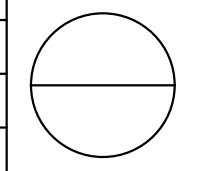

**WARREN COUNTY
TRANSPORTATION IMPROVEMENT
DISTRICT**

BID PACKAGE

WAR-TR55-2.11

PROJECT NO. 2023-05

DBE = 8%

**Deerfield Township
WARREN COUNTY, OHIO**

TABLE OF CONTENTS

WAR-TR55-2.11

PROJECT NO. 2023-05

SECTION I. Notice to Contractors	1 Page
SECTION II. <i>General Instructions to Bidders</i>	4 Pages
SECTION III. <i>General Provisions</i>	18 Pages
SECTION IV. Federal and State Requirements	37 Pages
SECTION V. <i>Bid Proposal and Bid Guaranty</i>	5 Pages
SECTION VI. <i>Affidavits</i>	2 Pages
SECTION VII. <i>Prevailing Wage Rates</i>	39 Pages
SECTION VIII. <i>Sample Contract and Change Order Form</i>	2 Pages
SECTION IX. <i>Utility Notes</i>	1 Pages
TOTAL	109 Pages

SECTION I

Notice to Contractors

LEGAL NOTICE TO CONTRACTORS

The Warren County Transportation Improvement District (WCTID), in cooperation and coordination with the Warren County Engineer's Office, will be accepting sealed bids for the furnishing of all labor, equipment, and materials needed to construct ODOT PID **114603 : WAR-TR55-2.11** (aka Irwin-Simpson Road Shared Use Path) in accordance with the applicable Ohio Department of Transportation Construction and Material Specifications (effective January 1, 2023 and its revisions and supplements), Standard Construction Drawings, Standard Bridge Drawings, Ohio Manual of Uniform Traffic Control, The State of Ohio Department of Transportation Bridge Design Manual, and other applicable standards in force on the date of letting and in accordance with the Project Specifications and Construction Plans on file in the office of the Warren County Engineer.

This project is Construct shared use trail along Irwin Simpson from Mason Montgomery Road to the existing trail just west of Duke Boulevard in Deerfield Township, Warren County, Ohio. The Engineer's estimate for this project is Eight Hundred and Fifty Thousand Dollars and no cents (\$850,000.00).

All bids must be submitted in conformance with the requirements of the Project Specifications and in a sealed envelope marked: ODOT PID **114603: WAR-TR55-2.11**, and received in the office of the Warren County Engineer, 210 W Main Street, Lebanon, Ohio 45036, no later than 11:00 a.m. Local Time on Thursday, December 14, 2023, and then at said time bids will be opened and read aloud.

Bid documents and specifications are available after November 13, 2023, on the Warren County website at <http://www.co.warren.oh.us/commissioners/Bids/Default.aspx>. Questions regarding the technical specifications should be directed to Dan Corey, P.E., Warren County Engineer's Office at 513-431-1229 or Dan.Corey@co.warren.oh.us. **Each contractor shall be ODOT prequalified.**

This notice is posted on the Warren County website at: <https://www.co.warren.oh.us/Commissioners/Bids/Default.aspx>. Contact the Warren County Commissioner's Office at (513) 695-1250 should you need assistance in accessing the bidding information on the County's website. **All contract addenda will be posted to the website prior to the bid opening. Bidders should check the website regularly to stay updated on any changes to the project.**

Please be aware that if you are downloading this document to bid this project, and in order to stay updated on any change, please email Krystal Powell in the Commissioners' Office at krystal.powell@co.warren.oh.us with your contact information.

Bidders must comply with the Davis Bacon prevailing wage rates, herein this Bid Package. Bidders must be ODOT Prequalified for the applicable work types at the time of bidding, award, and throughout the life of the construction contract.

WCTID reserves the right to waive any informalities, reject any or all bids and to hold such bids for a period of sixty (60) days before taking any action thereon, and to award a contract to the best, most responsive and responsible Bidder.

WARREN COUNTY TRANSPORTATION IMPROVEMENT DISTRICT
WARREN COUNTY, OHIO

SECTION II

General Instructions to Bidders

GENERAL INSTRUCTIONS TO BIDDERS FOR PUBLIC IMPROVEMENTS

Irwin-Simpson Shared Use Path, Deerfield Township, Warren County

PROJECT NO. 2023-05

SECTION II 100 ITEM BID (DESCRIPTION OF WORK)

- II 100.1** Work under consideration for bidding purposes shall be that Work as shown on the Project Plans and Specifications to provide all the labor and materials necessary to construct PROJECT NO 2023-05: **WAR-TR55-2.11**, located in Deerfield Township, in Warren County, Ohio, in accordance with the Project Specifications and Construction Plans (the "Specifications") on file in the office of the Warren County Engineer. This project is located on Irwin-Simpson in Deerfield Township, Warren County, OH.
- II 100.2** All bids submitted for consideration by the WCTID must comply with these instructions in order to be considered. These instructions set forth minimum requirements as the terms and conditions of the purchase. Therefore, if any time frames, bid bond or other surety requirements set forth herein are in conflict with stated requirements in the Specifications, the specification requirements shall prevail.
- II 100.3** It is intended that the Specifications governing this project (and any bidding requirements and conditions) and any ODOT specifications or references to the Ohio Revised Code as set forth herein, and any attachments(s) or documents incorporated by reference herein, be construed harmoniously wherever possible in order to carry out the full intent and purposes of the WCTID with respect to this project. But if there is a conflict or inconsistency between any provisions(s) of the ODOT specifications or references to the Ohio Revised Code and those contained herein, the provisions(s) granting rights, remedies, discretion and/or latitude to the WCTID, or imposing the greater duty, standard, responsibility and/or obligation on the successful Bidder (hereinafter referred to as the "Contractor"), shall govern.

SECTION II 200 THE WCTID

- II 200.1** The WCTID is the Warren County Transportation Improvement District, 210 West Main Street, Lebanon, OH 45036, and is referred to throughout the Contract Documents as if singular in number.
- II 200.2** The WCTID is exempt from State sales tax. Contractors shall provide Exemption Certificate to the WCTID for signature as required. Each Contractor and subcontractor must procure Vendor's License as required by law. Warren County is exempt from payment of Federal Excise Tax, Transportation Tax and Ohio State Tax. Prices shall not include these taxes.

SECTION II 300 ENGINEER

- II 300.1** The term "Engineer" shall be taken to mean the Warren County Engineer.
- II 300.2** The term SHA (State Highway Agency) referred to in Section IV, Federal and State Requirements shall be taken to mean the WCTID.

SECTION II 400 SUBMISSION OF BID PROPOSALS

- II 400.1** Bids shall be submitted in a sealed envelope marked accordingly with item(s) bid on and name of Bidder, and delivered in compliance with the Legal Notice. Any improperly marked bid will not be considered.
- II 400.2** Bidders must be on The Ohio Department of Transportation's Prequalified Contractors List. In addition, Bidders must be prequalified for the necessary Work types to complete the project.

II 400.3 All bids must comply with the specifications attached hereto. Alternative bids may be considered only if clearly marked as such with an explanation as to how the item is sufficient to meet required needs. In the absence of such marking and explanation the bid may be rejected or, in WCTID's sole discretion, if the bid is accepted Bidder agrees that the bid shall be deemed modified to be fully compliant with the applicable specifications as if there was no deviation.

II 400.4 Each person bidding for a contract for the construction, demolition, alteration, repair, or reconstruction of any public improvement is required to file with its bid a bid guaranty in the form of either (1) a bond for the full amount of the bid or (2) a certified check, cashier's check or irrevocable letter of credit pursuant to Chapter 1305 of the Ohio Revised Code in an amount equal to ten (10) percent of the bid pursuant to Section 153.54 of the Ohio Revised Code. The successful Bidder at the time he/she enters into the contract shall be required to file a performance bond in the full amount of the contract pursuant to Section 153.54(c) of the Ohio Revised Code. In lieu of a Performance Bond, Bidder may submit a Combined Bid Guaranty and Contract Bond in conformance with Ohio Revised Code Section 153.571 with the proposal. Each bond must be accompanied by an effectively dated Power of Attorney which authorizes the agent to sign on behalf of the surety.

Attention Bidders: Letters of credit and bid bonds must be filed with original signatures. Facsimile and electronic copies of the letter of credit, bid bond and Power of Attorney of the Surety will be deemed non-responsive.

II 400.5 All Bidders are required to submit the following affidavits with their bid proposal and the successful Bidder will be required to enter into a written contract with the WCTID (the "Contract") within ten (10) days of the notification of the award thereof:

(A) Non-Collusion Affidavit

(B) Affidavit Affirming Compliance with 9.24 and 5719.042 ORC

These affidavits and specifications heretofore referenced shall be incorporated into and become part of the contract document. Failure to include the two (2) above-referenced affidavits will disqualify the bid submitted for consideration. Should a bid be awarded, and the WCTID later determine that the affidavit was incorrect or falsified, the Contract shall be immediately canceled and the Bidder subject to the penalties and damages, both civil and criminal, as provided by law and this Contract.

II 400.6 The WCTID reserves the right to waive any informalities, to reject any or all bids, to accept any bid which may be deemed to be for the best interest of the WCTID and to hold such bids for a period of sixty (60) days before taking any action.

II 400.7 The Proposal forms furnished with these documents shall be completed in full; in writing in ink (or typewritten) and signed in ink. Affix the corporation seal on the proposal forms.

II 400.8 Proposals are due at the place, date, and time indicated in the Legal Notice and will be opened publicly and read aloud.

II 400.9 All prices, quantities, etc. as bid must be firm for a period of sixty (60) days from the date of the bid opening.

II 400.10 Contractor hereby agrees to defend, indemnify, and hold the WCTID, Warren County, and the Engineer, and their respective officers, trustees, commissioners, employees, members, agents, and volunteers harmless from any claims, demands or losses of any type or nature to any person, Bidder or corporation arising in any manner from the Contractor's performance or failure to perform the Work required under this Contract and shall pay any liabilities, judgments (including reasonable attorney's fees and litigation expenses) or losses.

II 400.11 All materials and exhibits submitted in the bid response shall become the property of WCTID and will not be returned to the Bidder. All bids received constitute public information as a matter of statutory law and will be made available for public inspection and copying upon request by members

of the public pursuant to the requirements of Section 149.43 of the Ohio Revised Code. Any portion of the bid that the Bidder requires to be treated as confidential in nature must be marked to that effect and provided that the information falls within an appropriate exemption enumerated under Section 149.43 of the Ohio Revised Code, that portion will not be considered public record. A blanket indication of confidentiality or privilege will not be accepted and unless specific materials that fall within the appropriate statutory exemption are identified, the entire bid response will be treated as a public record.

SECTION II 500 GENERAL BID SPECIFICATIONS

- II 500.1** Unless otherwise specified, all material shall be new and of the best grade in its particular line and all articles shall be complete and in first class condition. All Work shall be done in the best and most skilled manner, exactly as specified or detailed, and shall be subject to the approval of the Engineer and/or the WCTID. When required in the specifications, Bidders shall make available for inspection a sample or similar model of the bid item prior to the award of the bid.
- II 500.2** Reference to a particular trade name, manufacturer's catalog or model number for descriptive purposes is intended to guide the Bidder in interpreting the requirements of the Engineer and/or the WCTID and should not be construed as excluding proposals on other types of materials, equipment and supplies. However, the Bidder, if awarded the Contract, will be required to furnish the particular item referred to in the specifications or description unless a departure or substitution is clearly noted and described in the bid proposal and is accepted by the WCTID.
- II 500.3** Every effort shall be made by the Bidder awarded the Contract to deliver items by or before the time designated in the Contract. Any delinquency in such delivery without satisfactory written explanation directed to the WCTID may result in cancellation of the Contract and substitution of other goods. The defaulting Bidder shall be liable for any such default, or damages, costs, or expenses arising therefrom.
- II 500.4** In case of default by the Bidder or Contractor, WCTID may procure the articles or service from other sources without further advertising and shall hold the Bidder or Contractor responsible for any excess costs occasioned thereby, including any reasonable expenses incurred in procuring the articles or services.

SECTION II 600 INTERPRETATION OF DOCUMENTS

- II 600.1** If the Bidder is in doubt as to true meaning of any part of Drawings, Specifications, or other Contract Documents, submit a written request for an interpretation therefor to the Engineer and the WCTID. The Bidder making a request will be responsible for its prompt delivery. Any interpretation of the Contract Documents will be made by written notice or Addendum duly issued to each prospective Bidder.
- II 600.2** Addenda may be issued not later than 3 working days preceding bid due date. Questions requiring interpretation within 3 working days of bid due date will be recorded and answered during the bid negotiations preceding the signing of the contract or may result in an extension of the bid due date at the sole discretion of the WCTID.

SECTION II 700 EXAMINATION OF PLANS, SPECIFICATIONS, AND SITE OF WORK

- II 700.1** The Bidder is expected to examine carefully the site of the proposed Work, the proposal, plans specifications, contract forms, general conditions, and addenda, before submitting a proposal. The submission of a bid shall be considered evidence that the Bidder has made such examination and is satisfied as to the conditions to be encountered in performing the Work and as to the requirements of the plans, specifications, special provisions, general conditions, addenda and Contract.
- II 700.2** Subject to public safety and convenience, prospective Bidders will be permitted to explore the site of the Work by boring or test pits, permits for which will be issued by the Owner. Explorations shall be at the sole risk and expense to the Bidder and under conditions of maintaining and restoring safety.

II 700.3 The WCTID and the Engineer does not make any representation of soil or foundation conditions or materials, nor does it represent that drawing may not be modified to meet changes in soil conditions encountered as the Work progresses. The Contractor must inspect the site of the proposed Work and must assume all risk as to the nature and behavior of the material which may be encountered in excavation, whether apparent on the surface or disclosed only in the course of the Work. Any geotechnical subsurface investigation or soil boring logs that may be provided by the WCTID are provided for general information only to Contractors for this project and do not change the obligations or responsibilities set forth herein. It is the sole responsibility of the Contractor to take any and all measures it feels necessary to determine the subsurface conditions prior to bidding and the nature and extent of the subsurface conditions (including variations, if any, between borings and observation locations) may not be evident until construction. In order to induce the WCTID to enter into a Contract for the work, Contractor represents that it understands its obligations hereunder and that: (a) during construction, it will be required to provide all labor, equipment, materials, and other measures to construct the improvements regardless of the subsurface conditions encountered; (b) No claims for additional costs will be considered for material, labor, equipment, or subcontractors/subconsultants to address subsurface conditions encountered during construction; and (c) costs for all related activities shall be incidental to the Project.

SECTION II 800 AWARD OF CONTRACT

II 800.1 The selection of the Bidder is at the sole discretion of the WCTID. **PROJECT NO 2023-05, WAR-TR55-2.11**, will be awarded as soon as practicable, after opening of bids.

II 800.2 In determining the Bidder, the WCTID will consider, but not be limited to, the following criteria in addition to the Bid Amount:

- A. Bidder involved maintains permanent place of business.
- B. Bidder has adequate equipment and facilities to perform the Work properly and expeditiously.
- C. Bidder has suitable financial status to meet obligations incident to the Work.
- D. Bidder has appropriate technical experience.
- E. Bidder can complete the Work in timely and expeditious manner.

II 800.3 When analyzing the bids submitted, superior design, technology, workmanship, materials, size of component parts, operating costs, warranty, service facility etc. will be considered in addition to the price of the bid. It is WCTID's intent to accept the bid for which a thorough analysis of the bids submitted, proves to be the most suitable for the intended use. WCTID will consider awarding the Contract to the lowest and best Bidder, but reserves the right to reject any or all bids.

II 800.4 The WCTID further reserves the right to conduct such investigations and meetings as it deems necessary after receipt of bids to assist in the evaluation of any bid and to establish the responsibility, qualifications and financial ability of the Bidders, proposed sub-contractors and other persons and organizations to do the Work in accordance with the Contract Documents to the WCTID's satisfaction within the prescribed time limits. In order to facilitate this investigation, the apparent lowest and best Bidder may be required to complete a Bidders Qualification Questionnaire.

SECTION III

General Provisions

GENERAL PROVISIONS

WARREN COUNTY, OHIO

WAR-TR55-2.11

PROJECT NO. 2023-05

The Specifications, General Instructions, General Provisions and Special Provisions contained herein are Contract Documents, together with, the State of Ohio, Department of Transportation, Construction and Material Specifications incorporated in the Contract and not specifically excluded, and are to be read in conjunction with said ODOT Specifications. It is intended that the Specifications, General Instructions, General Provisions and Special Provisions governing this project (and any bidding requirements and conditions) and any ODOT specifications or references to the Ohio Revised Code as set forth herein, and any attachments(s) or documents incorporated by reference herein, be construed harmoniously wherever possible in order to carry out the full intent and purposes of the WCTID with respect to this project. But if there is a conflict or inconsistency between any provisions(s) of the ODOT specifications or references to the Ohio Revised Code and those contained herein, the provisions(s) granting greater rights, remedies, discretion and/or latitude to the WCTID, or imposing the greater duty, standard, responsibility and/or obligation on the Contractor shall govern.

SECTION III 100 DEFINITIONS

III 100.1 WCTID - Whenever the word "WCTID" is used, it shall be held to mean the Warren County Transportation Improvement District, Warren County, Ohio. The word "WCTID" shall also be substituted for the words "Director" or "Department" as specified in the State of Ohio, Department of Transportation, Construction and Materials Specifications. The word "WCTID" shall also mean "Owner."

III 100.2 Engineer - Whenever the word "Engineer" is used, it shall be held to mean the County Engineer of Warren County, the Engineer's Deputy, Project Supervisor, or Inspectors delegated by the Engineer to supervise or inspect the Work. The same interpretation shall apply to the word 'engineer' as used in the State of Ohio, Department of Transportation, Construction and Materials Specifications.

III 100.3 Bidder - An individual, firm, or corporation submitting a bid for the advertised Work, acting directly or through the duly authorized representative, and qualified as provided in the Ohio Revised Code.

III 100.4 County - Shall, at all times, mean Warren County, Ohio.

III 100.5 Estimates - Payments to the Contractor for Work, labor, or materials whether partial or final payment.

SECTION III 200 PROVISIONS AND PROPOSALS

III 200.1 Plans - The official plans, profiles, typical cross-sections, general cross-sections, working drawings and supplemental drawings, or exact reproductions thereof, approved by the WCTID which show the location, character, dimensions and detail of the Work to be done, and which are to be considered as a part of the contract supplementary to these specifications.

III 200.2 Special Provisions - Specific clauses included hereafter setting forth conditions or requirements peculiar to the project under consideration and covering Work or materials involved in the proposal and estimate but not satisfactorily covered by the general specifications. **Note: All Special Provisions (Technical Specifications) can be found on the corresponding Construction Drawings included as part of this bid package.**

III 200.3 Supplemental Agreements - Written agreements executed by the WCTID covering alterations necessary to the project as herein after provided.

III 200.4 Delivery of Proposal - The proposals for the Project shall be placed together with the proposal guaranty, in a sealed envelope so marked as to indicate the identity of the Project and the name and address of the Bidder. If forwarded by mail, said envelope shall then be placed in another envelope which shall be sealed and addressed as indicated in the "Notice to Contractors." The proposal will be received until the hour and date set for the opening thereof and must be in the hands of the WCTID by such time. Proposals received after the time set for receiving bids and/or opening bids shall be returned to the Bidder unopened.

III 200.5 Proposal Guaranty - Each Bidder is required to submit with its proposal a Bid Guaranty and Contract Bond in accordance with Section 153.571 of the Ohio Revised Code which specifies that each proposal must be accompanied by a bond in the sum of one-hundred (100) percent (%) of the amount bid or a certified check, cashier's check or irrevocable letter of credit in the sum of ten (10) percent (%) of the amount bid as a guarantee that, if the proposal is accepted, a contract shall be entered into. If a check is filed, it shall be made payable to The Warren County Transportation Improvement District. If a surety bond is posted, it shall be made out to The Warren County Transportation Improvement District.

III 200.6 Proposal Withdrawal - A Bidder may withdraw its proposal, provided the request in writing is in the hands of the WCTID before the time set for opening proposals. When such proposal is withdrawn it will be returned to the Bidder unopened.

III 200.7 Public Opening of Proposals - Proposals will be opened and read publicly at the time and place designated by the WCTID. Bidders, their authorized agents, and the public are invited.

III 200.8 Consideration of Proposals - After the proposals are opened and read, they will be compared on the basis, if a unit price proposal, of the summation of the products of the approximate quantities shown in the proposal by the unit bid prices. In event of a discrepancy between unit bid prices and extensions thereof, the unit price bid shall govern. In the event lump sum items are included in the proposal, the final correct total of the proposal, after all unit price corrections are made, if any, shall govern. The WCTID will consider all properly submitted proposals, reserves the right to reject any and all bids, and if a Contract is awarded, may award it to the lowest and best Bidder.

III 200.9 Disqualification of Bidders - Not more than one proposal from an individual, a firm or partnership, a corporation or an association under the same or different names, will be considered for one project. Reasonable ground for believing that any Bidder is interested in more than one proposal for the Work contemplated shall cause the rejection of all proposals in which the Bidder is interested. The Bidder shall make a non-collusion affidavit, which is properly executed and part of the proposal. Proposals in which the prices obviously are unbalanced may be rejected. Contracts will be awarded only to responsible Bidders capable of performing the class of work contemplated. The WCTID reserves the right to reject any or all bids.

III 200.10 Materials and Workmanship - Any additional items required, including labor, equipment, and/or materials, but not listed as a separate pay item in the proposal, shall be furnished, installed, removed etc. as incidental to the contract, except where noted on the plans and in the specifications.

III 200.11 No Waiver of Legal Rights - Neither the inspection by the WCTID and/or Engineer or by any of their duly authorized agents, nor any order, measurement, or certificate by the Engineer, or said agents, nor any order by the WCTID and/or Engineer for the payment of money, nor any payment for, nor acceptance of, any Work by the WCTID and/or Engineer, nor any extension of time, nor any possession taken by the WCTID or its duly authorized agents, shall operate as a waiver of any provision of this Contract, or of any power herein reserved to the WCTID, or any right to damages herein provided; nor shall any waiver by WCTID or the Engineer of any breach of this Contract be held to be a waiver of any other or subsequent breach.

II 200.12 Laws to be Observed - The Contractor warrants that it is familiar with and agrees at all times to comply with the provisions of all Federal and State laws and ordinances and regulations of all political subdivisions, of the Workman's Compensation Laws, ordinances and regulations in any manner affecting the conduct of the Work and it shall defend, indemnify, and save harmless the WCTID and

Warren County, Ohio and its representatives against any claims arising from the violation of any such law, ordinance or regulation, either by the Contractor or its agents, servants or employees or the negligence of such Contractor, agent, servant or employee.

II 200.13 Home Office Overhead Calculations – ODOT Specification 109.05.D.2.f is specifically excluded from incorporation into the Contract. In the event of a compensable delay for which Contractor seeks to recover its unabsorbed Home Office Overhead expenses, Contractor and the WCTID agree that the HOOPS formula is not an appropriate or accurate measurement of such damages under the Contract and that the Eichleay Formula is the sole measure of such allowable damages provided that Contractor can prove entitlement to such damages under the Eichleay formula as applied by the Courts of Ohio.

SECTION 300 CONTRACTS

III 300.1 Requirements of Contract Performance Bond – Provided that the successful Bidder has not previously submitted a combined Bid Guaranty and Contract Bond with the Bid Proposal, the successful Bidder must, within ten (10) days after the award to him, and before entering into contract, furnish a bond in form consistent with the requirements of Section 153.54 and related sections of the Ohio Revised Code, to the approval of, and of the form prescribed by the WCTID, in an amount equal to one-hundred (100) percent (%) of the full amount of the bid. Said Performance Bond shall have a date of validity until "final payment" is deposited with the Contractor or until a later date as required.

III 300.2 Execution of Contract - The Contract shall be signed by the successful Bidder and returned, together with the performance bond, if applicable, within ten (10) days after the Bidder has received notice that the Contract has been awarded. No proposal shall be considered binding upon the WCTID until the execution of the Contract and performance bond.

III 300.3 Failure to Execute Contract - Failure to execute and file an acceptable performance bond, if applicable, and as provided herein within ten (10) days from date of award shall be just cause for the annulment of the award and the forfeiture of the bid guaranty to WCTID, not as a penalty, but as liquidated damages. Award may then be made to the next lowest and best Bidder in the sole discretion of the WCTID or the Work may be readvertised, as solely determined by the WCTID. Said forfeiture shall be guided by the provisions of Section 153.54 of the Ohio Revised Code.

III 300.4 Lump Sum Contract - If the Work is let on the basis of a lump sum contract, the estimated quantities of Work are only approximate, although the result of calculations, and the Bidder must obtain and be responsible for the data upon which it based its bid. It shall not be entitled to any additional compensation in case the quantities of Work actually done to fulfill the contract and complete the project are greater than said estimate quantities, and assumes all risks for any mistakes in calculations.

III 300.5 Specifications Governing This Project - The terms and conditions of the Contract Documents will govern this Project, including but not limited to these general provisions, provisions set forth in any proposal notes, and the 2023 "ODOT Specifications" (the State of Ohio Department of Transportation Construction and Materials Specifications effective January 1, 2023 its revisions and supplements). WCTID will be substituted where the specification refers to the Director. Notwithstanding the foregoing, the following ODOT Specifications are specifically excluded from this Contract:

III 300.5.1 Excluded ODOT Specifications: Section 102.01, 102.03, 102.06, 102.09, 102.10, 102.11, 102.14, 103.01, 103.02, 103.04, 103.06, 103.07, 104.02, 105.05, 105.13, 107.04, 107.13, 108.01, 108.02 (A), 108.06 (D), 108.08, 108.09, 109.05(D), 109.06, 109.09, 109.10, 109.12 (A) 109.12 (B), 109.12 (C), 109.12 (D), 109.12 (E), 401.20.

III 300.5.2 Interpretation/Precedence - It is intended that the specifications governing this project (and any bidding requirements and conditions) and any ODOT specifications or references to the Ohio Revised code as set forth herein, and any attachment(s) or documents incorporated by reference herein, be construed harmoniously wherever possible in order to carry out the full intent and purposes of the WCTID with respect to

this project. But if there is a conflict or inconsistency between any provision(s) of the ODOT specifications or references to the Ohio Revised Code and those contained herein, the provision(s) granting greater rights or remedies to the WCTID, or imposing the greater duty, standard, responsibility or obligation on the Contractor shall govern.

III 300.6 Federal Requirements - During the performance of the Contract, Contractor for itself, its assignees and successors in interest agrees as follows:

III 300.6.1 The Contractor will ensure that applicants are hired and that employees are treated during employment without regard to their race, religion, color, sex, national origin (ancestry), disability, genetic information, age (40 years or older), sexual orientation, or military status (past, present, or future). Such action shall include, but not be limited to, the following: Employment, Upgrading, Demotion, or Transfer; Recruitment or Recruitment Advertising; Layoff or Termination; Rates of Pay or other forms of Compensation; and Selection for Training including Apprenticeship.

III 300.6.2 The Contractor agrees to post in conspicuous places, available to employees and applicants for employment, notices setting forth the provisions of this nondiscrimination clause. The Contractor will, in all solicitations or advertisements for employees placed by or on behalf of Contractor, state that all qualified applicants will receive consideration for employment without regard to race, religion, color, sex, national origin (ancestry), disability, genetic information, age (40 years or older), sexual orientation, or military status (past, present, or future).

III 300.6.3 Compliance with Regulations: The Contractor (hereinafter includes consultants) will comply with the Acts and Regulations relative to Non-discrimination in Federally-assisted programs of the U.S. Department of Transportation, Federal Highway Administration (FHWS), as they may be amended from time to time, which are herein incorporated by reference and made a part of this contract.

III 300.6.4 Nondiscrimination: The Contractor, with regard to the work performed by it during the contract, will not discriminate on the grounds of race, color, national origin (ancestry), sex, age (40 years or older), disability, low-income status, or limited English proficiency in the selection and retention of subcontractors, including procurements of materials and leases of equipment. The Contractor will not participate directly or indirectly in the discrimination prohibited by the Acts and the Regulations as set forth in subsection I.300.6.9 herein, including employment practices when the contract covers any activity, project, or program set forth in Appendix B of 49 CFR Part 21.

III 300.6.5 Solicitations for the Contractor, including Procurements of Materials and Equipment: In all solicitations, either by competitive bidding, or negotiation made by the Contractor for work to be performed under a subcontract, including procurements of materials, or leases of equipment, each potential contractor or supplier will be notified by the Contractor of the Contractor's obligations under this Agreement and the Acts and the Regulations relative to nondiscrimination on the grounds of race, color, national origin (ancestry), sex, age (40 years or older), disability, low-income status, or limited English proficiency.

III 300.6.6 Information and Reports: The Contractor will provide all information and reports required by the Acts, the Regulations, and directives issued pursuant thereto, and will permit access to its books, records, accounts, other sources of information, and its facilities as may be determined by the WCTID, ODOT or FHWA to be pertinent to ascertain compliance with such Acts, Regulations, and instructions. Where any information required of a Contractor is in the exclusive possession of another who fails or refuses to furnish this information, the Contractor will so certify to the WCTID, ODOT or FHWA, as appropriate, and will set forth what efforts it has made to obtain the information.

III 300.6.7 Sanctions for Noncompliance: In the event of the Contractor's noncompliance with the nondiscrimination provisions of this agreement, WCTID will impose such contract sanctions as it, ODOT, or FHWA may determine to be appropriate, including, but not limited to:

A. Withholding of payments to the Contractor under the Agreement until the Contractor complies, and/or

B. Cancellation, termination or suspension of the Agreement, in whole or in part.

III 300.6.8 Incorporation of Provisions: Contractor must include the provisions of the above subparagraphs III.300.6.1 through III.300.6.6 in every subcontract, including procurements of materials and leases of equipment, unless exempt by the Acts, the Regulations, and directives issued pursuant thereto. The Contractor will take action with respect to any subcontract or procurement as the WCTID, ODOT or FHWA may direct as a means of enforcing such provisions including sanctions for noncompliance. Provided, that if the Contractor becomes involved in, or is threatened with litigation by a subcontractor or supplier because of such direction, the Contractor may request the WCTID to enter into any litigation to protect the interests of the WCTID. In addition, the Contractor may request the United States to enter into the litigation to protect the interests of the United States.

III 300.6.9 Pertinent Non-Discrimination Authorities. During the performance of this Agreement, the Contractor, for itself, its assignees, and successors in interest agrees to comply with the following non-discrimination statutes and authorities; including but not limited to:

- A. Title VI of the Civil Rights Act of 1964 (42 U.S.C. § 2000d et seq., 78 stat. 252) (prohibits discrimination on the basis of race, color, national origin); and 49 CFR Part 21;
- B. The Uniform Relocation Assistance and Real Property Acquisition Policies Act of 1970 (42 U.S.C. § 4601) (prohibits unfair treatment of persons displaced or whose property has been acquired because of Federal or Federal-Aid programs and projects);
- C. Federal-Aid Highway Act of 1973 (23 U.S.C. § 324 et seq.) (prohibits discrimination on the basis of sex);
- D. Section 504 of the Rehabilitation Act of 1973 (29 U.S.C. § 794 et seq.), as amended (prohibits discrimination on the basis of disability) and 49 CFR Part 27;
- E. The Age Discrimination Act of 1975, as amended (42 U.S.C. § 6101 et seq.) (prohibits discrimination on the basis of age);
- F. Airport and Airway Improvement Act of 1982 (49 U.S.C. § 471, Section 47123), as amended (prohibits discrimination based on race, creed, color, national origin, or sex);
- G. The Civil Rights Restoration Act of 1987 (PL 100-209) (broadened the scope, coverage, and applicability of Title VI of the Civil Rights Act of 1964, the Age Discrimination Act of 1975, and Section 504 of the Rehabilitation Act of 1973, by expanding the definition of the terms "programs or activities" to include all of the programs or activities of Federal-Aid recipients, sub-recipients, and Contractors, whether such programs or activities are Federally funded or not);
- H. Titles II and III of the Americans with Disabilities Act (42 U.S.C. §§ 12131-12189), as implemented by Department of Transportation regulations at 49 CFR parts 37 and 38 (prohibits discrimination on the basis of disability in the operation of public entities,

public and private transportation systems, places of public accommodation, and certain testing entities)

- I. The Federal Aviation Administration's Non-Discrimination Statute (49 U.S.C. § 47123) (prohibits discrimination on the basis of race, color, national origin, and sex)
- J. Executive Order 12898, Federal Actions to Address Environmental Justice in Minority Populations and Low-Income Populations (ensures non-discrimination against minority populations by discouraging programs, policies, and activities with disproportionately high and adverse human health or environmental effects on minority and low-income populations)
- K. Executive Order 13166, Improving Access to Services for People with Limited English Proficiency, and resulting agency guidance, national origin discrimination includes discrimination because of limited English proficiency (LEP). To ensure compliance with Title VI, you must take reasonable steps to ensure that LEP persons have meaningful access to your programs (70 Fed. Reg. at 74087 to 74100);
- L. Title VIII of the Civil Rights Act of 1968 (Fair Housing Act), as amended (prohibits discrimination in the sale, rental, and financing of dwellings on the basis of race, color, religion, sex, national origin, disability, or familial status (presence of child under the age of 18 and pregnant women)
- M. Title IX of the Education Amendments Act of 1972, as amended (20 U.S.C. 1681 et seq.) (prohibits discrimination on the basis of sex in education programs or activities);
- N. Uniformed Services Employment and Reemployment Rights Act of 1994 (USERRA 38 U.S.C. 4301-4335) (prohibits discrimination on the basis of present, past or future military service)

III 300.7 Entire Agreement. The Contract Documents contain the entire agreement between Contractor and WCTID, and no oral statements or prior written matter not specifically incorporated therein shall be of any force or effect. The Contract may not be modified except by a written document executed by both parties thereto.

SECTION III 400 *WCTID and ENGINEER, WORK, AND PLANS*

III 400.1 Authority of Engineer - The Engineer, in consultation with the WCTID: (a) has immediate charge of the engineering details of the Project; (b) is responsible for the administration and satisfactory completion of the Project; and (c) has the authority to reject defective material and to suspend any Work that is being improperly performed.

III 400.2 Errors and Omissions - The WCTID reserves the right, in consultation with the Engineer, to correct by change order any errors or omissions in said plans or specifications wherever such correction is necessary for the proper fulfillment of the intention of the plans or specifications.

III 400.3 Interpretation of Estimates - The quantities listed in the Bid Proposal form(s) are to be considered as approximate and are to be used for the comparison of bids only. The unit prices to be tendered by the Bidder are to be tendered expressly for the scheduled quantities which later may be increased or decreased within the restricting limits herein after stipulated. Where there is a conflict between the unit price and the extension thereof made by the Bidder, the unit price shall govern and the WCTID and/or Engineer shall be authorized to make a correct extension of such unit bid price and to use such corrected extension in comparing bids.

III 400.4 Pre-Construction Meeting - After the award of the Contract and before beginning any Work, the Contractor and its superintendent, shall meet with the Engineer for a pre-construction meeting, to review all restrictions and regulations governing the Work. Any schedules, requests, papers,

approvals, submittals, changes, etc. as called for in the Contract Documents shall be made at this time unless otherwise directed.

III 400.5 Use of Premises - The Contractor shall confine its equipment, tools, the storing of materials, and the operation of its workmen within the right-of-way and/or Work limits as approved by the Engineer. It is emphasized that damage to vegetation, especially trees, shall be held to an absolute minimum.

III 400.6 Dust, Water Pollution, and Erosion Control - The Contractor shall be responsible for complying with the Water Management and Sediment Control Regulations of Warren County that are in effect at the date of letting. The Contractor shall employ measures to prevent or control spills of fuels or lubricants from entering the waters of the state and submit a contingency plan to the Engineer to be effective in the event of a spill. Dust shall be kept to a minimum.

III 400.7 Coordination of Plans, Specifications, and Special Provisions - The specifications, plans, special provisions, and all supplementary documents are essential parts of the Contract and a requirement appearing in one is as binding as though in all. In case of a discrepancy, unless otherwise directed by the WCTID or Engineer, figured dimensions shall govern over scaled dimensions and special provisions shall govern over both specifications and plans.

SECTION III 500 PROGRESS OF WORK AND QUANTITIES

III 500.1 Extra Work - Unforeseen or other work made necessary by minor alterations of the plans, or necessary to complete the proposed improvement contract, shall be deemed extra and shall be performed by the Contractor in accordance with the specifications and as directed; provided, however, that before any extra Work is started, the Contractor has been authorized by the Engineer in writing to do the extra Work. When the nature of the extra Work required is such that the exact amount of the extra Work cannot be determined precisely, the Contractor shall proceed only when authorized to do so by the Engineer.

III 500.2 Incidental Work at Contractor's Expense - All Work done by the Contractor, specified or mentioned in the plans or specifications, as well as any minor details of Work not specifically mentioned but obviously necessary for the proper completion of the Work, shall be considered as incidental, and as being part of any included in the Contract. The Contractor will not be entitled to any extra or additional compensation for the same.

III 500.3 Increased or Decreased Quantities - The WCTID reserves the right to make such alterations in the plans or in the quantities of the Work as may be considered necessary or desirable, and no conditions or provisions of the Contract shall be ordered in writing and that equitable adjustment of compensation shall be agreed upon; provided further that before the Work is started on any such alteration at the opinion of the WCTID a Supplemental Agreement setting forth the adjustment shall be executed by the WCTID and the Contractor. The Contractor shall perform the Work as increased or decreased and compensation for materials shall be adjusted per unit price bid.

III 500.3.1 All change orders shall be in writing. The WCTID shall not pay any increase in expense, and Contractor agrees that it waives all right to payment for extras or otherwise valid claims for extras or change order Work performed without first (a) complying with the notice provisions set forth in the Contract Documents and (b) obtaining a prior approved change order.

III 500.3.2 Unit Prices for Remediation of hazardous materials. Contractor acknowledges that the Work for the WCTID under this Contract may involve the risk of encountering petroleum contaminated soils (PCS) or other hazardous materials during construction excavation and other work. Contractor agrees and represents that the nature of the Contract Work is such that any soil borings or similar analysis by WCTID or its Engineer or consultants may not indicate the complete and full amount of contaminated soils and that Contractor may encounter more extensive or additional PCS or other hazardous materials contamination during construction excavation than indicated in any soil borings or other tests. Contractor

represents that its unit price bid for any remediation work involving hazardous materials includes all costs and considerations arising out of or relating to the Work involved, including the cost of schedule impacts as a whole, all delay-related costs (including but not limited to extended home office overhead, extended field conditions, extended site conditions, labor) and all costs to excavate, store, test, transport, and dispose of contaminated materials. The original Contract unit price shall thus cover all expenses and impacts associated with remediation and handling of both the contaminated soils identified in any environmental studies plus those actually discovered during construction. Contractor's payment for any required remediation work thus shall be at the original Contract unit price for the agreed quantities of the work in question and shall constitute full and final reimbursement of Contractor for the work and settlement of all claims arising out of or pertaining to the Work regardless of whether the Contract items vary in any respect from the estimated quantities. Notwithstanding the foregoing, WCTID has sole discretion to determine that an original Contract unit price would not be fair to WCTID or result in a windfall to Contractor, and may by notice to Contractor enter into negotiations over a reasonable price for excess contract Work involving contaminated soils.

III 500.4 Claims and Notice - Contractor shall submit to WCTID and Engineer any requests or claims for adjustment in the Contract Price, Time, or other provisions of the Contract for changes directed by the Owner, as a result of deficiencies or discrepancies in the Contract Documents, for unforeseen causes, unanticipated site conditions, and for any other circumstance otherwise permitted by law or the Contract Documents within five (5) days of the act or occurrence giving rise to the claim and before Contractor proceeds to perform any extra Work and seek a confirmation of receipt from WCTID and Engineer. Within ten days after providing such written notice, Contractor shall submit a written statement to the owner setting forth in detail: (1) the nature and cause of the claim and the specific provision of this Contract which support such claim; (2) specific references to the details of the Drawings and any Specifications that are affected by the claim; and (3) an itemized and substantiated statement of the amount of the claim, or of the time extension support by such documentation as the Owner may reasonably request. Failure to provide such notice and said confirmation procedure within the five day period, or to comply with said written statement procedures within the ten day period, shall constitute Contractor's waiver of the right to compensation or time for the act or occurrence in question. Any increase in the Contract price, or extension in the Contract Time resulting from such claim or change may only be effected by an authorized written Change Order signed by WCTID.

III 500.5 Certification of Claims and Written Statement. All written statements (as set forth above in 500.4) and claims made by Contractor, or by any subcontractor or supplier of any tier through Contractor, shall be accompanied by a sworn and notarized certification by the designated representative of Contractor having overall responsibility for Contractor's affairs, stating: (1) the claim is made in good faith; (2) the supporting data are accurate and complete to the best of Contractor's knowledge and belief; (3) the amount requested accurately reflects the Contract adjustment for which Contractor believes the WCTID is liable. For subcontractor claims Contractor may not rely on subcontractor certifications but must conduct an evaluation reasonably sufficient to certify the claim as stated above. Contractor's certification of a false or inaccurate claim will entitle WCTID to recover its costs of investigating, evaluating, and defending such including but not limited to attorney, accountant and expert fees, from Contractor and/or the individual certifying the claim. Failure to provide a full and complete Certification required at the time the claim or written statement is provided shall constitute Contractor's waiver of the right to the relief it has requested but failed to properly or timely certify.

III 500.6 Date of Completion - The Contractor shall have completed the Work, or any portion thereof, on or before the calendar date and/or time period specified in the Contract Documents, including any interim completion dates or milestones. Otherwise the WCTID may proceed per Sections 500.7 and 500.8 of these Specifications. If the Contract is revised in any material respect and it is determined that said revision will cause delay in the completion of the Work, the WCTID shall postpone the completion date by the number of calendar days they determine.

III 500.6.1 Delays for Cause. When delay occurs due to unforeseen causes beyond the control and without the fault or negligence of the Contractor, including but not restricted to calamities,

force majeure, acts of the public enemy, acts of Government, acts of the State or any political subdivision thereof, fires, floods, epidemics, pandemics, strikes, except those caused by improper acts or omissions of the Contractor, extra ordinary delays in delivery of materials caused by strikes, lockouts, wrecks, freight embargoes (acts of Government) or calamities, the time of completion shall be extended in whatever amounts determined by the WCTID to be equitable, provided notice and certification has been given as required above. This provision shall become effective only if the Party failing to perform notifies the other party within a reasonable time of the extent and nature of the Force Majeure Event, limits delays to those required by the Event, and takes all reasonable steps to minimize damages and resume performance.

III 500.6.1.1 A “**Calamity**” is construed to mean an earthquake, flood, cloud burst, cyclone, or other cataclysmic phenomenon of nature beyond the power of the Contractor to foresee or to make allowances for.

III 500.6.1.2 “**Force Majeure**” is construed to mean events including but not limited to, civil disturbances, armed conflict or the serious threat of the same (including but not limited to hostile attack, blockade, military embargo); act of terrorism, sabotage or piracy; plague, epidemic, pandemic, outbreaks of infectious disease or any other public health crisis, including quarantine or other employee restrictions; act of authority whether lawful or unlawful, compliance with any law or governmental order, rule, regulation or direction, curfew restriction, expropriation, compulsory acquisition and/or seizure of works.

III 500.6.1.3 Delays and Time Extensions when the proximate cause is the act or inaction of the WCTID. If the Contractor is delayed in the progress of the Work by causes reasonably beyond its control and through no fault of its own, where the proximate cause of the delay is the WCTID’s actions or inactions (within the meaning of ORC §4113.62(C)(2)), the Contractor shall be entitled to a reasonable time extension and extended field general conditions in a reasonable amount as determined by the WCTID after consultation with its Consultant, Construction Manager, or Architect, if any. In addition, Home office overhead shall be allowable pursuant only to the Eichleay formula as applied by the Courts of Ohio and such unabsorbed home office overhead shall (a) be based on business days lost to the critical path of the Project and (B) only be allowed if the cumulative delay in question to the critical path exceeds fourteen (14) days. Contractor represents and agrees that any such extension of time, extended field general conditions, and Eichleay Damages shall be the Contractor’s sole remedy and measure of “delay damages” and Contractor represents as a material inducement to WCTID to enter this Contract, that Contractor shall not be entitled to any additional compensation for any other damages allegedly arising out of or relating to the delay in question, including but not limited to, any additional fees, costs of acceleration, consequential damages, loss of efficiency, loss of productivity, lost opportunity costs, impact damages, lost profits or other similar remuneration.

III 500.6.2 No time extensions will be granted for any delay or suspension of the Work due to fault of the Contractor.

III 500.6.3 Postponement of the completion date shall be immediately recorded by the appropriate journal entry by the WCTID and the Contractor formally advised. If the WCTID should suspend the Work in whole or in part as provided in Section 500.8 of these specifications, the date of completion shall be extended the number of days that the suspension directly or indirectly delays completion of the Work.

III 500.6.4 If the WCTID for any reason extends the completion date, the extension of time shall not relieve the bond annexed this agreement or the sureties thereon from any of the obligations therein expressed.

III 500.6.5 If the Contractor files any bankruptcy related action such as Chapter 7 or Chapter 11 or placed in receivership, the WCTID may terminate this Contract and seek alternative completion, may seek to make a claim on any performance bond, or take any other action it deems necessary or prudent to timely complete the Work. The Contractor will be not be entitled to any payment for Work completed to date until such time as the Project is finally complete. At that point, Contractor shall be entitled to payment for Work completed at the time of its termination less any damages or expenses incurred by the WCTID in re-soliciting the project, awarding it elsewhere, or completing it itself (the "Completion Damages"). If the Completion Damages exceed the balance on the Contract left at the time of the termination (including amounts due Contractor for its Work completed to date), Contractor shall be responsible for paying the difference to the WCTID. Otherwise, the WCTID shall pay the Contractor for Work completed to date less the WCTID's damages.

III 500.6.6 Coordination Responsibilities. The parties understand and agree that if the Work or any portion thereof involves work of or coordination with any public utilities, telecommunication providers or railroad companies or entities responsible for any necessary utility relocation, telecommunication facilities, railroad coordination, or electrical service installation or any similar services required during the construction to complete the construction within the Contract times for Date of Completion, the Contractor assumes responsibility for such coordination and any delays resulting therefrom. Any Contractor costs for such shall be incorporated into the line item and/or profit and overhead markups incorporated into the Contract and the time for same shall be considered incorporated into Contractor's obligation to complete within the Contract times for Date of Completion. To the extent reasonable the WCTID will assist Contractor in facilitating such coordination, but such assistance shall not relieve the Contractor of its obligations hereunder. The WCTID will coordinate with and obtain approval by ODOT and/or the Engineer, as may be appropriate or required, for any necessary traffic signal or roadway design elements of the construction. Contractor shall be responsible to coordinate any inspections or approvals necessary to be obtained from ODOT and/or the Engineer, as may be appropriate or required, for the Work during construction.

III 500.7 WCTID to Complete Work In Case of Failure - If in the opinion of the WCTID, the Contractor has not commenced the Work, within a reasonable time or does not carry the same forward with reasonable progress, or is improperly performing the Work or any portion thereof, or has abandoned or fails or refuses to complete the Work under the provisions of these specifications and the Contract, said WCTID shall have full power and authority to enter upon and construct said improvement or any part thereof either by Contract, force account, or in such manner as it may deem for the best interest of the public; paying in full costs and expenses thereof from the balance of the Contract price unpaid to the Contractor. In case there is insufficient balance to pay for the Work, the WCTID shall require the Contractor, or the surety on its bond, to pay the cost of completing the Work.

III 500.7.1 The WCTID shall withhold estimates, or partial estimates, that may be due the Contractor for Work performed to date, until it has fulfilled all the provisions mentioned above the extension of time.

III 500.7.2 If the conditions beyond the control of the WCTID or Contractor prevent the completion of the project, such as (but not limited to) changes in the law, EPA regulations, catastrophe or court order, then the WCTID may, in its discretion, pro-rate and cancel the project.

Any materials purchased but not utilized shall be paid for by and become property of the WCTID.

III 500.8 Failure to Complete by Specified Date - Time is of the essence of this Contract. The parties hereto acknowledge that the WCTID is entitled to full use of the completed Work, or any portion thereof as applicable to any interim completion dates or milestones, following expiration of the Contract Time for such Work, and that if the Contractor fails to complete the Contract or any portion thereof on or before any such contractually specified completion date the WCTID will sustain extensive damage and serious loss as a result. The exact amount of such damages will be extremely difficult to establish and calculate with certainty. Thus, the WCTID and Contractor agree that if the Contractor fails to complete the Work or any portion thereof or before the date agreed upon as mentioned elsewhere in the Contract, or before the interim, milestone, or substantial completion or Date of Completion agreed upon as mentioned elsewhere in the Contract the WCTID shall be entitled to retain or recover from the Contractor, as liquidated damages and not as a penalty, the per diem amounts set forth in the 2019 ODOT CMS Table 108.07-1 SCHEDULE OF LIQUIDATED DAMAGES (the "2019 ODOT CMS Schedule of Liquidated Damages"), commencing upon the first day following expiration of the Contract time or interim completion date or milestone, as appropriate and continuing until the actual date of substantial completion. Contractor and the WCTID agree that such liquidated damages are a reasonable pre-estimate of damages the WCTID will incur because of delayed completion of the Work.

III 500.8.1 The WCTID may deduct liquidated damages described above from any unpaid amounts then or thereafter-due Contractor under the Contract. Any liquidated damages not so deducted from any unpaid amounts due the Contractor shall be payable to the WCTID upon demand.

III 500.8.2 The liquidated damages set forth herein shall be WCTID's exclusive damage remedy for Contractor's failure to complete the Work on or before the date of substantial completion or interim completion date or milestone, but such liquidated damages shall in no way limit Owner's entitlement to damages for any other injury, damage, or loss, other than for delay, for which Contractor may be responsible pursuant to the terms of this Agreement or applicable law.

III 500.9 Suspension of Work - For such a period as is necessary or during such time the weather is unsuitable for proceeding with the Work, the WCTID may suspend Work, at places or altogether, if in its opinion, public need requires it. In case of such suspension during a working season, the time within which the Contractor is required to complete the Work shall be extended by as many days as the same was suspended. Upon any stoppage of the Work, all material shall be safely placed, so as to not obstruct or impede travel on the right-of-way.

III 500.10 Order and Progress of Work - The Work under this Contract shall be prosecuted at as many different places, at such times in such sections along the improvement and with such forces as the Engineer may direct. Completed portions of the roadway shall be opened to travel as directed by the Engineer, but shall not be construed as an acceptance of the Work done. Should the Work, for any reason, be discontinued by the Contractor, it shall, before again commencing the Work, give the Engineer notice of its intention at least twenty-four (24) hours in advance of commencement.

III 500.11 When Estimates May Be Withheld - Estimates may at any time be withheld or reduced if, in the opinion of the WCTID, the Work is not proceeding in accordance with the provisions of this contract; or if the Work is not progressing in proportion to the time spent working; or if the estimate is not in the same proportion to the entire contract price as the amount of the Work completed is to the entire Work.

III 500.12 Violations - At no time during the execution of this Contract shall the Contractor or any subcontractor violate any Federal, State, Municipal, Township, or local laws, statutes, regulations, ordinances, or resolutions.

III 500.13 Injunctions - If legal obstruction to the completion of the Work arises, and if the legal obstruction will cause delay in the completion of the Work, the WCTID may postpone the completion date by the number of calendar days they determine.

III 500.14 Termination for Cause. If the Contractor breaches any of its obligations under this Agreement, then WCTID may give Contractor written notification identifying such breach as a potential termination for cause. If Contractor has not cured such breach within seven (7) calendar days from its receipt of Owner's written notification, or if such breach cannot be cured within such seven (7) day period, then Owner may terminate this Contract for cause and take possession of the Work. Alternatively, instead of terminating the Contract, Owner may cure the breach and deduct the cost thereof from amounts otherwise owed to the Contractor.

1. Upon a termination for cause hereunder the WCTID may, without prejudice to any other rights or remedies it has:
 - a. Exclude the Contractor from the site and take possession of all materials, equipment, tools, and construction equipment and machinery thereon owned by the Contractor;
 - b. Request and accept assignment of subcontracts; and
 - c. Finish the Work by whatever method it deems expedient.
2. When the WCTID has terminated the Contract for cause the Contractor shall not be entitled to receive further payment until the Work is finished. If the unpaid balance of the Contract Sum exceeds the costs of completing the Work ("Completion Costs"), including but not limited to:
 - a. compensation for any additional design or architectural costs and expenses;
 - b. costs of rebidding and contracting for the completion of the Work; and
 - c. attorneys' fees and Architect's fees incurred arising out of or related to the termination and completion of the Work, such excess will be paid to the Contractor.
3. If the WCTID's Completion Costs exceed the unpaid balance, the Contractor shall pay the difference to the WCTID on demand. This obligation for payment shall survive termination of the Contract. When exercising any rights or remedies under this Section, the WCTID shall not be required to bid out or obtain the lowest price for the Work performed but shall in its discretion act in a commercially reasonable manner.
4. If a termination for cause hereunder is later determined or adjudged to be improper then such termination shall convert, and shall be accepted by the parties, to be a termination by WCTID for convenience subject to the terms and conditions set forth below. In such case the Contractor's sole right, remedy and recourse shall be determined by Section 500.15.

III 500.15 Termination for Convenience. The WCTID may terminate this Contract, in whole or in part, for WCTID's convenience and without cause if it determines, for any reason and in its sole discretion, that such termination is in its best interest. A Termination for Convenience hereunder shall be effected by delivery to the Bidder or Contractor of a Termination Notice specifying the extent to which the Contract is terminated and the date such termination becomes effective. If the Contract is terminated before performance is completed, the Contractor will be paid only for that work satisfactorily performed and in place for which costs can be substantiated based on the Contract value for the work in question. Such payment shall in no case exceed an amount which is the same percentage of the Contract Price as the amount of work satisfactorily performed.

III 500.16 Upon any termination of the Contract hereunder, all work in progress will become the property of the WCTID and will be turned over promptly by the Contractor after it has taken commercially reasonable steps to protect the work and any equipment or materials procured for prosecution of the Work.

SECTION III 600 CONTRACTOR INSURANCE REQUIREMENTS

The following types of insurance coverages and limits are required and shall be written for not less than the following, or greater if required by law and/or as otherwise specifically provided in the Contract or required by the WCTID as listed below. The WCTID, WCEO, Warren County, the Township of Union, Warren County, Ohio and their respective trustees, commissioners, officers, agents and employees are to be named as additional insureds with all rights under those policies unless otherwise determined by the WCTID.

III 600.1 Workmen's Compensation and Employers Liability as required by the laws of the State of Ohio.

III 600.2 The Contractor shall not commence Work under the Contract until it has obtained all the insurance required hereunder and has submitted, in quadruplicate, an appropriate Declaration of Insurance, as evidence of coverage which has been approved by the WCTID and concurred by the Engineer. The Contractor shall not allow any Subcontractor to commence Work on its subcontract until all similar insurance required by the Subcontractor has been so obtained and approved. Approval of the insurance by the WCTID shall not relieve or decrease the liability of the Contractor hereunder.

III 600.3 Contractor's Liability Insurance

III 600.3.1 The Contractor shall acquire and maintain during the term of the Contract Bodily Injury and Property Damage Liability Insurance under a standard Comprehensive General/Automobile Liability Policy which shall provide and include coverage on all Contractor's Operations, Protective (Sublet) Liability, Contractual Liability, Completed Operations Liability, Owned Automobiles and Non-Owned and Hired Automobiles.

III 600.3.2 Coverage for an "if any" basis: Property Damage Liability Insurance shall be provided on any demolition, blasting, excavating, shoring or similar operation on an "if any" basis.

III 600.3.3 Bodily Injury Liability limits shall be for an amount of no less than Two-Million **(\$2,000,000.00)** Dollars for injuries, including wrongful death to any one person and subject to the same limit for each person, in an amount of not less than Two-Million **(\$2,000,000.00)** Dollars on the account of any one occurrence.

III 600.3.4 Comprehensive Automobile Liability Insurance policy shall cover owned, non-owned, and hired vehicles with minimum limits as follows: Bodily Injury and Property Damage Liability Limit Each Occurrence **\$1,000,000**.

III 600.3.5 Property Damage Liability Insurance in an amount of not less than Two-Million **(\$2,000,000.00)** Dollars per occurrence with General Liability extended to provide "Broad Form Property Damage Liability" and in an amount of not less than Five-Million **(\$5,000,000.00)** Dollars aggregate for damage on account of all occurrences.

III 600.3.6 Any combination of underlying Comprehensive General/Automobile Liability coverage with Umbrella/Excess Liability coverage which provides **no less than** Five-Million **(\$5,000,000.00)** Dollars Single Limit Bodily Injury & Property Damage Liability Insurance for the Contractor will also be acceptable.

III 600.4 Project Protection. Until WCTID's final acceptance of the Work and Contractor's acceptance of final payment from WCTID for the Work, Contractor agrees that it is responsible to protect the Project, the Work, and/or the WCTID, WCEO, Warren County, Ohio, the Deerfield Township, Warren County, Ohio, and their respective boards, chairpersons, officers, trustees, commissioners, employers, members, agents, and volunteers from claims or loss incurred by fire, lightning, vandalism, theft, explosion and malicious mischief, and the risk of loss or any and all labor and materials connected with the Work (including materials delivered to the site but not yet installed). Contractor may, but is not required to, maintain insurance to cover the above risks as they pertain to the Project. Such insurance may include Contractor's Risk and/or Installation Floater insurance coverage, but its decision to obtain such insurance, or failure to do so, will not impact its obligations as set forth herein.

III 600.5 The Policies as listed in the paragraph's 600.1 through 600.4 shall all contain the following special provisions:

- * *The Contractor agrees that written notice will be mailed to the WCTID thirty (30) days prior to cancellation or reduction of the insurance afforded by this policy with respect to the Contract involved.*
- * *The Contractor shall submit evidence of such insurance to the WCTID with the executed contract in the form of a Certificate of Insurance, naming the Warren County Transportation Improvement District as the Certificate holder.*

III 600.5.1 The maintaining of such insurance as outlined herein shall in no way constitute a waiver of legal liability for damage to an adjoining property or their contents or the work of others.

III 600.5.2 Should any liability arise as a result of the action of the Contractor, subcontractors, or employees for which there is insufficient insurance coverage, the Contractor agrees to indemnify, defend, and hold the WCTID harmless from any liability or judgment (including reasonable attorneys fees and litigation expenses) and losses.

SECTION III 700 PAYMENTS, AND FINALITIES

III 700.1 Payroll Records - Payroll records kept in accordance with Section 4115.07, of the Ohio Revised Code and shall be open to inspection of authorized representatives or officials of WCTID. The contractor shall furnish the WCTID with an affidavit every thirty (30) days during the construction period stating that all employees and sub-contractors performing services on this project have been paid the prevailing rate of wages as certified by the Department of Industrial Relations provided by Chapter 4115 of the Revised Code of the State of Ohio.

III 700.2 Right of Direct Pay - The Contractor furnish upon the request of the WCTID prior to any partial payment(s) an affidavit listing money owed or paid to all subcontractors, laborers, or materialmen, and the WCTID, upon receipt of said affidavit, may, in its discretion, disburse appropriate sums owing as indicated directly to subcontractor's, materialmen, and laborers, with the balance being remitted to the Contractor.

III.700.3 Progress and Final Payment Releases - All applications for payment ("Pay Applications") shall be submitted in form acceptable to WCTID, shall include a complete description of the labor and materials supplied, and the work done during the period covered by the Pay Application (the "Pay Period"). As a condition precedent to Contractor's right to payment for Work performed, all Pay Applications shall be accompanied by (i) a list of all suppliers and subcontractors whose materials or services have been utilized by Contractor to perform the work described in the Pay Application, and (ii) a signed waiver of and release from any claims, on a form provided by or acceptable to the WCTID, that waives and releases all claims that could be asserted by Contractor for labor or materials performed during the Pay Period. Such waivers may be conditional on receipt of payment. Contractor agrees to furnish, if and when required by the WCTID, payroll affidavits, receipts, vouchers, releases of claims for labor, material and subcontractors performing work or furnishing material under this Agreement, all in form satisfactory to Owner. Pay Applications shall not be submitted more frequently than monthly, unless otherwise agreed in writing by the WCTID, and shall include all charges made since the preceding Pay Application Period.

III 700.4 Final Cleaning Up - Upon completion of the Work and before acceptance and final payments shall be made, the Contractor shall clean the roadway, borrow pits, stream channels and banks within the right-of-way at drainage structures, and all ground occupied by the Contractor in connection with the Work, of all rubbish, excess materials, false work, temporary structures and equipment, and all parts of the Work shall be left in a neat and presentable condition satisfactory to the Engineer. All land on which a temporary easement existed shall be returned to its preconstruction condition by the Contractor, the expense of which is included in the amount of this contract.

III 700.5 Final Inspection - Wherever the Work provided and contemplated by the Contractor has been satisfactorily completed and the final cleaning up performed, the Engineer shall, within ten (10) days, unless otherwise provided, make the final inspection.

III 700.6 Final Payments - The Engineer shall, as soon as possible after the completion of the entire Work, certify such completion to the WCTID, and the WCTID shall pay the entire sum so found to be due hereunder, after deducting therefrom all previous payments and all amounts to be kept and all amounts to be retained, under the provisions of this contract. All prior partial estimates and payments shall be subject to correction in the full settlement.

III 700.7 Payment of Total Costs to be Final Settlement of all Claims of the Contractor - The WCTID shall pay, and the Contractor shall receive, the sum herein stipulated as full compensation for everything furnished and done by the Contractor under this contract, including all incidental work required but not specifically mentioned, and also for all loss or damage arising out of the nature of the Work aforesaid, or from the action of the weather, or from any unforeseen obstruction or difficulty encountered in the prosecution of the Work, and for all risks of any description connected with the Work, and for all expenses incurred by or in consequence of the suspension or discontinuance of the Work, as herein specified, and for well and faithfully completing the Work, and whole thereof, as herein provided, together with remedying all defects developing during the period for which the Work is guaranteed. Final payment by the WCTID does not release the Contractor for any defects in construction, workmanship, or materials which could not have been ascertained by reasonable inspection.

III 700.8 Last Payment to be Final - Before the final estimate is allowed, the WCTID will require the Contractor to submit an affidavit showing that all claims and obligations arising in connection with the performance of the contract to include, but limited to, money owing to subcontractors, materialmen, or laborers have been satisfactorily settled. This requirement also includes an affidavit from any subcontractor(s) employed on the project. The acceptance by the Contractor of the last payment as aforesaid shall operate as and shall be a release to the WCTID and agents thereof for all claims and liability to the Contractor for anything done or furnished for, or relating to the Work, or for any act or neglect of the WCTID, or of any person relating to or affecting the Work.

III 700.9 Construction Funds Held in Trust. Contractor agrees that all funds it receives from WCTID for the performance of this Contract shall be held in trust by Contractor for the benefit of all its Subcontractors, suppliers, laborers, and materialmen, and Contractor shall not itself have any interest in such funds until all these obligations have been satisfied in full. Contractor further agrees that any funds received shall be used exclusively for the prosecution of the Project Work, and none will be diverted to satisfy other obligations of Contractor. WCTID does not have an obligation to pay or see to the payment of money to any subcontractor or supplier.

SECTION III 800 CLOSE-OUT PROCEDURE

III 800.1 When the Engineer and a Contractor determine the Work or a designated portion thereof is complete and acceptable in accordance with the Contract Documents, the Contractor shall submit a letter so stating to the Engineer, with a list of all incomplete items of Work and anticipated dates of completion for each.

III 800.2 Upon receipt of the letter claiming substantial completion of the Work, the Engineer will conduct an inspection. A list of items requiring completion or correction will be issued. If the Engineer approves the Contractor's claim of substantial completion, the Contractor will prepare a "Certificate of Substantial Completion" for acceptance by the WCTID and the Engineer. This Certificate will establish the Date of Substantial Completion.

III 800.3 When the Contractor has completed all items of Work on the "Completion and Corrections List" and is satisfied that all Work required by the Plans and Specifications for its contract Work has been completed, it shall submit its Final "Application for Payment" for all funds due and/or the retained percentage to the Engineer along with the following items:

- III 800.3.1 "Final Certification of Contractor" and "Consent of Surety" form.
- III 800.3.2 Affidavits as required by the Contract if required by the WCTID.
- III 800.3.3 Copies of test reports as may be required.
- III 800.3.4 Record Drawings or information as required by the Contract Documents for Record Drawings.
- III 800.3.5 Operating and Maintenance Instructions or Manuals required by the Contract Documents.
- III 800.3.6 Other data as required by governing bodies.
- III 800.3.7 Other submittals as required by the Technical Specifications such as Specific Guaranties, Warranties, Certificates, etc.

III 800.4 Upon receipt of the Contractor's Final Application and other required material, the Engineer shall verify its completeness and/or correctness. Incomplete or incorrect items shall be returned to the Contractor for corrections and resubmitted.

III 800.5 When the Engineer can certify that all Work under the Contract is complete and the Contractor has submitted all required items, it shall include the Contractor's Final Application on the "Final Certificate for Payment" and submit it to the WCTID.

III 800.6 The Engineer shall approve the "Final Certificate for Payment"; execute and forward three (3) copies to the WCTID. Any Contract or Contractor not receiving Engineer approval shall be deleted from the "Final Certificate for Payment."

III 800.7 The WCTID shall approve the "Final Certificate for Payment," deleting any unacceptable Contracts or Contractors, and return two (2) executed copies to the Engineer. Final checks shall then be distributed by the WCTID as required by the Contract Documents.

III 800.8 The Bid Guaranty shall not be released until final payment is deposited by the Contractor.

SECTION III 900 SAFETY

III 900.1 The Contractor will be responsible for initiating, maintaining, and supervising all safety precautions and programs in connection with the Work. It will take all necessary precautions for the safety of, and will provide the necessary protection to prevent damage, injury, or loss to all the Work and all materials or equipment to be incorporated therein, whether in storage on or off the site, and other property at the site or adjacent thereto, including trees, shrubs, lawns, walks, pavements, roadways, structures, and utilities not designated for removal, relocation, or replacement in the course of construction.

III 900.2 Contractor will erect and maintain, as required by the conditions and progress of the Work, all necessary safeguards for safety protection. It will notify owners of adjacent utilities when prosecution of the Work may affect them.

III 900.3 The Contractor shall maintain at its office or other well known place at the job site, all articles necessary for giving first aid to the injured, and shall make standing arrangements for the immediate removal to a hospital or a doctor's care of persons (including employees) who may be injured at the job site. In no case shall employees be permitted to work at a job site before the employer has made a standing arrangement for removal of injured persons to a hospital or a doctor's care.

III 900.4 Lights, signs and barricades shall be used to maintain traffic and safety for vehicular and pedestrian traffic during the course of this contract in accordance with the specifications.

III 900.5 The Contractor must have a Safety & Health Management Program in place and shall submit a copy of their Program to the Warren County Engineer's Safety/Risk Manager prior to the commencement of construction. The Program shall include, but shall not be limited to, management commitment, employee involvement, periodic work site surveys, hazards prevention, and control of safety and health education training (see 29 CFR 1926.20 for reference). In addition, prior to the commencement of construction, contractor shall designate a qualified and experienced safety representative at the site, whose duties and responsibilities shall be the prevention of accidents and the maintaining of supervising and safety precautions and programs.

SECTION III 1000 MISCELLANEOUS

III 1000.1 Permits. The Contractor is responsible for obtaining and paying for all necessary permits and licenses from the proper authorities. The Contractor shall give all notices and comply with all laws, ordinances, rules, and regulations bearing on the conduct of the work as drawn and specified. If the Contractor observes that the Contract Documents are at variance therewith, it shall promptly notify the Owner in writing.

III 1000.2 Course of Conduct. No course of conduct or dealing between the parties, nor express or implied acceptance of alterations or additions to the Work, and no claim that WCTID has been unjustly enriched by an alteration or addition to the Work, whether or not such unjust enrichment to the work or WCTID in fact exists, shall form the basis of any claim for an increase in the Contract Sum or any amount due under the Contract Documents, or a change in the Contract Time. Any claim not made in compliance with the provisions of the Contract, including but not limited to sections 500.4 and 500.5 herein, is waived.

III 1000.3 Disputes.

III 1000.3.1 - All claims, disputes, or other controversies between WCTID and Contractor arising out of or relating to the Contract or the breach thereof shall be decided by litigation in the Warren County Court of Common Pleas, which shall have exclusive jurisdiction to hear and determine any such claims, disputes, or other controversies.

III 1000.3.2 - The Contract shall be governed by the law of the State of Ohio, without regard to principles of conflicts of laws.

III 1000.3.3 - Notwithstanding any claim, dispute or other controversy between WCTID and Contractor, or between Contractor and its subcontractor(s), it shall be the responsibility of Contractor to continue to prosecute all of the Work and perform all of its services diligently and in a good and workmanlike manner in conformity with the Contract.

III 1000.3.4 In any litigation between WCTID and Contractor arising out of or relating to the Contract or the breach thereof, WCTID shall recover all reasonable attorneys fees and costs, court costs and fees, and expert witness fees and expenses incurred.

III 1000.4 Jointly Drafted - The parties acknowledge that each party and, if it so chooses, its counsel have reviewed this Contract and that the normal rule of construction to the effect that any ambiguities are to be resolved against the drafting party shall not be employed in the interpretation of this Contract and any amendments or exhibits thereto.

III 1000.5 Interest - Amounts due and unpaid Contractor under this Agreement shall accrue interest at the rate of three percent per annum, commencing sixty (60) days after such amounts were due.

III 1000.6 No third-party beneficiaries. Nothing in this Contract is intended, nor will be deemed, to confer rights or remedies upon any person or legal entity not a party to this Agreement.

III 1000.7 Severability - If any portion of this Contract is determined to be void, voidable or illegal, such portion shall be deemed severed from the other portions that are not void, voidable or illegal and (a) such other portions shall be enforceable in accordance with their terms; and (b) the severed provision shall be substituted by a valid provision which most closely approximates the intent and purpose of the severed provision and which would be enforceable to the maximum extent permitted by law.

III 1000.8 Reporting, Investigating, and Resolving Motorist Damage Claims. The Contractor is required to report, investigate, and resolve motorist damage claims according to 107.10 and 107.12 of the 2019 ODOT Specifications as follows. When a motorist reports damage to its vehicle either verbally or in writing to the Contractor, the Contractor shall within 3 days make and file a written report to the WCTID. If the WCTID directly receives a motorist's claim, it will, in its discretion, forward the claim report to the Contractor and/or the Contractor's insurance company to resolve. If the Contractor or its insurance company does not resolve the claim in a timely manner, the WCTID may advise the motorist of the option of pursuing the claim in the Ohio Courts. In the event of a lawsuit filed against the WCTID by the motorist, the WCTID, as co-insured party, may request the Contractor's insurance company to defend this lawsuit and hold the BCTID harmless according to the insurance requirements of this Contract. Any attorneys fees, court costs, litigation expenses, judgments, or settlement amount incurred by the WCTID arising out of any litigation or claims by a motorist hereunder will be assessed to the Contractor and deducted from the project, and notify Contractor of such action. If the Contract balance is insufficient to cover the extent of the backcharge,

III 1000.9 Warranty and Correction Period.

III 1000.9.1 Warranty - The Contractor fully warrants, for the benefit of the WCTID that all materials and equipment shall be new unless otherwise specified, of good quality, in conformance with the Contract Documents and free from defects in materials or workmanship.

III 1000.9.2 Correction Period. In addition to the Contractor's obligations under this Section 1000.8, if, within one year after the Date of Substantial Completion of the Work or after the date of commencement of the warranties hereunder (or such longer period of time as may be prescribed by the terms of any applicable special warranty or guarantee required by the Contract Documents), any of the Work is found not to be in accordance with the requirements of the Contract Documents, or if the repair of any damages to the land or any areas made available for Contractor's use in performing the Work is found to be defective, the Contractor shall, without cost to the WCTID, promptly correct or repair the damage, land, or defective work after receipt of written notice from the WCTID or Engineer. If the Contractor fails to correct or take steps to correct such defective or nonconforming work within seven (7) days after receipt of notice from the WCTID or Engineer, the WCTID may correct or repair the Work in question and all costs, claims, and damages arising out of or relating to such corrective action will be paid by Contractor to the WCTID on demand, including but not limited to, attorneys fees, and costs or charges of engineers, and other professionals, and all court or other dispute resolution costs).

SECTION III 1100 Drug-Free Workplace

1100.1 Selected Contractor and each subcontractor shall be enrolled and in good standing in the Drug-Free Workplace (DFWP) Program or a similar program approved by the Bureau of Worker's Compensation.

1100.2 The Contractor shall insert in each of its subcontracts a clause requiring all subcontractors to comply with this requirement.

SECTION IV

Federal and State Requirements [ODOT Local Let Project]

**ODOT's LPA Template (ODOT Spec Book and LPA Spec Book)
Required Contract Provisions.**

1. ODOT'S 2023 CONSTRUCTION AND MATERIAL SPECIFICATIONS (C&MS) AND ITS SUPPLEMENTS

ODOT's Construction and Material Specifications (C&MS) and its supplements are hereby incorporated by reference, in their entirety, as if rewritten herein. **The incorporation of this document by reference does not interfere with the order of precedence set forth in Section 105.04 of the C&MS Manual.**

In accordance with the Locally Administrated Transportation Projects Manual of Procedures (LATPM), when bidding this project, the contractor should replace the terms "the department", "the engineer", "the DCE" and "the DCA" with the term "the Local Public Agency (LPA)." Furthermore, nothing in this document is intended to alter the LPA's adherence to Ohio Revised Code, local ordinance or other applicable requirements which are properly established.

2. PN 100 FOR LPA PROJECTS (Not required, but strongly encouraged)

(PN 100 outlines general provisions to a construction contract. Local public agencies (LPAs) may choose to incorporate this document to include LPA specific preferences.

[2023 PN 100 for LPA Projects](#)

If including PN 100, download the template above. Green sections cannot be edited. Blue sections may be edited by the LPA. Yellow sections must have the LPAs own language incorporated. Once complete, insert the completed document in its entirety here. If not including PN 100, this item must be deleted from the bid doc template.)

3. PN 133 – 10/20/2023 – Products Made in the United States

The requirements of this note replace the domestic material requirements in 106.09 of the Construction & Material Specifications.

This note is automatically inserted into all projects that have federal funding in the construction phase or any prior phase. If there was federal participation in environmental studies, right of way acquisition, preliminary engineering or other phase defined in the environmental document, this note should be included in the proposal.

Furnish products that are made in the United States according to the applicable provisions of the Infrastructure Investment and Jobs Act, Pub. L. No. 117-58, which includes the Build America, Buy America Act Pub. L. 117-58, §§ 70901-52.

A. Federal Requirements. All steel or iron products incorporated permanently into the Work must be made of steel or iron produced in the United States and all subsequent manufacturing must be performed in the United States. Manufacturing is any process that modifies the chemical content; physical shape or size; or final finish of a product. Manufacturing begins with the initial melting and mixing and continues through the bending and coating stages. If a domestic product is taken out of the United States for any process, it becomes a foreign source material.

All manufactured products used in the project are not required to be produced in the United States.

All construction materials must be manufactured in the United States—this means that all manufacturing processes for the construction material occurred in the United States.

“Construction materials” includes an article, material, or supply—other than an item of primarily iron or steel; a manufactured product; cement and cementitious materials; aggregates such as stone, sand, or gravel; or aggregate binding agents or additives—that is or consists primarily of:

- Non-ferrous metals;
- Plastic and polymer-based products (including polyvinylchloride, composite building materials, and polymers used in fiber optic cables);
- Glass (including optic glass);
- Fiber optic cable (including drop cable);
- Optical fiber;
- Lumber;
- Engineered wood; and
- Drywall.

To provide clarity to item, product, and material manufacturers and processors, we note that items that consist of two or more of the listed materials that have been combined together through a manufacturing process, and items that include at least one of the listed materials combined with a material that is not listed through a manufacturing process, should be treated as manufactured products, rather than as construction materials. For example, a plastic framed sliding window should be treated as a manufactured product while plate glass should be treated as a construction material.

B. Exceptions. The Director may grant specific written permission to use non-domestic steel or iron products in any type of construction in accordance with 23 CFR 635.410(b)(4). The Director may grant such exceptions under the following condition:

- The cost of products to be used does not exceed 0.1 percent of the total Contract cost, or \$2,500, whichever is greater. The cost is the value of the product as delivered to the project.

The Director may grant specific written permission to use non-domestic construction materials and manufactured products in any type of construction in accordance with 2 CFR Part 184. The Director may grant such exceptions under the following conditions:

- The total value of the non-compliant products is no more than the lesser of \$1,000,000 or 5% of total applicable costs for the project; or
 - applicable costs are defined as the cost of materials (including the cost of any manufactured products) used in the project that are subject to a domestic preference requirement
 - the actual cost of the materials, not the anticipated cost of those materials.
- The total amount of the Federal financial applied to the project, through awards or subawards, is below \$500,000;

The Buy America preference only applies to articles, materials, and supplies that are consumed in, incorporated into, or affixed to an infrastructure project. As such, it does not apply to tools, equipment, and supplies, such as temporary scaffolding, brought to the construction site and removed at or before the completion of the infrastructure project. Nor does a Buy America preference apply to equipment and furnishings, such as movable chairs, desks, and portable computer equipment, that are used at or within the finished infrastructure project, but are not an integral part of the structure or permanently affixed to the infrastructure project.

C. Proof of Domestic Origin. Furnish certification to the Engineer showing the domestic origin of all products covered by this section before they are incorporated into the Work. The Daily Source Report form itself is not acceptable certification of domestic origin. Non-domestic product(s) incorporated into the Work does not relieve the Contractor of any responsibility to correct the Work up to and including removal and replacement of the non-domestic product(s). Products without a traceable domestic origin will be treated as a non-domestic product.

4. CERTIFICATION AGAINST DEBARMENT AND SUSPENSION

The bidder hereby certifies by signing this proposal that, except as noted below, under penalty of perjury and under other such penalties as the laws of this state and the United States of America provide, that the company or any person associated therewith in the capacity of owner, partner, director, officer, principal investigator, project director, manager, auditor, or any position involving the administration of federal funds is **not** currently under suspension, debarment, voluntary exclusion or determination of ineligibility by any federal

agency; that the company or any person associated therewith in the capacity of owner, partner, director, officer, principal investigator, project director, manager, auditor, or any position involving the administration of federal funds has **not** been suspended, debarred, voluntarily excluded or determined ineligible by any federal agency within the past three (3) years; that the company or any person associated therewith in the capacity of owner, partner, director, manager, auditor, or any position involving the administration of federal funds does **not** have a proposed debarment pending; that the company or any person associated therewith in the capacity of owner, partner, director, officer, principal investigator has **not** been indicted, convicted, or had a civil judgment rendered against the company or themselves by a court of competent jurisdiction in any matter involving fraud or official misconduct within the past three (3) years.

If there are exceptions to any of the above clauses, please include a statement with the bid package detailing these exceptions.

Exceptions will not necessarily result in denial of award but will be considered in determining bidder responsibility. For any exception noted, indicate below to whom it applies, initiating agency and dates of action. Providing false information may result in criminal prosecution or administrative sanctions. Execution of this proposal on the signature portion thereof shall also constitute signature of this certification as permitted by Title 28 United States Code, Section 1746.

5. PREQUALIFICATION

Only prequalified contractors are eligible to submit bids for this project. Prequalification status must be in force **at the time of bid, at the time of award, and through the life of the construction contract.** For work types that ODOT does not prequalify, the LPA must still select a qualified contractor. Subcontractors are not subject to the prequalification requirement. The “prime” contractor must perform no less than 30 percent of the total original contract price.

6. PN 033 - 4/18/2008- AS PER PLAN DESIGNATION

(Not required by FHWA, but strongly suggested if As Per Plan is used by the LPA)

The “As Per Plan” designation is sometimes added to item descriptions in the proposal to assist contractors with easily identifying standard items that have been altered by plan notes.

The “As Per Plan” designation has proven to be a very useful tool for the contractors. However, its use was never intended to relieve the contractors of their responsibility to read, bid, and construct all items in accordance with all governing plan notes. Therefore, the absence of an “As Per Plan” designation on some item descriptions in the proposal for which there are clear and controlling plan notes does not relieve the contractors of the responsibility to read, bid, and construct those particular items in accordance with the governing plan notes.

Be advised that the item descriptions in the bidding proposal must be read or interpreted with the governing plan notes and the Construction and Material Specification Manual. A claim based upon an “order of precedence” basis will be denied. In the event that a conflict, either real or perceived, exists between the item description and the governing plan note, the contractors are to request clarification through the pre-bid process.

7. FEDERALLY REQUIRED EQUAL EMPLOYMENT OPPORTUNITY (EEO) CERTIFICATION FORM

The bidder hereby certifies that he or she **has**, **has not**, participated in a previous contract or subcontract subject to the equal opportunity clause, as required by Executive Orders 10925, 11114, or 11246, and that he or she **has**, **has not**, filed with the Joint Reporting Committee, the Director of the Office of Federal Contract Compliance, a Federal Government Contract Compliance, a Federal Government contracting or administering agency, or the former President's Committee on Equal Employment Opportunity, all reports due under the applicable filing requirements. The bidder must circle the appropriate “has” or “has not” above.

8. PN 017 - 10/15/2004 - FEDERALLY REQUIRED EEO CERTIFICATION CLAUSE

The Federally Required EEO Certification is required by the Equal Employment Opportunity Regulations of the Secretary of Labor (41 CFR 60-1.7 (b) (1)) and must be submitted by bidders and proposed subcontractors only in connection with contracts and subcontracts which are subject to the equal opportunity clause. Contracts and subcontracts which are exempt from the equal opportunity clause are set forth in 41 CFR 60-1.5. (Generally only contracts or subcontracts of \$10,000 or under are exempt.)

Currently, Standard Form 100 (EEO-1) is the only report required by the Executive Orders or their implementing regulations.

Proposed prime contractors and subcontractors who have participated in a previous contract or subcontract subject to the Executive Orders and have not filed the required reports should note that 41 CFR 60-1.7 (b) (1) prevents the award of contracts and subcontracts unless such contractor submits a report covering the delinquent period or such other period specified by the Federal Highway Administration or by the Director, Office of Federal Contract Compliance, U.S. Department of Labor.

9. PN 026 - 10/15/2004 - CERTIFICATION OF NON-SEGREGATED FACILITIES

- A. Certification of Non-segregated Facilities, as required by the May 9, 1967, Order of the Secretary of Labor (32 F.R. 7439, May 19, 1967) on Elimination of Segregated Facilities (for a Federal-aid highway construction contract exceeding \$10,000 which is not exempt from the provisions of the Equal Opportunity clause).
- B. Bidders are cautioned as follows: By signing this bid, the bidder has agreed to the provisions of the "Certification of Non-segregated Facilities" in this proposal. This certification provides that the bidder does not maintain or provide for his or her employees' facilities which are segregated on a basis of race, creed, color, or national origin, whether such facilities are segregated by directive or on a de facto basis. The certification also provides that the bidder will not maintain such segregated facilities.
- C. Bidders receiving Federal-aid highway construction contract awards exceeding \$10,000 which are not exempt from the provisions of the Equal Opportunity clause, will be required to provide for the forwarding of the following notice to prospective subcontractors for construction contracts and material suppliers where the subcontracts or material supply agreements exceed \$10,000 and are not exempt from the provisions of the Equal Opportunity clause.

"Notice to Prospective Subcontractors and Material Suppliers of Requirement for Certification of Non-segregated Facilities" -

- A. A Certification of Non-segregated Facilities as required by the May 9, 1967, Order of the Secretary of Labor (32 F.R. 7439, May 19, 1967) on Elimination of Segregated Facilities, which is included in the proposal, or attached hereto, must be submitted by each subcontractor and material supplier prior to the award of the subcontract or consummation of a material supply agreement if such subcontract or agreement exceeds \$10,000 and is not exempt from the provisions of the Equal Opportunity clause.
- B. Subcontractors and material suppliers are cautioned as follows: By signing the subcontract or entering into a material supply agreement, the subcontractor or material supplier will be deemed to have signed and agreed to the provisions of the "Certification of Non-segregated Facilities" in the subcontract or material supply agreement. This certification provides that the subcontractor or material supplier does not maintain or provide for his or her employees facilities which are segregated on the basis of race, creed, color, or national origin, whether such facilities are segregated by directive or on a de facto basis. The certification also provides that the subcontractor or material supplier will not maintain such segregated facilities.
- C. Subcontractors or material suppliers receiving subcontract awards or material supply agreements exceeding \$10,000 which are not exempt from the provisions of the Equal Opportunity clause will be required to provide for the forwarding of this notice to prospective subcontractors for construction contracts and material suppliers where the subcontracts or material supply agreements exceed \$10,000 and are not exempt from the provisions of the Equal Opportunity clause.

10. PN 003 - 10/15/2004 - TITLE VI RELATED STATUTES NON-DISCRIMINATION STATEMENT

The LPA, under Title VI of the Civil Rights Act and related statutes, ensures that no person within the LPA shall on the grounds of race, color, national origin, sex, disability, or age be excluded from participation in, be denied the benefits of, or be otherwise subjected to discrimination under any program or activity it administers.

11. CERTIFICATION OF COMPLIANCE WITH AFFIRMATIVE ACTION PROGRAMS

In accordance with Ohio Administrative Code §9.47, before any Contract is awarded, the LPA will require the Bidder to furnish a valid Certificate of Compliance with Affirmative Action Programs, issued by the State EEO Coordinator dated prior to the date fixed for the opening of bids.

12. PN 020- 10/21/2022- NOTICE OF REQUIREMENT OF AFFIRMATIVE ACTION TO ENSURE EQUAL EMPLOYMENT OPPORTUNITY AND WORKFORCE DIVERSITY REQUIREMENTS ON ALL FEDERALLY FUNDED PROJECTS (CLOSE MONITORING AND ENFORCEMENT CURRENTLY APPLIES TO PROJECT AMOUNT GREATER THAN \$10M ONLY).¹ PLEASE NOTE THAT ODOT MAY REQUEST INFORMATION AT ANY TIME FOR PROJECTS UNDER \$10M, AS NEEDED.

The bidder’s attention is called to the affirmative action obligations required by the specifications set forth in 23 CFR Part 230, 41 CFR Part 60, Executive Order 11246, Section 503, and the affirmative action provisions of Vietnam Era Veterans' Readjustment Assistance Act (VEVRAA) of 1974.

WORKFORCE UTILITATION GOALS

Utilization goals applicable to the project, expressed in percentages, for minority and female participation for each construction craft can be found on ODOT’s website at [Contracts | Ohio Department of Transportation](http://www.odot.state.oh.us/Contracts/Ohio%20Department%20of%20Transportation/Contracts/Construction/CensusForAllCounties.xlsx). These goals are based on 2020 census data and represent the area, per craft, minority, and female availability pool.

- Census Availability Percentages for minority and female workers** by craft per county (applicable to project):
<http://www.dot.state.oh.us/Divisions/ContractAdmin/Contracts/Construction/CensusForAllCounties.xlsx>
<http://www.dot.state.oh.us/Divisions/ContractAdmin/Contracts/Construction/CensusForAllCounties.pdf>
- Statewide utilization obligations/ goals for minority workers** by county (applicable to each project).
- Statewide utilization obligation/ goal for female workers is 6.9%** and applies the same for each county.

Source: US Department of Labor’s, Office of Federal Contract Compliance Programs, Technical Assistance Guide for Construction Contractors (pp. 126 – 127)
[Construction Contractors Technical Assistance Guide \(dol.gov\)](http://www.dol.gov/eis/whistleblowers/technical-assistance-guide-for-construction-contractors)

Ohio 064 Youngstown-Warren, OH:

SMSA (Standard Metropolitan Statistical Area) Counties:

9320 Youngstown - Warren, OH

OH Mahoning; OH Trumbull.

9.4

¹ All Federally Funded projects greater than \$10K are required to meet the workforce requirements; however close monitoring and enforcement of those over \$10M are defined by ODOT regularly tracking hiring progress with quarterly workforce utilization reports provided to district and contractor staff at progress meetings along with submission of Good Faith Efforts, at the end of a project. GFEs are only requested in the event of a shortfall in female and minority workforce percentages.

Non-SMSA Counties	6.7
OH Columbiana; PA Lawrence; PA Mercer.	
065 Cleveland, OH:	
SMSA Counties:	
0080 Akron, OH	7.8
OH Portage; OH Summit.	
1320 Canton, OH	6.1
OH Carroll; OH Stark.	
1680 Cleveland, OH	16.1
OH Cuyahoga; OH Geauga; OH Lake; OH Medina.	
4440 Lorain-Elyria, OH	9.3
OH Lorain.	
4800 Mansfield, OH	6.3
OH Richland.	
Non-SMSA Counties:	11.3
OH Ashland; OH Ashtabula; OH Coshocton; OH Crawford; OH Erie; OH Holmes; OH Huron; OH Tuscarawas; OH Wayne.	
066 Columbus, OH:	
SMSA Counties:	
1840 Columbus, OH	10.6
OH Delaware; OH Fairfield; Franklin; OH Madison; OH Pickaway.	
Non-SMSA Counties	7.3
OH Athens; OH Fayette; OH Guernsey; OH Hocking; OH Jackson; OH Knox; OH Licking; OH Marion; OH Meigs; OH Morgan; OH Morrow; OH Muskingum; OH Noble; OH Perry; OH Pike; OH Ross; OH Scioto; OH Union; OH Vinton.	
067 Cincinnati, OH:	
SMSA Counties:	
1640 Cincinnati, OH-KY-IN	11.0
IN Dearborn; KY Boone; KY Campbell; KY Kenton; OH Clermont; OH Hamilton; OH Warren.	
3200 Hamilton - Middletown, OH	5.0
OH Butler.	
Non-SMSA Counties	9.2
IN Franklin; IN Ohio; IN Ripley; IN Switzerland; KY Bracken; KY Carroll; KY Fleming; KY Gallatin; KY Grant; KY Lewis; KY Mason; KY Owen; KY Pendleton; KY Robertson; OH Adams; OH Brown; OH Clinton; OH Highland.	
068 Dayton, OH:	
SMSA Counties:	
2000 Dayton, OH	11.5
OH Greene; ON Miami; OH Montgomery; OH Preble.	
7960 Springfield, OH	7.8
OH Champaign; OH Clark.	
Non-SMSA Counties	9.9
OH Darke; OH Logan; ON Shelby.	
069 Lima, OH:	
SMSA Counties:	
4320 Lima, OH	4.4
OH Allen; OH Auglaize; OH Putnam; OH Van Wert.	
Non-SMSA Counties	3.5
OH Hardin; OH Mercer.	
070 Toledo, OH:	
SMSA Counties:	
8400 Toledo, OH-MI	8.8
MI Monroe; OH Fulton; OH Lucas; OH Ottawa; OH Wood.	
Non-SMSA Counties	7.3

MI Lenawee; OH Hancock; OH Henry; OH Sandusky; OH Seneca; OH Wyandot.

The New Hire Definition for the purposes of on-the-job training and workforce utilization is as follows:

An individual who has a break in service (not on an employer's payroll) for a period of twelve (12) months or longer and the person affected is not a salaried employee but belongs to a union craft. Individuals compensated for training or incidental work which does not cause a break in unemployment compensation, i.e., paid by voucher check or petty cash, are considered new hires if the individual's break in service is twelve (12) months or longer.

The time frame for a new hire shall be associated with the first project worked for that contractor regardless of whether it is public or private. When reporting a newly hired employee, the contractor shall identify that employee as a new hire on that specific project only. Subsequent work, barring a break in service of twelve (12) months or more, would not qualify the employee as a new hire for that contractor.

Compliance: The contractor's compliance shall be based on the implementation of affirmative action obligations required by the specifications set forth in 23 CFR Part 230, and its good faith efforts to meet these obligations. The hours of minority and female employment and training must be substantially uniform throughout the length of the contract, and in each trade, and the contractor shall make a good faith effort to employ minorities and females on each of its projects. The transfer of minority or female employees or trainees from contractor to contractor or from project to project for the sole purpose of meeting the affirmative action obligations shall be a violation of the contract and regulations in 23 CFR Part 230. The good faith efforts put forth by the contractor will be measured against the total work hours performed.

Under FHWA, ODOT is the authority tasked with ensuring that the contractor adheres to the aforementioned regulations. In addition to complying with the Required Contract Provisions, the contractor shall provide immediate written notification to ODOT when referral practices of the union(s) with which the contractor has a collective bargaining agreement impede the company's efforts to meet its equal opportunity obligations.

The U.S. Department of Labor, Office of Federal Contract Compliance Programs (OFCCP), administers and enforces equal employment opportunity laws that apply to Federal government contractors and subcontractors supplying goods and services, including construction, to the Federal Government under 41 CFR Part 60, Executive Order 11246, Section 503, and the affirmative action provisions of VEVRAA. The OFCCP monitors compliance with these laws primarily through compliance evaluations, during which a compliance officer examines the contractor's affirmative action efforts and employment practices. Under Executive Order 11246, the OFCCP may perform contract compliance reviews on contractors involved with federally funded ODOT projects.

Requirements for affirmative action obligations governing OFCCP contract compliance reviews are those listed in the Federal Register for the Economic Area.

[Federal Register :: Government Contractors, Affirmative Action Requirements](#) (2000)

[Federal Register :: RIN 1250-AA10](#) (2020 updates)

ADDITIONAL REQUIREMENTS FOR ODOT PROJECTS WITH STATE FUNDING

The Ohio Department of Development (ODOD), Minority Business Division, is responsible for ensuring state contractors implement and adhere to the State of Ohio's affirmative action program pursuant to [Ohio Administrative Code \(OAC\) 123: Chapters 123:2-3-01 through 123:2-3-07](#). Specifically, this unit's responsibilities includes the issuance of certificates of compliance under [ORC 9.47](#) and [153.08](#), conducting project site visits, and compliance reviews (desk audits) to ensure contractors utilize minorities and women in the construction trades, and maintain a working environment free of discrimination, harassment, and intimidation. The ODOD may perform contract compliance reviews on contractors involved with state or state assisted projects. Requirements for affirmative action obligations governing ODOD contract compliance reviews are those listed in OAC 123:2-3-02, for the Metropolitan Statistical Area in which a project is located.

All prime and subcontractors regardless on the number of employees or the state contract amount are required to submit monthly utilization reports (Input Form 29) to the Ohio Department of Development covering the contractor's total workforce within the state of Ohio (private sector and public sector projects). The reports must be filed electronically by the 10th of each month, beginning with the contract award and continuing until the contractor or subcontractor completes performance of the contract, as set forth in OAC 123:2-9-01.

I-29 monthly reports must be submitted via the Ohio Business Gateway portal: <https://ohio.gov/wps/portal/gov/site/business/resources/ohio-business-gateway> / [Ohio Business Gateway | Ohio.gov | Official Website of the State of Ohio](#)

Steps to Submit the I-29 Form:

1. Visit [Ohio Business Gateway](#)
2. Log in using username and password (OH|ID)
3. Ensure "Equal Opportunity Division" is among available service areas
4. Ensure "Input 29" is among available transactions
5. Select "Input 29" and complete the form
6. Click "File" button on the Summary page to see a confirmation page
7. Submit supporting documentation (if required) to: das-eod.bccu@das.ohio.gov

I-29 reports are used by ODOT to create monthly utilization work hour reports to monitor adherence to on-the-job training requirements and workforce diversity requirements. Prime contractors and subcontractors shall provide monthly utilization work hour reports for the contractor's or subcontractor's total workforce within the state of Ohio to the compliance officer of the contracting agency (ODOT). A contractor's or subcontractor's failure to submit a monthly utilization work hour report shall be a basis for invoking any of the sanctions set forth in rule 123:2-7-01 of the Ohio Administrative Code.

13. PN 059 - 10/15/2004 - WAGE DETERMINATION APPEALS PROCESS

- 1.) Has there been an initial decision in the matter? This can be:
 - * An existing published wage determination
 - * A survey underlying a wage determination
 - * A Wage and Hour Division letter setting forth a position on a wage determination matter
 - * A conformance (additional classification and rate) ruling

On survey related matters, initial contact, including requests for summaries of surveys, should be with the Wage and Hour Regional Office for the area in which the survey was conducted because those Regional Offices have responsibility for the Davis-Bacon survey program. If the response for this initial contact is not satisfactory, the process described in 2.) and 3.) should be followed.

Regarding any other matter not yet ready for the formal process described within this section, initial contact should be made with the Branch of Construction Wage Determinations. Write to:

Branch of Construction Wage Determination
Wage and Hour Division
U. S. Department of Labor
200 Constitution Avenue, N.W.
Washington, D. C. 20210

- 2.) If the answer to the question in 1.) is yes, an interested party (those affected by the action) can request review and reconsideration from the Wage and Hour Administrator (see 29 CFR Part 1.8 and 29 CFR Part 7). Write to:

Wage and Hour Administrator
U. S. Department of Labor
200 Constitution Avenue, N.W.
Washington, D. C. 20210

The request should be accompanied by a full statement of the interested party's position and any information (wage payment data, project description, area practice material, etc.) that the requester considers relevant to the issue.

- 3.) If the decision of the Administrator is not favorable, an interested party may appeal directly to the Administrative Review Board (formerly the Wage Appeals Board). Write to:

Administrative Review Board

U. S. Department of Labor
200 Constitution Avenue, N. W.
Washington, D. C. 20210

4.) All decisions by the Administrative Review Board are final.

14. PN 061 –10/22/2012- WAGE SCALE ON ALL FEDERAL-AID PROJECTS

The wage rates for this project were determined by the Secretary of Labor in accordance with Federal-Aid requirements. The LPA must formally incorporate them into the contract documents.

Contractors shall use only the classifications and wage rates set forth in the United States Department of Labor (USDOL) wage decision found at the website noted below on payrolls submitted to the ODOT District Office. Additionally, please note that the wage modification in effect at the time of the project sale date shall be used by all contractors.

This USDOL wage decision may be viewed by accessing the United States Department of Labor (USDOL) website at:

<https://sam.gov/content/wage-determinations>

This contract requires the payment of the total of the basic hourly rates plus the fringe benefits payments for each classification in accordance with the following regulations which by reference are made part of this contract:

- 1) The U.S. Department of Labor Regulations, Title 29, Subtitle A, Part 5, Sections 5.5, 5.31, and 5.32, most recent revision at contract execution.
- 2) Form FHWA-1273 (most recent revision at contract execution) Part IV. Payment of Predetermined Minimum Wage and Part V. Statements and Payrolls. (Form FHWA-1273 shall be physically incorporated in all contracts, subcontracts, and lower-tier subcontracts.)

The failure to pay prevailing wages to all laborers and mechanics employed on this project shall be considered a breach of contract. Such a failure may result in the termination of the contract and debarment.

The contractor and all subcontractors shall pay all wages and fringe benefits by company funds transfer or legal tender. All payroll records and company funds transfer transactions or legal tender transactions shall be maintained for at least three (3) years after final acceptance as defined in Section 109.12 of the ODOT C&MS. The contractor's and all subcontractor's payroll records and canceled pay checks shall be made available for inspection by the Department and the U.S. Department of Labor, upon request, anytime during the life of the contract, and for three (3) years thereafter by the U.S. Department of Labor. Additionally, the contractor and all subcontractors shall permit such representatives to interview any employees during working hours while the employee is on the job.

The wage and fringe rates determined for this project shall be posted by the contractor in a prominent and accessible place on the project, field office, or equipment yard where they can be easily read by the workers.

The contractor and all subcontractors shall submit to the District Construction Office certified payrolls each week beginning three (3) weeks after the start of work. These payrolls shall be on a Form WH-347 or equivalent and shall show the following:

- 1) Employee name, address, classification, and hours worked.
- 2) The basic hourly and overtime rate paid, total pay, and the manner in which fringe benefit payments have been irrevocably made.
- 3) The project number and pay week dates.
- 4) Original signature of a company officer on the certification statement.

Additionally, a copy of the "Apprentice Certification" obtained from the Ohio State Apprenticeship Council must accompany all certified payrolls submitted for all apprentices working on this project.

Please be aware it is ultimately the responsibility of the contractor to ensure all laws relating to prevailing wages in the USDOL Regulations, Title 29, parts 1 and 5, are strictly adhered to by all subcontractors on the project.

If the contractor or any subcontractor fails to comply with any of the provisions contained in this proposal note, the Department may terminate the contract, debar the contractor or subcontractor, and/or withhold or suspend pay estimates after written notice and a reasonable opportunity to comply has been provided.

The applicable wage and fringe rates for this project are to be incorporated in their entirety as an attachment to the executed contract.

15. LIMITATION ON USE OF CONTRACT FUNDS FOR LOBBYING

- A. The prospective bidder certifies, by signing and submitting this bid proposal, to the best of his or her knowledge and belief that:
1. No Federal appropriated funds have been paid or will be paid, by or on behalf of the undersigned, to any person for influencing or attempting to influence an officer or employee of any Federal agency, a member of Congress, an officer or employee of Congress, or an employee of a member of Congress in connection with the awarding of any Federal contract, the making of any Federal grant, the making of any Federal loan, the entering into of any cooperative agreement, and the extension, continuation, renewal, amendment, or modification of any Federal contract, grant, loan, or cooperative agreement.
 2. If any funds other than Federal appropriated funds have been paid or will be paid to any person for influencing or attempting to influence an officer or employee of any Federal agency, a member of Congress, an officer or employee of Congress, or an employee of a member of Congress in connection with this Federal contract, grant, loan, or cooperative agreement, the undersigned shall complete and submit Standard Form-LLL, "Disclosure Form to Report Lobbying" in accordance with its instructions.
- B. This certification is a material representation of fact upon which reliance was placed when this transaction was made or entered into. This certification is a prerequisite for making or entering into this transaction imposed by Section 1352, Title 31, U.S. Code. Any person who fails to file the required certification shall be subject to civil penalty of not less than \$10,000 and not more than \$100,000 for each such failure.
- C. The prospective bidder also agrees by submitting his or her bid proposal that he or she shall require the language of this certification be included in all lower tier subcontracts which exceed \$100,000 and that all such subcontractors shall certify and disclose accordingly.

16. PN 045 - 10/15/2004 - NON -COLLUSION AFFIDAVIT

In accordance with Title 23 USC, Section 112 and ORC, Chapter 1331 et. seq: and Sections 2921.11 and 2921.13, the bidder hereby states, under penalty of perjury and under other such penalties as the law provides, that he/she or his/her agents or employees have not entered, either directly or indirectly, into any agreement, participated in any collusion, or otherwise taken any action in restraint of free competitive bidding in connection with this proposal. Execution of this proposal on the signature portion thereof shall also constitute signature of this Non-Collusion Affidavit as permitted by title 28 USC, Section 1746.

REPORTING BID RIGGING

To report bid rigging activities call:

1-800-424-9071

The U.S. Department of Transportation (USDOT) operates the above toll-free "hotline" Monday through Friday, 8:00 a.m. to 5:00 p.m. eastern time. Anyone with knowledge of possible bid rigging, bidder collusion, or other fraudulent activities should use the "hotline" to report such activities.

The "hotline" is part of the USDOT's continuing effort to identify and investigate highway construction contract fraud and abuse and is operated under the direction of the USDOT Inspector General. All information will be treated confidentially, and caller anonymity will be respected.

17. PN 014 - 10/15/2004 - DRUG-FREE WORKPLACE

The prime contractor agrees to comply with all applicable state and federal laws regarding drug-free workplace. The prime contractor shall make a good faith effort to ensure that all its employees while working on this project will not purchase, transfer, use, or possess illegal drugs or alcohol or abuse prescription drugs in any way.

The prime contractor shall also require this contractual obligation be placed in all subcontractor and materialman contracts it enters into and further requires all subcontractors and materialmen place the same contractual obligations in each of their lower-tier contracts.

18. PN 034 - 05/25/2011 – DRUG FREE SAFETY PROGRAM

During the life of this project, the contractor and all its subcontractors who provide labor on the project site must be enrolled in and remain in good standing in the Ohio Bureau of Worker's Compensation (OBWC) Drug-Free Safety Program (DFSP) or a comparable program approved by the OBWC.

In addition to being enrolled in and in good standing in an OBWC-approved DFSP or a comparable Drug Free Workplace Program (DFWP) approved by the OBWC, the LPA requires each contractor and subcontractor that provides labor to subject its employees who perform labor on the project site to random drug testing of five (5) percent of its employees. The random drug testing percentage must also include the on-site supervisors of the contractors and subcontractors. Upon request, the contractor and subcontractor shall provide evidence of required testing to the LPA.

Each subcontractor shall require all lower-tier subcontractors who provide labor on the project site with whom the subcontractor is in contract for the work to be enrolled in and be in good standing in the OBWC DFSP or an OBWC-approved DFWP prior to a lower-tier subcontractor providing labor at the site.

The LPA will declare a bid non-responsive and ineligible for award if the contractor is not enrolled in and in good standing in the OBWC's DFSP Discount Program or a similar program approved by the OBWC within eight (8) days of the bid opening. Furthermore, the LPA will deny all requests to sublet when the subcontractor does not comply with the provisions of this proposal note.

Failure of the contractor to require a subcontractor to be enrolled in and be in good standing in the OBWC DFSP or an OBWC-approved DFWP prior to the time the subcontractor provides labor at the site shall result in the contractor being found in breach of the contract and that breach shall be used in the responsibility analysis of that contractor or the subcontractor who was not enrolled in a program for future contracts with the State for five (5) years after the date of the breach.

19. OHIO WORKERS' COMPENSATION COVERAGE

The contractor must secure and maintain valid Ohio workers' compensation coverage until the project has been finally accepted by ODOT. A certificate of coverage evidencing valid workers' compensation coverage must be submitted to the LPA before the contract will be executed by the LPA.

The contractor must immediately notify the LPA in writing if it or any subcontractor fails or refuses to renew their workers' compensation coverage. Furthermore, the contractor must notify the LPA in writing if its or any of its subcontractor's workers' compensation policies are canceled, terminated, or lapse.

The failure to maintain valid workers' compensation coverage shall be considered a breach of contract which may result in the contractor or subcontractor being removed from the project, withholding of pay estimates, and/or termination of the contract.

20. PN 038 - 10/15/2004 - UNRESOLVED FINDING FOR RECOVERY

The contractor affirmatively represents to the LPA that it is not subject to a finding for recovery under ORC §9.24, or that it has taken the appropriate remedial steps required under §9.24 or otherwise qualifies under that section. The contractor agrees that if this representation is deemed to be false, the contract shall be void ab initio as between the parties to this contract, and any funds paid by the state hereunder shall be immediately repaid to the LPA, or an action for recovery may be immediately commenced by the LPA and/or for recovery of said funds.

21. PN 039 - 10/15/2004 - ASSIGNMENT OF ANTITRUST CLAIMS IN STATE CONTRACT LANGUAGE

The contractor should recognize that in actual economic practice, overcharges resulting from antitrust violations are usually borne by ODOT and/or the LPA. As consideration for the Award of the Contract and intent to be legally bound, the contractor acting herein by and through the person signing this contract on behalf of the contractor as a duly authorized agent, hereby assigns, sells, conveys, and transfers to ODOT and/or the LPA any and all right, title, and interest to any and all claims and causes of action the contractor now has or hereafter requires under state or federal antitrust laws provided the claims or causes of action related to the goods or services are the subject to the contract. In addition, the contractor warrants and represents that it will require all of its subcontractors and first-tier suppliers to assign all federal and state antitrust claims and causes of action to ODOT and/or the LPA. The provisions of this article shall become effective at the time the LPA executes this contract without further acknowledgment by any of the parties.

All contracting entities shall assign their rights and responsibilities to ODOT and/or the LPA for all antitrust claims and causes of action regarding subcontractors.

22. PN 024 – 04/21/2006 – US ARMY CORPS OF ENGINEERS AND OHIO ENVIRONMENTAL PROTECTION AGENCY PERMITS

The above referenced permits are incorporated and made a part of this contract as special provisions incorporated herein. Therefore, in the event the contractor or its agents refuse or fail to adhere to the requirements of the US Army Corps of Engineers 404 Permit and/or the Ohio Environmental Protection Agency's 401 Water Quality Certification and an assessment or fine is made or levied against ODOT and/or the LPA, the contractor shall reimburse the Department within thirty (30) calendar days of the notice of assessment or fine, or the Department may withhold the amount of the fine from the contractor's next pay estimate. All money collected or withheld from the contractor shall be delivered to the permitting agencies issuing the assessment or fine.

These fines are not to be construed as a penalty but are liquidated damages to recover costs assessed against the Department due to the contractor's refusal or failure to comply with the permits.

23. PN 007 – 1/31/2021- DBE TRUCKING

Title 49 CFR Section 26.55(d)(4)(5)(6) governs trucking operations.

The Disadvantaged Business Enterprise (DBE) trucking firm must be able to quote and negotiate its own prices. The DBE trucking firm must also provide a quote for each project on which the firm is to be utilized toward the project DBE goal.

The DBE will be responsible for the management and supervision of their trucking operation on each contract. A DBE is not performing a Commercially Useful Function (CUF) if the contract exists for the purpose of creating the appearance of DBE participation.

The DBE must own and operate at least one fully licensed, insured, and operational truck used on the contract.

The DBE receives credit for the total value of the transportation services the DBE provides on the contract using trucks the DBE owns, insures, and operates using drivers it employs (not 1099/independent contractors).

The DBE may lease trucks on a long-term basis (a year or more) and receive full DBE credit as long as employees of the DBE operate the truck.

A lease must indicate the DBE has exclusive use of and control over the truck, including responsibility of maintenance and insurance. This does not preclude the leased truck from working for others during the term of the lease with the DBE's consent as long as the lease gives the DBE absolute priority for use of the leased truck. Leased trucks must display the DBE's name and identification number as well.

The DBE must carry a copy of the lease agreement in the leased truck when working onsite.

Truck Monitoring:

Credit for expenditures with DBEs for materials or supplies toward the DBE goal is described as follows:

1. A DBE firm may be a regular dealer in bulk items such as petroleum products, steel, cement, gravel, stone, or asphalt without owning, operating, or maintaining a place of business if the firm both owns and operates distribution equipment for the products. Any supplementation of a regular dealer's own distribution equipment shall be by a long-term lease agreement and not on an ad hoc or contract-by-contract basis.
2. When the materials or supplies are obtained from a DBE Materials and Supplies Vendor (MSV) manufacturer the prime contractor may receive credit for 100 percent of the cost of the materials or supplies toward the DBE goal. For purposes of this section, a manufacturer is a firm that operates or maintains a factory or establishment that produces on the premises the materials, supplies, articles, or equipment required under the contract and of the general character described by the specifications.
3. When the materials or supplies are purchased from a DBE MSV regular dealer or supplier, the prime contractor may receive credit for up to 60 percent of the cost of the materials or supplies toward the DBE goal. For purposes of this section, a regular dealer or supplier is a firm that owns, operates, or maintains a store, warehouse, or other establishment in which the materials, supplies, articles or equipment of the general character described by the specifications and required under the contract are bought, kept in stock, and regularly sold or leased to the public in the usual course of business.

Historically, 60% of the cost of materials and supplies purchased from a DBE MSV (100% from a DBE MSV manufacturer) would normally be counted toward DBE goals. Effective September 1, 2018:

- Prime contractors must obtain information about the method of procurement for each item to be procured from a DBE MSV. The DBE Affirmation Form has been modified to accommodate this information.
- To be eligible to receive 100% credit toward DBE goals for a materials and supplies subcontract:
 - The DBE MSV must be certified with the correct (manufacturer) NAICS code for the item
 - The DBE MSV must be certified with the correct descriptor for the item
 - The role the DBE MSV will play on the specific procurement in question must be consistent with the manufacture of the item, as indicated by the information provided by the DBE MSV
- To be eligible to receive 60% credit toward DBE goals for a materials and supplies subcontract:
 - The DBE MSV must be certified with the correct (wholesale or retail) NAICS code for the item
 - The DBE MSV must be certified with the correct descriptor for the item
 - The role the DBE MSV will play on the specific procurement in question must be consistent with the regular sale or lease of the item, as indicated by the information provided by the DBE MSV
 - The item must not be drop-shipped

- The above scenario applies to both bulk items (petroleum products, steel, cement, gravel, stone, asphalt, and others that ODOT may consider to be bulk items) and non-bulk items. For bulk items, there is an additional scenario whereby a contract with a DBE MSV could receive 60% credit. To be eligible to receive 60% credit toward DBE goals for a bulk item materials and supplies subcontract:
 - The DBE MSV must be certified with the correct (wholesale or retail and trucking) NAICS codes for the item
 - The DBE MSV must be certified with the correct descriptor for the item
 - The role the DBE MSV will play on the specific procurement in question must be consistent with the regular sale or lease of the item, as indicated by the information provided by the DBE MSV
 - The DBE MSV must deliver the bulk item from a non-DBE vendor to the prime contractor using distribution equipment that it both owns [or for which it has a long-term (1 year or more) lease] and operates with its regular (not ad hoc) employees
- If not eligible for 100% or 60% credit, an item may still be eligible for credit toward DBE goals, but only for the fee or commission the DBE MSV receives for its services, and only if the following additional criteria are met:
 - The DBE MSV must be certified with NAICS code 425120 Wholesale Trade Agents and Brokers
 - The DBE MSV must convincingly explain how the prime contractor benefits by transacting business with it rather than directly with the non-DBE vendor from which the DBE MSV is re-selling
- The usual good faith efforts process applies.
- All credit toward DBE goals is conditional. Actual credit will be determined based upon invoices, receipts, and/or transportation documents/bills of lading, which must be submitted to ODOT as they are received throughout the course of the project.

DBE TRUCKING DISCLOSURE AFFIDAVIT

In order to ensure the prime contractors are monitoring DBE trucking/hauling operations on projects with federal funding, prime contractors must complete the DBE Trucking Disclosure Affidavits Section (“Affidavit”) when completing and submitting the Prompt Payment Spreadsheet for reimbursement. The Affidavit will be completed by the prime contractor on the Prompt Payment Spreadsheet and, once submitted, will be routed to the project’s SharePoint site. This information will be used to affirm DBE and non-DBE trucking utilized by each DBE firm performing those duties during the previous month. The LPA and ODOT will monitor trucking with the following requirements for all Local-let projects:

- Prime contractors will be required to provide a master list of all anticipated DBE trucking firms to the District Construction Monitor (DCM) at the time of the Pre-Construction Meeting.
 - If no DBE trucking is anticipated on a project, the prime contractor will check the box “No Anticipated DBE Trucking Affidavit” on the first submittal of the Prompt Payment Spreadsheet. If DBE trucking/hauling does occur, the prime contractor must notify the LPA within seven (7) days of the DBE trucking activity. The prime contractor will then complete the Affidavits as required below on each Prompt Payment Spreadsheet.
- Prime contractors will be required to complete the Affidavit disclosing the DBE trucking operations during the previous month when completing the new Prompt Payment Spreadsheet. The prime contractor will complete the Trucking Affidavit section on the Prompt Payment Spreadsheet on each reimbursement submittal. The prime contractor will select one of the following options on the Trucking Affidavit section of the form.
 - The DBE firm performed trucking by utilizing their own equipment and workforce and/or work was subcontracted to another DBE (i.e., only trucking that can be counted for DBE participation was utilized).
 - No other information is required. The prime contractor will sign and submit the Affidavit.

- The DBE firm utilized DBE & Non-DBE trucking.
 - If selected, the prime contractor will provide a list of non-DBE trucking that was utilized (i.e., not all trucking will earn DBE credit).
- No trucking was performed.
 - No other information is required. The prime contractor will sign and submit the Affidavit.
- The DCM will perform a check of the Affidavit when reviewing the Prompt Payment Spreadsheet when submitted for reimbursement. The LPA and/or Compliance Managers will follow up on any red flags. For example, if the LPA compares information collected during the CUF process with the affidavit and sees any discrepancies. ([Prompt Payment, DBE Tracking and CUF | Ohio Department of Transportation](#))
- Trucking will continue to be monitored at project sites by construction field staff and the LPAs.

SANCTIONS AND ADMINISTRATIVE REMEDIES

Failure by the prime contractor to follow the DBE Trucking Disclosure Affidavit requirements may result in the issuance of sanctions as follows:

- 1st Level Occurrence: The Department will issue a Letter of Reprimand to the contractor (applies if there is a failure to submit the Affidavits and/or the Affidavits are not submitted timely; if the prime contractor completes the No Anticipated DBE Trucking Affidavit, utilizes DBE trucking, and does not notify the LPA within seven (7) days of the activity).
- 2nd Level Occurrence: The Department may withhold an estimate in the amount due to the DBE trucking firm the Affidavit was not submitted for (applies if there is a failure to submit the Affidavits and/or the Affidavits are not submitted timely; if the prime contractor completes the No Anticipated DBE Trucking Affidavit, utilizes DBE trucking and does not notify the LPA within seven (7) days of the activity).
- 3rd Level Occurrence: If a pattern of not submitting the Affidavit(s) persists or the contractor has falsified, misrepresented, or withheld information; ODOT can pursue other remedies available by law including suspension, revocation, and/or debarment.

Factors to be considered in issuing sanctions may include, but are not limited to the following:

- The contractor's past project practices,
- The magnitude and the type of offense,
- The degree of the contractor's culpability,
- Any steps taken to rectify,
- The contractor's record of performance on other projects, and
- The number of times the contractor has been previously sanctioned by ODOT.

DBE MSV DIRECTORY - <http://www.dot.state.oh.us/Divisions/ODI/SDBE/Pages/DBE-Directory.aspx> (select MSV only)

DBE AFFIRMATION FORM - The new DBE Affirmation Form is now available at [DBE Affirmation Form - Projects Sold on or after 9/1/18 | Ohio Department of Transportation](#).

Opening Prompt Payment (PP) Spreadsheet (Trucking Affidavit Section on PP Spreadsheet) through GoFormz:

1. Obtain a MyODOT account
 - a. Click [Link](#)
 - b. Click "Launch MyODOT"
 - c. Click: "Click Here"
 - d. Complete Account Application under "Request an Account"

2. Getting GoFormz Access

- a. Email GoFormz.Help@dot.ohio.gov put Create GoFormz Account in the subject line
- b. Login for GoFormz will be emailed back
- c. Click www.goformz.com

Additional guidance can be found by [Clicking Here](#)

24. PN 013 – 10/20/23 DISADVANTAGED BUSINESS ENTERPRISE (DBE) UTILIZATION PLAN AND GOOD FAITH EFFORTS – LPA Projects

DEFINITION OF *DAYS*

Unless otherwise noted, *days* means calendar days, but in computing any period of time described in this proposal note, the day from which the period begins to run is not counted, and when the last day of the period is a Saturday, Sunday, or Federal or State holiday, the period extends to the next day that is not a Saturday, Sunday, or Federal or State holiday. See <https://www.opm.gov/policy-data-oversight/pay-leave/federal-holidays> for a list of Federal holidays. State holidays are those designated in division (A) of section 124.19 of the Revised Code (<https://codes.ohio.gov/ohio-revised-code/section-124.19>), with modifications as designated in the first two sentences of division (B)(4) of section 124.18 of the Revised Code (<https://codes.ohio.gov/ohio-revised-code/section-124.18>). (State holidays are generally the same as Federal holidays.)

DBE UTILIZATION PLAN

The bidder's DBE Utilization Plan **must be submitted by the bidder prior to bid opening at https://odot.formstack.com/forms/dbe_copy**. By submitting a DBE Utilization Plan, the Bidder affirms it will be using the DBE firms identified in the Utilization Plan to meet the DBE contract goal. The Bidder further affirms it will not deviate from the Utilization Plan without ODOT's prior written consent.

Unless the bidder is a certified DBE firm, **a bid opened without a DBE Utilization Plan submitted prior to bid opening will be deemed unresponsive.**

The DBE Utilization Plan shall include the following information:

1. The names of the certified DBE firms(s) that will be used to meet the DBE goal
2. A description of the work each DBE will perform. To count toward meeting a goal, each DBE firm must be certified in a NAICS code applicable to the kind of work the firm would perform on the contract
3. Whether the DBE firms(s) being used to meet the goal will be utilized as a subcontractor, regular dealer, manufacturer, consultant, or other capacity
4. The dollar amount of the participation of each DBE firm used to meet the DBE goal.

PROJECTS AWARDED ON ALTERNATES

In the event the project is awarded on alternates, which increases or decreases the total dollar amount of the bid, a revision to the DBE Utilization Plan and DBE Affirmation Form(s) shall be submitted and approved by the Office of Business & Economic Opportunity within five (5) days after the notification of the alternates.

DBE AFFIRMATION

The Apparent Low Bidder (ALB) shall ensure the DBE firms being utilized to meet the DBE goal affirm their participation in the bid within five (5) days after the bid opening to ODOT. The contract dollar amount(s) and/or DBE firm(s) included in the ALB's DBE Utilization Plan must match the contract dollar amount(s) and/or DBE firm(s) included on the DBE Affirmation Form(s). If the contract dollar amount(s) and/or DBE firm(s) do not match, the ALB shall utilize the Request for Consent to Terminate/Reduce a DBE Commitment form located at [DBE Commitment Reduction or Termination Form | Ohio Department of Transportation](#) and submit for review and approval by the Office of Business & Economic Opportunity within five (5) days of the bid opening.

The ALB shall utilize the DBE Affirmation Form located at [DBE Affirmation Form - Projects Sold on or after 9/1/18 | Ohio Department of Transportation](#). The DBE Affirmation Form will be utilized as written confirmation from each listed DBE firm that it is participating in the contract in the type and amount of work provided in the bidder's DBE Utilization Plan. The ALB shall submit a separate DBE Affirmation Form for each DBE it is utilizing for the DBE goal as well as their Good Faith Efforts package if they were not able to attain the DBE Goal via DBE participation.

All other bidders shall submit a DBE Affirmation Form(s) if notified the information is required in order for ODOT to complete its assessment. Bidders shall have five (5) days from the date of notification to submit all required DBE Affirmation Forms to ODOT. Notification will be by email.

In the event a DBE firm fails to confirm the information contained in the DBE Affirmation Form within five (5) days of bid opening, the ALB shall submit a Request for Consent to Terminate/Reduce a DBE Commitment form, as set forth herein. The Request for Consent to Terminate/Reduce a DBE Commitment form shall be submitted within five (5) days after bid opening in order for the ALB to still be considered for contract award. The ALB shall include as its reason for termination the DBE firm's failure to provide a timely affirmation and should include all efforts the ALB made to obtain the affirmation from the DBE firm and shall attach proof of these efforts, if available. If the ALB intends to replace the DBE Firm, it shall include the replacement firm's information on the form. In the event the ALB is unable to affirm a DBE firm included in its original DBE Utilization Plan at bid submission and it results in a goal shortfall, Good Faith Efforts (GFE's) must be submitted by the fifth day after bid opening. All GFE documentation submitted for consideration should demonstrate the efforts the bidder made prior to the time of bid submission to secure sufficient DBE participation on the project to meet the DBE goal although the bidder was unable to do so. A DBE firm's failure to timely confirm information contained in the DBE Affirmation Form will be considered as good cause to terminate the DBE firm and will also be considered a part of the ALB's Good Faith Efforts in meeting the goal.

DBE BIDDERS

In the event the Bidder is a certified DBE firm, the Bidder is not required to complete a DBE Utilization Plan as set forth above and would not need to submit a DBE Affirmation Form for the work it is planning to self-perform in order to meet the goal.

JOINT VENTURES

If the bidder is a Joint Venture, the Joint Venture will only be considered a Certified DBE firm if the Joint Venture itself has been certified. The Joint Venture may, however, utilize a Certified DBE firm that is also a partner in the Joint Venture as part of its DBE Utilization Plan. The Certified DBE Firm/Joint Venture Partner, however, does not need to submit a DBE Affirmation Form for any work the Certified DBE Firm/Joint Venture Partner is going to perform to meet the goal. ODOT will consider submission of the Joint Venture's bid as the Certified DBE Firm/Joint Venture Partner's confirmation that it is participating in the contract.

GOOD FAITH EFFORTS (GFE's)

If the DBE contract goal established by ODOT is not met, the ALB shall demonstrate it made adequate good faith efforts to meet the goal, even though it did not succeed in obtaining enough DBE participation to do so.

If the ALB does not meet the goal at bid time, the ALB shall submit its Good Faith Efforts (GFE's) documentation within five (5) days of the bid opening. Submission of DBE affirmation(s) with additional participation sufficient to meet the DBE contract goal does not cure the ALB's failure to meet the goal at bid time or eliminate the ALB's responsibility of submitting GFE's within five (5) days of the bid opening.

The ALB shall demonstrate its GFE's by submitting the following information within five (5) days after the bid opening:

1. All written quotes received from certified DBE firms
2. All written (including email) communications between the ALB and DBE firms
3. All written solicitations to DBE firms, even if unsuccessful
4. Copies of each non-DBE quote when a non-DBE was selected over a DBE for work on the contract
5. Phone logs of communications with DBE firms

The ALB shall utilize the Pre-Bid GFE Template to document their GFE's. This template and supporting documentation shall be sent along with any DBE Affirmation Forms within five (5) days of bid opening. ODOT has provided Good Faith Efforts Guidance located at [Good Faith Efforts \(GFE\) for Contractors | Ohio Department of Transportation](#)

All other bidders shall submit documentation of GFE's if notified the information is required in order for ODOT to complete its bid assessment. Bidders shall have five (5) days from the date of notification to submit all required GFE documentation. Notification will be by email.

ODOT shall utilize the guidance set forth in 49 CFR §26.53 Appendix A in determining whether the bidder has made adequate good faith efforts to meet the goal.

ADMINISTRATIVE RECONSIDERATION

ODOT will review the GFE documentation and issue a written determination on whether adequate GFE's have been demonstrated prior to contract award. If ODOT determines the ALB has failed to demonstrate adequate GFE's to meet the goal, the ALB will have an opportunity for administrative reconsideration prior to the contract being awarded.

As part of this reconsideration, the ALB may provide written documentation or argument concerning the issue of whether it met the goal or made adequate good faith efforts to do so. Such written documentation or argument must be provided to ODOT, attention to the Office of Chief Legal Counsel, 1980 West Broad Street, MS 1500, Columbus, Ohio 43223 (with copy to the Office of Contract Sales, MS 4110), within two (2) business days of ODOT's written determination that GFE's were not adequately demonstrated. The ALB may also include in their written documentation a request for an in-person meeting to discuss the issue of whether it met the goal or made adequate good faith efforts to do so. ODOT's Office of Chief Legal Counsel will respond to the ALB within five (5) business days of receiving written documentation or holding the in-person meeting.

ODOT will send the ALB a written decision on reconsideration explaining the basis for finding that the ALB did or did not meet the goal or make adequate good faith efforts to do so. The result of the reconsideration process is not administratively appealable to the United States Department of Transportation.

TERMINATION OR REPLACEMENT OF A DBE

By submitting a DBE Utilization Plan, the bidder is committing to use the DBE firms identified in the plan. The ALB/Awarded Contractor shall utilize the specific DBEs listed in the DBE Utilization Plan to perform the work and supply the materials for which each is listed unless the ALB/Awarded Contractor obtains written consent as provided in this paragraph. In order to request termination or substitution of a DBE firm, the ALB/Awarded Contractor shall utilize the Request for Consent to Terminate/Reduce a DBE Commitment form located at [DBE Commitment Reduction or Termination Form | Ohio Department of Transportation](#).

This termination/replacement procedure applies only to DBE firms or the amount of work being utilized to meet the goal.

Without ODOT's written consent to terminate/replace a DBE firm being utilized to meet the goal, the Awarded Contractor shall not be entitled to any payment for DBE listed work or material unless it is performed or supplied by the listed DBE.

GOOD CAUSE

ODOT may provide written consent to terminate a DBE only if it agrees, for reasons stated in a concurrence document, the ALB/Awarded Contractor has good cause to terminate the DBE firm.

For purposes of this section, good cause to terminate a DBE includes the following circumstances:

- 1) The listed DBE firm fails or refuses to provide the required DBE Affirmation Form or to execute a written contract
- 2) The listed DBE firm fails or refuses to perform the work of its subcontract in a manner consistent with normal industry standards. Provided, however, that good cause does not exist if the failure or

- refusal of the DBE firm to perform its work on the subcontract results from the bad faith or discriminatory action of the awarded contractor
- 3) The listed DBE firm fails or refuses to meet the awarded contractor's reasonable, nondiscriminatory bond requirements.
 - 4) The listed DBE firm becomes bankrupt, insolvent, or exhibits credit unworthiness
 - 5) The listed DBE firm is ineligible to work on public works projects because of suspension and debarment proceedings pursuant 2 CFR Parts 180, 215 and 1200 or applicable state law
 - 6) ODOT has determined the listed DBE firm is not a responsible contractor
 - 7) The listed DBE firm voluntarily withdraws from the project and provides to the contractor written notice of its withdrawal
 - 8) The listed DBE is ineligible to receive DBE credit for the type of work required
 - 9) A DBE owner dies or becomes disabled with the result that the listed DBE contractor is unable to complete its work on the contract; and
 - 10) Other documented good cause that ODOT determines compels the termination of the DBE firm. Provided that good cause does not exist if the awarded contractor seeks to terminate a DBE it relied upon to obtain the contract so the awarded contractor can self-perform the work for which the DBE contractor was engaged or so the awarded contractor can substitute another DBE or non-DBE contractor after contract award.

REPLACEMENT

When a DBE firm is terminated or fails to complete its work on the contract for any reason, the Awarded Contractor must make GFEs to find another DBE firm to replace the original DBE. These GFEs shall be directed at finding another DBE to perform at least the same amount of work under the contract as the DBE that was terminated, to the extent needed to meet the contract goal. The GFEs shall be documented by the Awarded Contractor. If ODOT requests documentation under this provision, the Awarded Contractor shall submit the documentation within seven (7) days, which may be extended for an additional seven (7) days if necessary, at the request of the contractor, and ODOT shall provide a written determination to the contractor stating whether GFEs have been demonstrated.

In addition to post-award terminations, the provisions of this section apply to pre-award deletions and substitutions of DBE firms put forward by bidders in the DBE Utilization Plan.

ADDITION

In the event additional DBE participation is required for the project, the Awarded Contractor shall utilize the DBE Affirmation Form located at [DBE Affirmation Form - Projects Sold on or after 9/1/18 | Ohio Department of Transportation](#). The DBE Affirmation Form will be utilized as written confirmation from each DBE firm that it is participating in the contract in the kind and amount of work on the project.

WRITTEN NOTICE TO DBE

Before transmitting to ODOT its request to terminate and/or substitute a DBE firm, the ALB/Awarded Contractor must give notice in writing to the DBE firm with a copy to ODOT of its intent to request to terminate and/or substitute and the reason(s) for the request.

The ALB/Awarded Contractor must give the DBE five (5) days to respond to the notice, advising ODOT and the ALB/Awarded Contractor of the reasons, if any, why it objects to the proposed termination of its subcontract and why ODOT should not approve the ALB/Awarded Contractor's action. If required in a particular case as a matter of public necessity (e.g., safety), ODOT may provide a response period shorter than five (5) days.

GOAL ATTAINMENT POST AWARD

The Awarded Contractor shall make available upon request a copy of all DBE subcontracts. The Awarded Contractor shall ensure that all subcontracts or agreements with DBEs require that the subcontract and all lower-tier subcontracts be performed in accordance with this Proposal Note.

Approval of a DBE Utilization Plan does not ensure approval of C-92 Requests to Sublet, nor does approval of a DBE Utilization Plan indicate the DBE goal has been met. ODOT will monitor goal attainment throughout the life of the project. It is the responsibility of the Awarded Contractor to advise ODOT of any changes to the DBE Utilization plan throughout the life of the project. The DBE goal of a project is stated as a percentage of the contract. In the event the contract amount increases or decreases, the actual dollar amount of the DBE goal for the project may increase or decrease accordingly.

SANCTIONS AND ADMINISTRATIVE REMEDIES

PRE-BID

Failure by the ALB to do any of the following shall result in the bid being rejected as non-responsive in accordance with ORC §5525.08:

1. Failure to submit a complete DBE Utilization Plan at the time of bid
2. Failure to submit DBE Affirmation Form(s) and/or failure to submit Request for Consent to Terminate/Reduce a DBE Commitment form(s) as required by this Proposal Note; or
3. Failure to meet the goal and/or failure to demonstrate GFEs to meet the goal as required by this Proposal Note.

POST-BID

Failure by the Awarded Contractor to carry out the requirements of this Proposal Note, including the submission of adequate good faith efforts to meet the goal for a project, is a material breach of the contract and may result in the issuance of sanctions as follows:

- 1st Tier: Letter of Reprimand
- 2nd Tier: Damages equivalent to the DBE shortfall
- 3rd Tier: If a pattern of paying damages persists or the contractor has falsified, misrepresented, or withheld information, ODOT can pursue other remedies available by law including suspension, revocation, and/or debarment.

Factors to be considered in issuing sanctions may include, but are not limited to, the following:

- the magnitude and the type of offense
- the degree of the contractor's culpability
- any steps taken to rectify
- the contractor's record of performance on other projects including, but not limited to:
 - annual DBE participation
 - annual DBE participation on projects without goals
 - the number of complaints ODOT has received regarding the contractor
 - the number of times the contractor has been previously sanctioned by ODOT

25. PN 031 - 6/27/2023 – PROMPT PAYMENT - LOCAL-LET CONSTRUCTION PROJECTS

The U.S. Department of Transportation's (USDOT's) rules related to Disadvantaged Business Enterprises are published in 49 CFR Part 26. Within 49 CFR Part 26, 49 CFR 26.29 lays out the prompt payment requirements that apply to ODOT (the Department), its subrecipients (LPA's), and, by extension, both prime contractors and subcontractors (including non-DBEs). The 49 CFR 26.29 requirements apply only to federally funded contracts (i.e., contracts with DOT financial assistance). The prime contractor must comply with this Proposal Note and the Department's prompt payment requirements as published in 107.21 of the C&MS.

Second-tier subcontract means a subcontract awarded directly by the subcontractor for the purpose of acquiring supplies or services (including construction) for performance of a prime contract. It does not include the contractor's supplier agreements with vendors, such as long-term arrangements for materials or supplies that benefit multiple contracts and/or the costs of which are normally applied to a contractor's general and administrative expenses or indirect costs.

The Department will monitor payments made by prime contractors and subcontractors for compliance with this Proposal Note, C&MS 107.21 and, where applicable, 49 CFR 26.29. To facilitate this monitoring, the

Department requires both prime **and** subcontractors to report their payments to all subcontractors/second-tier subcontractors with the submission of each invoice. The payment data reported must include any retainage withheld (*when allowable under the Department's [Retainage Policy dated 4/14/21](#)*) and any previously withheld retainage released. All such reporting must take place through a web-based submission on GoFormz. Please note: submission through GoFormz is required for all Local-let projects. Invoices will not be approved and processed for payment unless this reporting form has been submitted and received by the Department.

The prime/subcontractor must report the following information:

- The name of the payee
- The dollar amount of the payment to the payee
- The date the payee was paid
- The amount of retainage withheld (if any)

Ohio's 10-day prompt payment requirement is based on the payer's payment issuance date and NOT the payee's payment receipt date.

The prime/subcontractor must sign each reported payment and submit to ODOT via the GoFormz website.

The second-tier subcontractor is responsible for completing the affirmation of payment form in GoFormz.

The prime is responsible for ensuring that all subcontractors and second-tier subcontractors are correctly completing all prompt payment forms via the GoFormz website.

If the prime or subcontractor(s) fail to submit the aforementioned documentation with each invoice, they will be determined to be non-compliant and invoices will not be processed for payment.

Payees must verify each payment reported by the payer within thirty (30) days of the payment being signed by the payer. This verification must include:

- Whether the payment was received, and if so, whether it was or was not as expected
- The dollar amount of the payment received
- The date the payment was received

The prime contractor shall fully complete the last prompt payment form upon receipt of final payment.

SANCTIONS AND ADMINISTRATIVE REMEDIES

Failure by the prime contractor and/or subcontractor(s) to follow Prompt Payment requirements may result in the issuance of sanctions as follows:

- 1st Tier: Notice of Violation followed by a Letter of Reprimand
- 2nd Tier: If corrective actions are not taken within the specified three (3) business days, a pay estimate in the amount due to the subcontractor(s) that was not reported or paid may be withheld.
- 3rd Tier: If a pattern of paying damages persists or the contractor has falsified, misrepresented, or withheld information, ODOT can pursue other remedies available by law including suspension, revocation, and/or debarment.

Factors to be considered in issuing sanctions may include, but are not limited to the following:

- the magnitude and the type of offense
- the degree of the contractor's culpability
- any steps taken to rectify
- the contractor's record of performance on other projects
- the number of times the contractor has been previously sanctioned by ODOT

26. WAIVER OF C&MS 614.03

ODOT's 2023 C&MS section 614.03, third paragraph, does not apply to any project which is not physically located on the National Highway System (NHS), and/or does not impact NHS traffic in any way.

27. ODOT AS OBLIGEE ON BOND

The contractor shall furnish a performance and payment bond in an amount at least equal to 100 percent of the estimate as security for the faithful performance of its contract. In addition to the project owner, ODOT shall be named as an obligee.

28. NON-DISCRIMINATION PROVISIONS

A. Compliance with Regulations: The contractor will comply with the regulations relative to nondiscrimination in Federally-assisted programs of the USDOT Title 49 CFR, Part 21, as they may be amended from time to time, (hereinafter referred to as the "Regulations"), which are herein incorporated by reference and made a part of this contract.

In addition, the contractor will comply with the provisions of the Americans with Disabilities Act, Section 504 of the Rehabilitation Act, FHWA Guidance, and any other Federal, State, and/or local laws, rules and/or regulations (hereinafter referred to as "ADA/504").

B. Nondiscrimination: The contractor, with regard to the work performed by it during the contract, will not discriminate on the grounds of race, color, national origin, sex, age, or disability, in the selection and retention of subcontractors, including procurements of materials and leases of equipment. The contractor will not participate, either directly or indirectly, in the discrimination prohibited by section 21.5 of the Regulations, including employment practices when the contract covers a program set forth in Appendix B of the Regulations, as well as the ADA/504 regulations.

C. Solicitations for Contractors or Subcontractors, including Procurement of Materials and Equipment: In all solicitations either by competitive bidding or negotiation made by the contractor for work to be performed under a contract or subcontract including procurements of materials or leases of equipment, each potential subcontractor or supplier will be notified by the contractor of the contractor's obligations under this contract and the Regulations relative to nondiscrimination on the grounds of race, color, national origin, sex, age, or disability.

D. Information and Reports: The contractor will provide all information and reports required by the Regulations or directives issued pursuant thereto, and will permit access to its books, records, accounts, other sources of information, and its facilities as may be determined by the State or FHWA to be pertinent to ascertain compliance with such Regulations, orders, and instructions. Where any information required of the contractor is in the exclusive possession of another who fails or refuses to furnish this information, the contractor will so certify to the State or FHWA, as appropriate, and will set forth what efforts it has made to obtain the information.

E. Sanctions for Noncompliance: In the event of the contractor's noncompliance with the nondiscrimination provisions of this contract, the LPA will impose such contract sanctions as it or State/FHWA may determine to be appropriate, including, but not limited to:

- (1) Withholding of payments to the contractor under the contract until the contractor complies, and/or
- (2) Cancellation, termination, or suspension of the contract, in whole or in part.

F. Incorporation of Provisions: The contractor will include the provisions of paragraphs (A) through (E) above in every contract or subcontract, including procurements of materials and leases of equipment, unless exempt by the Regulations, or directives issued pursuant thereto. The contractor will take such action with respect to any subcontractor procurement as the LPA or State/FHWA may direct as a means of enforcing such provisions including sanctions for noncompliance; provided, however, in the event the contractor becomes involved in, or is threatened with, litigation with a subcontractor or supplier as a result of such direction, the contractor may request the LPA/State to enter into such litigation to protect the interests of the LPA and the

State. In addition, the LPA/State may request the United States to enter into such litigation to protect the interests of the United States.

29. PN 015 - 04/17/2020 - CONTRACT PROVISIONS FOR FEDERAL-AID CONSTRUCTION CONTRACTS

The required contract provisions for federal-aid construction contracts are hereby incorporated by reference as if rewritten herein. The current version of Form FHWA-1273 (available at <https://www.fhwa.dot.gov/programadmin/contracts/1273/1273.pdf>) shall be physically incorporated in all contracts, subcontracts, and lower-tier subcontracts (excluding purchase orders, rental agreements and other agreement for supplies or services related to a construction contract). The prime contractor shall be responsible for ensuring that the FHWA-1273 is physically incorporated into all lower-tier subcontracts.

SANCTIONS AND ADMINISTRATIVE REMEDIES

Failure by the prime contractor to include the provisions of FHWA-1273 in their contract or in their lower-tier subcontracts may result in the issuance of sanctions as follows:

1st Tier: Letter of Reprimand

2nd Tier: Damages equivalent to the daily liquidated damages amount found in section 108.07 for each incident of non-compliance

3rd Tier: If a pattern of paying damages persists or the contractor has falsified, misrepresented, or withheld information, the LPA can pursue other remedies available by law including suspension, revocation, and/or debarment.

Factors to be considered in issuing sanctions may include, but are not limited to the following:

- the magnitude and the type of offense
- the degree of the contractor's culpability
- any steps taken to rectify
- the contractor's record of performance on other projects; and
- the number of times the contractor has been previously sanctioned by the LPA.

30. PN 032 – 01/31/2021 – C92s REQUIRED ON LOCAL-LET CONSTRUCTION PROJECTS

State and Federal law requires that all contractors and subcontractors participating on state or federally funded projects be evidenced in writing and in conformity with all applicable state and federal laws and regulations.

Effective immediately, all projects advertising after 2/1/2021 will require that a Request to Sublet (C92) form is completed for each subcontractor and DBE materials supplier working on the project prior to the start of work.

A template for this form may be found and submit via the GoFormz website located at www.goformz.com.

31. REQUIRED CONTRACT PROVISIONS FOR FEDERAL-AID CONSTRUCTION CONTRACTS (Electronic Form FHWA 1273 – October 23, 2023) (SEE NEXT PAGE)

**REQUIRED CONTRACT PROVISIONS
FEDERAL-AID CONSTRUCTION CONTRACTS**

- I. General
- II. Nondiscrimination
- III. Non-segregated Facilities
- IV. Davis-Bacon and Related Act Provisions
- V. Contract Work Hours and Safety Standards Act Provisions
- VI. Subletting or Assigning the Contract
- VII. Safety: Accident Prevention
- VIII. False Statements Concerning Highway Projects
- IX. Implementation of Clean Air Act and Federal Water Pollution Control Act
- X. Certification Regarding Debarment, Suspension, Ineligibility and Voluntary Exclusion
- XI. Certification Regarding Use of Contract Funds for Lobbying
- XII. Use of United States-Flag Vessels:

ATTACHMENTS

A. Employment and Materials Preference for Appalachian Development Highway System or Appalachian Local Access Road Contracts (included in Appalachian contracts only)

I. GENERAL

1. Form FHWA-1273 must be physically incorporated in each construction contract funded under title 23, United States Code, as required in 23 CFR 633.102(b) (excluding emergency contracts solely intended for debris removal). The contractor (or subcontractor) must insert this form in each subcontract and further require its inclusion in all lower tier subcontracts (excluding purchase orders, rental agreements and other agreements for supplies or services). 23 CFR 633.102(e).

The applicable requirements of Form FHWA-1273 are incorporated by reference for work done under any purchase order, rental agreement or agreement for other services. The prime contractor shall be responsible for compliance by any subcontractor, lower-tier subcontractor or service provider. 23 CFR 633.102(e).

Form FHWA-1273 must be included in all Federal-aid design-build contracts, in all subcontracts and in lower tier subcontracts (excluding subcontracts for design services, purchase orders, rental agreements and other agreements for supplies or services) in accordance with 23 CFR 633.102. The design-builder shall be responsible for compliance by any subcontractor, lower-tier subcontractor or service provider.

Contracting agencies may reference Form FHWA-1273 in solicitation-for-bids or request-for-proposals documents, however, the Form FHWA-1273 must be physically incorporated (not referenced) in all contracts, subcontracts and lower-tier subcontracts (excluding purchase orders, rental agreements and other agreements for supplies or services related to a construction contract). 23 CFR 633.102(b).

2. Subject to the applicability criteria noted in the following sections, these contract provisions shall apply to all work

performed on the contract by the contractor's own organization and with the assistance of workers under the contractor's immediate superintendence and to all work performed on the contract by piecework, station work, or by subcontract. 23 CFR 633.102(d).

3. A breach of any of the stipulations contained in these Required Contract Provisions may be sufficient grounds for withholding of progress payments, withholding of final payment, termination of the contract, suspension / debarment or any other action determined to be appropriate by the contracting agency and FHWA.

4. Selection of Labor: During the performance of this contract, the contractor shall not use convict labor for any purpose within the limits of a construction project on a Federal-aid highway unless it is labor performed by convicts who are on parole, supervised release, or probation. 23 U.S.C. 114(b). The term Federal-aid highway does not include roadways functionally classified as local roads or rural minor collectors. 23 U.S.C. 101(a).

II. NONDISCRIMINATION (23 CFR 230.107(a); 23 CFR Part 230, Subpart A, Appendix A; EO 11246)

The provisions of this section related to 23 CFR Part 230, Subpart A, Appendix A are applicable to all Federal-aid construction contracts and to all related construction subcontracts of \$10,000 or more. The provisions of 23 CFR Part 230 are not applicable to material supply, engineering, or architectural service contracts.

In addition, the contractor and all subcontractors must comply with the following policies: Executive Order 11246, 41 CFR Part 60, 29 CFR Parts 1625-1627, 23 U.S.C. 140, Section 504 of the Rehabilitation Act of 1973, as amended (29 U.S.C. 794), Title VI of the Civil Rights Act of 1964, as amended (42 U.S.C. 2000d et seq.), and related regulations including 49 CFR Parts 21, 26, and 27; and 23 CFR Parts 200, 230, and 633.

The contractor and all subcontractors must comply with: the requirements of the Equal Opportunity Clause in 41 CFR 60-1.4(b) and, for all construction contracts exceeding \$10,000, the Standard Federal Equal Employment Opportunity Construction Contract Specifications in 41 CFR 60-4.3.

Note: The U.S. Department of Labor has exclusive authority to determine compliance with Executive Order 11246 and the policies of the Secretary of Labor including 41 CFR Part 60, and 29 CFR Parts 1625-1627. The contracting agency and the FHWA have the authority and the responsibility to ensure compliance with 23 U.S.C. 140, Section 504 of the Rehabilitation Act of 1973, as amended (29 U.S.C. 794), and Title VI of the Civil Rights Act of 1964, as amended (42 U.S.C. 2000d et seq.), and related regulations including 49 CFR Parts 21, 26, and 27; and 23 CFR Parts 200, 230, and 633.

The following provision is adopted from 23 CFR Part 230, Subpart A, Appendix A, with appropriate revisions to conform to the U.S. Department of Labor (US DOL) and FHWA requirements.

1. Equal Employment Opportunity: Equal Employment Opportunity (EEO) requirements not to discriminate and to take affirmative action to assure equal opportunity as set forth under laws, executive orders, rules, regulations (see 28 CFR Part 35, 29 CFR Part 1630, 29 CFR Parts 1625-1627, 41 CFR Part 60 and 49 CFR Part 27) and orders of the Secretary of Labor as modified by the provisions prescribed herein, and imposed pursuant to 23 U.S.C. 140, shall constitute the EEO and specific affirmative action standards for the contractor's project activities under this contract. The provisions of the Americans with Disabilities Act of 1990 (42 U.S.C. 12101 et seq.) set forth under 28 CFR Part 35 and 29 CFR Part 1630 are incorporated by reference in this contract. In the execution of this contract, the contractor agrees to comply with the following minimum specific requirement activities of EEO:

a. The contractor will work with the contracting agency and the Federal Government to ensure that it has made every good faith effort to provide equal opportunity with respect to all of its terms and conditions of employment and in their review of activities under the contract. 23 CFR 230.409 (g)(4) & (5).

b. The contractor will accept as its operating policy the following statement:

"It is the policy of this Company to assure that applicants are employed, and that employees are treated during employment, without regard to their race, religion, sex, sexual orientation, gender identity, color, national origin, age or disability. Such action shall include: employment, upgrading, demotion, or transfer; recruitment or recruitment advertising; layoff or termination; rates of pay or other forms of compensation; and selection for training, including apprenticeship, pre-apprenticeship, and/or on-the-job training."

2. EEO Officer: The contractor will designate and make known to the contracting officers an EEO Officer who will have the responsibility for and must be capable of effectively administering and promoting an active EEO program and who must be assigned adequate authority and responsibility to do so.

3. Dissemination of Policy: All members of the contractor's staff who are authorized to hire, supervise, promote, and discharge employees, or who recommend such action or are substantially involved in such action, will be made fully cognizant of and will implement the contractor's EEO policy and contractual responsibilities to provide EEO in each grade and classification of employment. To ensure that the above agreement will be met, the following actions will be taken as a minimum:

a. Periodic meetings of supervisory and personnel office employees will be conducted before the start of work and then not less often than once every six months, at which time the contractor's EEO policy and its implementation will be reviewed and explained. The meetings will be conducted by the EEO Officer or other knowledgeable company official.

b. All new supervisory or personnel office employees will be given a thorough indoctrination by the EEO Officer, covering all major aspects of the contractor's EEO obligations within thirty days following their reporting for duty with the contractor.

c. All personnel who are engaged in direct recruitment for the project will be instructed by the EEO Officer in the contractor's procedures for locating and hiring minorities and women.

d. Notices and posters setting forth the contractor's EEO policy will be placed in areas readily accessible to employees, applicants for employment and potential employees.

e. The contractor's EEO policy and the procedures to implement such policy will be brought to the attention of employees by means of meetings, employee handbooks, or other appropriate means.

4. Recruitment: When advertising for employees, the contractor will include in all advertisements for employees the notation: "An Equal Opportunity Employer." All such advertisements will be placed in publications having a large circulation among minorities and women in the area from which the project work force would normally be derived.

a. The contractor will, unless precluded by a valid bargaining agreement, conduct systematic and direct recruitment through public and private employee referral sources likely to yield qualified minorities and women. To meet this requirement, the contractor will identify sources of potential minority group employees and establish with such identified sources procedures whereby minority and women applicants may be referred to the contractor for employment consideration.

b. In the event the contractor has a valid bargaining agreement providing for exclusive hiring hall referrals, the contractor is expected to observe the provisions of that agreement to the extent that the system meets the contractor's compliance with EEO contract provisions. Where implementation of such an agreement has the effect of discriminating against minorities or women, or obligates the contractor to do the same, such implementation violates Federal nondiscrimination provisions.

c. The contractor will encourage its present employees to refer minorities and women as applicants for employment. Information and procedures with regard to referring such applicants will be discussed with employees.

5. Personnel Actions: Wages, working conditions, and employee benefits shall be established and administered, and personnel actions of every type, including hiring, upgrading, promotion, transfer, demotion, layoff, and termination, shall be taken without regard to race, color, religion, sex, sexual orientation, gender identity, national origin, age or disability. The following procedures shall be followed:

a. The contractor will conduct periodic inspections of project sites to ensure that working conditions and employee facilities do not indicate discriminatory treatment of project site personnel.

b. The contractor will periodically evaluate the spread of wages paid within each classification to determine any evidence of discriminatory wage practices.

c. The contractor will periodically review selected personnel actions in depth to determine whether there is evidence of discrimination. Where evidence is found, the contractor will promptly take corrective action. If the review indicates that the discrimination may extend beyond the actions reviewed, such corrective action shall include all affected persons.

d. The contractor will promptly investigate all complaints of alleged discrimination made to the contractor in connection with its obligations under this contract, will attempt to resolve such complaints, and will take appropriate corrective action

within a reasonable time. If the investigation indicates that the discrimination may affect persons other than the complainant, such corrective action shall include such other persons. Upon completion of each investigation, the contractor will inform every complainant of all of their avenues of appeal.

6. Training and Promotion:

a. The contractor will assist in locating, qualifying, and increasing the skills of minorities and women who are applicants for employment or current employees. Such efforts should be aimed at developing full journey level status employees in the type of trade or job classification involved.

b. Consistent with the contractor's work force requirements and as permissible under Federal and State regulations, the contractor shall make full use of training programs (i.e., apprenticeship and on-the-job training programs for the geographical area of contract performance). In the event a special provision for training is provided under this contract, this subparagraph will be superseded as indicated in the special provision. The contracting agency may reserve training positions for persons who receive welfare assistance in accordance with 23 U.S.C. 140(a).

c. The contractor will advise employees and applicants for employment of available training programs and entrance requirements for each.

d. The contractor will periodically review the training and promotion potential of employees who are minorities and women and will encourage eligible employees to apply for such training and promotion.

7. Unions: If the contractor relies in whole or in part upon unions as a source of employees, the contractor will use good faith efforts to obtain the cooperation of such unions to increase opportunities for minorities and women. 23 CFR 230.409. Actions by the contractor, either directly or through a contractor's association acting as agent, will include the procedures set forth below:

a. The contractor will use good faith efforts to develop, in cooperation with the unions, joint training programs aimed toward qualifying more minorities and women for membership in the unions and increasing the skills of minorities and women so that they may qualify for higher paying employment.

b. The contractor will use good faith efforts to incorporate an EEO clause into each union agreement to the end that such union will be contractually bound to refer applicants without regard to their race, color, religion, sex, sexual orientation, gender identity, national origin, age, or disability.

c. The contractor is to obtain information as to the referral practices and policies of the labor union except that to the extent such information is within the exclusive possession of the labor union and such labor union refuses to furnish such information to the contractor, the contractor shall so certify to the contracting agency and shall set forth what efforts have been made to obtain such information.

d. In the event the union is unable to provide the contractor with a reasonable flow of referrals within the time limit set forth in the collective bargaining agreement, the contractor will, through independent recruitment efforts, fill the employment vacancies without regard to race, color, religion, sex, sexual orientation, gender identity, national origin, age, or disability; making full efforts to obtain qualified and/or qualifiable minorities and women. The failure of a union to provide

sufficient referrals (even though it is obligated to provide exclusive referrals under the terms of a collective bargaining agreement) does not relieve the contractor from the requirements of this paragraph. In the event the union referral practice prevents the contractor from meeting the obligations pursuant to Executive Order 11246, as amended, and these special provisions, such contractor shall immediately notify the contracting agency.

8. Reasonable Accommodation for Applicants / Employees with Disabilities: The contractor must be familiar with the requirements for and comply with the Americans with Disabilities Act and all rules and regulations established thereunder. Employers must provide reasonable accommodation in all employment activities unless to do so would cause an undue hardship.

9. Selection of Subcontractors, Procurement of Materials and Leasing of Equipment: The contractor shall not discriminate on the grounds of race, color, religion, sex, sexual orientation, gender identity, national origin, age, or disability in the selection and retention of subcontractors, including procurement of materials and leases of equipment. The contractor shall take all necessary and reasonable steps to ensure nondiscrimination in the administration of this contract.

a. The contractor shall notify all potential subcontractors, suppliers, and lessors of their EEO obligations under this contract.

b. The contractor will use good faith efforts to ensure subcontractor compliance with their EEO obligations.

10. Assurances Required:

a. The requirements of 49 CFR Part 26 and the State DOT's FHWA-approved Disadvantaged Business Enterprise (DBE) program are incorporated by reference.

b. The contractor, subrecipient or subcontractor shall not discriminate on the basis of race, color, national origin, or sex in the performance of this contract. The contractor shall carry out applicable requirements of 49 CFR part 26 in the award and administration of DOT-assisted contracts. Failure by the contractor to carry out these requirements is a material breach of this contract, which may result in the termination of this contract or such other remedy as the recipient deems appropriate, which may include, but is not limited to:

- (1) Withholding monthly progress payments;
- (2) Assessing sanctions;
- (3) Liquidated damages; and/or
- (4) Disqualifying the contractor from future bidding as non-responsible.

c. The Title VI and nondiscrimination provisions of U.S. DOT Order 1050.2A at Appendixes A and E are incorporated by reference. 49 CFR Part 21.

11. Records and Reports: The contractor shall keep such records as necessary to document compliance with the EEO requirements. Such records shall be retained for a period of three years following the date of the final payment to the contractor for all contract work and shall be available at reasonable times and places for inspection by authorized representatives of the contracting agency and the FHWA.

a. The records kept by the contractor shall document the following:

(1) The number and work hours of minority and non-minority group members and women employed in each work classification on the project;

(2) The progress and efforts being made in cooperation with unions, when applicable, to increase employment opportunities for minorities and women; and

(3) The progress and efforts being made in locating, hiring, training, qualifying, and upgrading minorities and women.

b. The contractors and subcontractors will submit an annual report to the contracting agency each July for the duration of the project indicating the number of minority, women, and non-minority group employees currently engaged in each work classification required by the contract work. This information is to be reported on [Form FHWA-1391](#). The staffing data should represent the project work force on board in all or any part of the last payroll period preceding the end of July. If on-the-job training is being required by special provision, the contractor will be required to collect and report training data. The employment data should reflect the work force on board during all or any part of the last payroll period preceding the end of July.

III. NONSEGREGATED FACILITIES

This provision is applicable to all Federal-aid construction contracts and to all related construction subcontracts of more than \$10,000. 41 CFR 60-1.5.

As prescribed by 41 CFR 60-1.8, the contractor must ensure that facilities provided for employees are provided in such a manner that segregation on the basis of race, color, religion, sex, sexual orientation, gender identity, or national origin cannot result. The contractor may neither require such segregated use by written or oral policies nor tolerate such use by employee custom. The contractor's obligation extends further to ensure that its employees are not assigned to perform their services at any location under the contractor's control where the facilities are segregated. The term "facilities" includes waiting rooms, work areas, restaurants and other eating areas, time clocks, restrooms, washrooms, locker rooms and other storage or dressing areas, parking lots, drinking fountains, recreation or entertainment areas, transportation, and housing provided for employees. The contractor shall provide separate or single-user restrooms and necessary dressing or sleeping areas to assure privacy between sexes.

IV. DAVIS-BACON AND RELATED ACT PROVISIONS

This section is applicable to all Federal-aid construction projects exceeding \$2,000 and to all related subcontracts and lower-tier subcontracts (regardless of subcontract size), in accordance with 29 CFR 5.5. The requirements apply to all projects located within the right-of-way of a roadway that is functionally classified as Federal-aid highway. 23 U.S.C. 113. This excludes roadways functionally classified as local roads or rural minor collectors, which are exempt. 23 U.S.C. 101. Where applicable law requires that projects be treated as a project on a Federal-aid highway, the provisions of this subpart will apply regardless of the location of the project. Examples include: Surface Transportation Block Grant Program projects funded under 23 U.S.C. 133 [excluding recreational trails projects], the Nationally Significant Freight and Highway

Projects funded under 23 U.S.C. 117, and National Highway Freight Program projects funded under 23 U.S.C. 167.

The following provisions are from the U.S. Department of Labor regulations in 29 CFR 5.5 "Contract provisions and related matters" with minor revisions to conform to the FHWA-1273 format and FHWA program requirements.

1. Minimum wages (29 CFR 5.5)

a. *Wage rates and fringe benefits.* All laborers and mechanics employed or working upon the site of the work (or otherwise working in construction or development of the project under a development statute), will be paid unconditionally and not less often than once a week, and without subsequent deduction or rebate on any account (except such payroll deductions as are permitted by regulations issued by the Secretary of Labor under the Copeland Act ([29 CFR part 3](#))), the full amount of basic hourly wages and bona fide fringe benefits (or cash equivalents thereof) due at time of payment computed at rates not less than those contained in the wage determination of the Secretary of Labor which is attached hereto and made a part hereof, regardless of any contractual relationship which may be alleged to exist between the contractor and such laborers and mechanics. As provided in paragraphs (d) and (e) of 29 CFR 5.5, the appropriate wage determinations are effective by operation of law even if they have not been attached to the contract. Contributions made or costs reasonably anticipated for bona fide fringe benefits under the Davis-Bacon Act ([40 U.S.C. 3141\(2\)\(B\)](#)) on behalf of laborers or mechanics are considered wages paid to such laborers or mechanics, subject to the provisions of paragraph 1.e. of this section; also, regular contributions made or costs incurred for more than a weekly period (but not less often than quarterly) under plans, funds, or programs which cover the particular weekly period, are deemed to be constructively made or incurred during such weekly period. Such laborers and mechanics must be paid the appropriate wage rate and fringe benefits on the wage determination for the classification(s) of work actually performed, without regard to skill, except as provided in paragraph 4. of this section. Laborers or mechanics performing work in more than one classification may be compensated at the rate specified for each classification for the time actually worked therein: *Provided*, That the employer's payroll records accurately set forth the time spent in each classification in which work is performed. The wage determination (including any additional classifications and wage rates conformed under paragraph 1.c. of this section) and the Davis-Bacon poster (WH-1321) must be posted at all times by the contractor and its subcontractors at the site of the work in a prominent and accessible place where it can be easily seen by the workers.

b. *Frequently recurring classifications.* (1) In addition to wage and fringe benefit rates that have been determined to be prevailing under the procedures set forth in [29 CFR part 1](#), a wage determination may contain, pursuant to § 1.3(f), wage and fringe benefit rates for classifications of laborers and mechanics for which conformance requests are regularly submitted pursuant to paragraph 1.c. of this section, provided that:

(i) The work performed by the classification is not performed by a classification in the wage determination for which a prevailing wage rate has been determined;

(ii) The classification is used in the area by the construction industry; and

(iii) The wage rate for the classification bears a reasonable relationship to the prevailing wage rates contained in the wage determination.

(2) The Administrator will establish wage rates for such classifications in accordance with paragraph 1.c.(1)(iii) of this section. Work performed in such a classification must be paid at no less than the wage and fringe benefit rate listed on the wage determination for such classification.

c. *Conformance.* (1) The contracting officer must require that any class of laborers or mechanics, including helpers, which is not listed in the wage determination and which is to be employed under the contract be classified in conformance with the wage determination. Conformance of an additional classification and wage rate and fringe benefits is appropriate only when the following criteria have been met:

(i) The work to be performed by the classification requested is not performed by a classification in the wage determination; and

(ii) The classification is used in the area by the construction industry; and

(iii) The proposed wage rate, including any bona fide fringe benefits, bears a reasonable relationship to the wage rates contained in the wage determination.

(2) The conformance process may not be used to split, subdivide, or otherwise avoid application of classifications listed in the wage determination.

(3) If the contractor and the laborers and mechanics to be employed in the classification (if known), or their representatives, and the contracting officer agree on the classification and wage rate (including the amount designated for fringe benefits where appropriate), a report of the action taken will be sent by the contracting officer by email to DBAconformance@dol.gov. The Administrator, or an authorized representative, will approve, modify, or disapprove every additional classification action within 30 days of receipt and so advise the contracting officer or will notify the contracting officer within the 30-day period that additional time is necessary.

(4) In the event the contractor, the laborers or mechanics to be employed in the classification or their representatives, and the contracting officer do not agree on the proposed classification and wage rate (including the amount designated for fringe benefits, where appropriate), the contracting officer will, by email to DBAconformance@dol.gov, refer the questions, including the views of all interested parties and the recommendation of the contracting officer, to the Administrator for determination. The Administrator, or an authorized representative, will issue a determination within 30 days of receipt and so advise the contracting officer or will notify the contracting officer within the 30-day period that additional time is necessary.

(5) The contracting officer must promptly notify the contractor of the action taken by the Wage and Hour Division

under paragraphs 1.c.(3) and (4) of this section. The contractor must furnish a written copy of such determination to each affected worker or it must be posted as a part of the wage determination. The wage rate (including fringe benefits where appropriate) determined pursuant to paragraph 1.c.(3) or (4) of this section must be paid to all workers performing work in the classification under this contract from the first day on which work is performed in the classification.

d. *Fringe benefits not expressed as an hourly rate.* Whenever the minimum wage rate prescribed in the contract for a class of laborers or mechanics includes a fringe benefit which is not expressed as an hourly rate, the contractor may either pay the benefit as stated in the wage determination or may pay another bona fide fringe benefit or an hourly cash equivalent thereof.

e. *Unfunded plans.* If the contractor does not make payments to a trustee or other third person, the contractor may consider as part of the wages of any laborer or mechanic the amount of any costs reasonably anticipated in providing bona fide fringe benefits under a plan or program, *Provided*, That the Secretary of Labor has found, upon the written request of the contractor, in accordance with the criteria set forth in § 5.28, that the applicable standards of the Davis-Bacon Act have been met. The Secretary of Labor may require the contractor to set aside in a separate account assets for the meeting of obligations under the plan or program.

f. *Interest.* In the event of a failure to pay all or part of the wages required by the contract, the contractor will be required to pay interest on any underpayment of wages.

2. Withholding (29 CFR 5.5)

a. *Withholding requirements.* The contracting agency may, upon its own action, or must, upon written request of an authorized representative of the Department of Labor, withhold or cause to be withheld from the contractor so much of the accrued payments or advances as may be considered necessary to satisfy the liabilities of the prime contractor or any subcontractor for the full amount of wages and monetary relief, including interest, required by the clauses set forth in this section for violations of this contract, or to satisfy any such liabilities required by any other Federal contract, or federally assisted contract subject to Davis-Bacon labor standards, that is held by the same prime contractor (as defined in § 5.2). The necessary funds may be withheld from the contractor under this contract, any other Federal contract with the same prime contractor, or any other federally assisted contract that is subject to Davis-Bacon labor standards requirements and is held by the same prime contractor, regardless of whether the other contract was awarded or assisted by the same agency, and such funds may be used to satisfy the contractor liability for which the funds were withheld. In the event of a contractor's failure to pay any laborer or mechanic, including any apprentice or helper working on the site of the work all or part of the wages required by the contract, or upon the contractor's failure to submit the required records as discussed in paragraph 3.d. of this section, the contracting agency may on its own initiative and after written notice to the contractor, take such action as may be necessary to cause the suspension of any further payment, advance, or guarantee of funds until such violations have ceased.

b. *Priority to withheld funds.* The Department has priority to funds withheld or to be withheld in accordance with paragraph

2.a. of this section or Section V, paragraph 3.a., or both, over claims to those funds by:

- (1) A contractor's surety(ies), including without limitation performance bond sureties and payment bond sureties;
- (2) A contracting agency for its procurement costs;
- (3) A trustee(s) (either a court-appointed trustee or a U.S. trustee, or both) in bankruptcy of a contractor, or a contractor's bankruptcy estate;
- (4) A contractor's assignee(s);
- (5) A contractor's successor(s); or
- (6) A claim asserted under the Prompt Payment Act, [31 U.S.C. 3901–3907](#).

3. Records and certified payrolls (29 CFR 5.5)

a. *Basic record requirements (1) Length of record retention.* All regular payrolls and other basic records must be maintained by the contractor and any subcontractor during the course of the work and preserved for all laborers and mechanics working at the site of the work (or otherwise working in construction or development of the project under a development statute) for a period of at least 3 years after all the work on the prime contract is completed.

(2) *Information required.* Such records must contain the name; Social Security number; last known address, telephone number, and email address of each such worker; each worker's correct classification(s) of work actually performed; hourly rates of wages paid (including rates of contributions or costs anticipated for bona fide fringe benefits or cash equivalents thereof of the types described in [40 U.S.C. 3141\(2\)\(B\)](#) of the Davis-Bacon Act); daily and weekly number of hours actually worked in total and on each covered contract; deductions made; and actual wages paid.

(3) *Additional records relating to fringe benefits.* Whenever the Secretary of Labor has found under paragraph 1.e. of this section that the wages of any laborer or mechanic include the amount of any costs reasonably anticipated in providing benefits under a plan or program described in [40 U.S.C. 3141\(2\)\(B\)](#) of the Davis-Bacon Act, the contractor must maintain records which show that the commitment to provide such benefits is enforceable, that the plan or program is financially responsible, and that the plan or program has been communicated in writing to the laborers or mechanics affected, and records which show the costs anticipated or the actual cost incurred in providing such benefits.

(4) *Additional records relating to apprenticeship.* Contractors with apprentices working under approved programs must maintain written evidence of the registration of apprenticeship programs, the registration of the apprentices, and the ratios and wage rates prescribed in the applicable programs.

b. *Certified payroll requirements (1) Frequency and method of submission.* The contractor or subcontractor must submit weekly, for each week in which any DBA- or Related Acts-covered work is performed, certified payrolls to the contracting

agency. The prime contractor is responsible for the submission of all certified payrolls by all subcontractors. A contracting agency or prime contractor may permit or require contractors to submit certified payrolls through an electronic system, as long as the electronic system requires a legally valid electronic signature; the system allows the contractor, the contracting agency, and the Department of Labor to access the certified payrolls upon request for at least 3 years after the work on the prime contract has been completed; and the contracting agency or prime contractor permits other methods of submission in situations where the contractor is unable or limited in its ability to use or access the electronic system.

(2) *Information required.* The certified payrolls submitted must set out accurately and completely all of the information required to be maintained under paragraph 3.a.(2) of this section, except that full Social Security numbers and last known addresses, telephone numbers, and email addresses must not be included on weekly transmittals. Instead, the certified payrolls need only include an individually identifying number for each worker (e.g., the last four digits of the worker's Social Security number). The required weekly certified payroll information may be submitted using Optional Form WH-347 or in any other format desired. Optional Form WH-347 is available for this purpose from the Wage and Hour Division website at <https://www.dol.gov/sites/dolgov/files/WHD/legacy/files/wh347.pdf> or its successor website. It is not a violation of this section for a prime contractor to require a subcontractor to provide full Social Security numbers and last known addresses, telephone numbers, and email addresses to the prime contractor for its own records, without weekly submission by the subcontractor to the contracting agency.

(3) *Statement of Compliance.* Each certified payroll submitted must be accompanied by a "Statement of Compliance," signed by the contractor or subcontractor, or the contractor's or subcontractor's agent who pays or supervises the payment of the persons working on the contract, and must certify the following:

(i) That the certified payroll for the payroll period contains the information required to be provided under paragraph 3.b. of this section, the appropriate information and basic records are being maintained under paragraph 3.a. of this section, and such information and records are correct and complete;

(ii) That each laborer or mechanic (including each helper and apprentice) working on the contract during the payroll period has been paid the full weekly wages earned, without rebate, either directly or indirectly, and that no deductions have been made either directly or indirectly from the full wages earned, other than permissible deductions as set forth in [29 CFR part 3](#); and

(iii) That each laborer or mechanic has been paid not less than the applicable wage rates and fringe benefits or cash equivalents for the classification(s) of work actually performed, as specified in the applicable wage determination incorporated into the contract.

(4) *Use of Optional Form WH-347.* The weekly submission of a properly executed certification set forth on the reverse side of Optional Form WH-347 will satisfy the requirement for submission of the "Statement of Compliance" required by paragraph 3.b.(3) of this section.

(5) *Signature.* The signature by the contractor, subcontractor, or the contractor's or subcontractor's agent must be an original handwritten signature or a legally valid electronic signature.

(6) *Falsification.* The falsification of any of the above certifications may subject the contractor or subcontractor to civil or criminal prosecution under [18 U.S.C. 1001](#) and [31 U.S.C. 3729](#).

(7) *Length of certified payroll retention.* The contractor or subcontractor must preserve all certified payrolls during the course of the work and for a period of 3 years after all the work on the prime contract is completed.

c. *Contracts, subcontracts, and related documents.* The contractor or subcontractor must maintain this contract or subcontract and related documents including, without limitation, bids, proposals, amendments, modifications, and extensions. The contractor or subcontractor must preserve these contracts, subcontracts, and related documents during the course of the work and for a period of 3 years after all the work on the prime contract is completed.

d. *Required disclosures and access (1) Required record disclosures and access to workers.* The contractor or subcontractor must make the records required under paragraphs 3.a. through 3.c. of this section, and any other documents that the contracting agency, the State DOT, the FHWA, or the Department of Labor deems necessary to determine compliance with the labor standards provisions of any of the applicable statutes referenced by § 5.1, available for inspection, copying, or transcription by authorized representatives of the contracting agency, the State DOT, the FHWA, or the Department of Labor, and must permit such representatives to interview workers during working hours on the job.

(2) *Sanctions for non-compliance with records and worker access requirements.* If the contractor or subcontractor fails to submit the required records or to make them available, or refuses to permit worker interviews during working hours on the job, the Federal agency may, after written notice to the contractor, sponsor, applicant, owner, or other entity, as the case may be, that maintains such records or that employs such workers, take such action as may be necessary to cause the suspension of any further payment, advance, or guarantee of funds. Furthermore, failure to submit the required records upon request or to make such records available, or to permit worker interviews during working hours on the job, may be grounds for debarment action pursuant to § 5.12. In addition, any contractor or other person that fails to submit the required records or make those records available to WHD within the time WHD requests that the records be produced will be precluded from introducing as evidence in an administrative proceeding under [29 CFR part 6](#) any of the required records that were not provided or made available to WHD. WHD will take into consideration a reasonable request from the contractor or person for an extension of the time for submission of records. WHD will determine the reasonableness of the request and may consider, among other things, the location of the records and the volume of production.

(3) *Required information disclosures.* Contractors and subcontractors must maintain the full Social Security number and last known address, telephone number, and email address

of each covered worker, and must provide them upon request to the contracting agency, the State DOT, the FHWA, the contractor, or the Wage and Hour Division of the Department of Labor for purposes of an investigation or other compliance action.

4. Apprentices and equal employment opportunity (29 CFR 5.5)

a. *Apprentices (1) Rate of pay.* Apprentices will be permitted to work at less than the predetermined rate for the work they perform when they are employed pursuant to and individually registered in a bona fide apprenticeship program registered with the U.S. Department of Labor, Employment and Training Administration, Office of Apprenticeship (OA), or with a State Apprenticeship Agency recognized by the OA. A person who is not individually registered in the program, but who has been certified by the OA or a State Apprenticeship Agency (where appropriate) to be eligible for probationary employment as an apprentice, will be permitted to work at less than the predetermined rate for the work they perform in the first 90 days of probationary employment as an apprentice in such a program. In the event the OA or a State Apprenticeship Agency recognized by the OA withdraws approval of an apprenticeship program, the contractor will no longer be permitted to use apprentices at less than the applicable predetermined rate for the work performed until an acceptable program is approved.

(2) *Fringe benefits.* Apprentices must be paid fringe benefits in accordance with the provisions of the apprenticeship program. If the apprenticeship program does not specify fringe benefits, apprentices must be paid the full amount of fringe benefits listed on the wage determination for the applicable classification. If the Administrator determines that a different practice prevails for the applicable apprentice classification, fringe benefits must be paid in accordance with that determination.

(3) *Apprenticeship ratio.* The allowable ratio of apprentices to journeyworkers on the job site in any craft classification must not be greater than the ratio permitted to the contractor as to the entire work force under the registered program or the ratio applicable to the locality of the project pursuant to paragraph 4.a.(4) of this section. Any worker listed on a payroll at an apprentice wage rate, who is not registered or otherwise employed as stated in paragraph 4.a.(1) of this section, must be paid not less than the applicable wage rate on the wage determination for the classification of work actually performed. In addition, any apprentice performing work on the job site in excess of the ratio permitted under this section must be paid not less than the applicable wage rate on the wage determination for the work actually performed.

(4) *Reciprocity of ratios and wage rates.* Where a contractor is performing construction on a project in a locality other than the locality in which its program is registered, the ratios and wage rates (expressed in percentages of the journeyworker's hourly rate) applicable within the locality in which the construction is being performed must be observed. If there is no applicable ratio or wage rate for the locality of the project, the ratio and wage rate specified in the contractor's registered program must be observed.

b. *Equal employment opportunity.* The use of apprentices and journeyworkers under this part must be in conformity with

the equal employment opportunity requirements of Executive Order 11246, as amended, and [29 CFR part 30](#).

c. Apprentices and Trainees (programs of the U.S. DOT).

Apprentices and trainees working under apprenticeship and skill training programs which have been certified by the Secretary of Transportation as promoting EEO in connection with Federal-aid highway construction programs are not subject to the requirements of paragraph 4 of this Section IV. 23 CFR 230.111(e)(2). The straight time hourly wage rates for apprentices and trainees under such programs will be established by the particular programs. The ratio of apprentices and trainees to journeyworkers shall not be greater than permitted by the terms of the particular program.

5. Compliance with Copeland Act requirements. The contractor shall comply with the requirements of 29 CFR part 3, which are incorporated by reference in this contract as provided in 29 CFR 5.5.

6. Subcontracts. The contractor or subcontractor must insert FHWA-1273 in any subcontracts, along with the applicable wage determination(s) and such other clauses or contract modifications as the contracting agency may by appropriate instructions require, and a clause requiring the subcontractors to include these clauses and wage determination(s) in any lower tier subcontracts. The prime contractor is responsible for the compliance by any subcontractor or lower tier subcontractor with all the contract clauses in this section. In the event of any violations of these clauses, the prime contractor and any subcontractor(s) responsible will be liable for any unpaid wages and monetary relief, including interest from the date of the underpayment or loss, due to any workers of lower-tier subcontractors, and may be subject to debarment, as appropriate. 29 CFR 5.5.

7. Contract termination: debarment. A breach of the contract clauses in 29 CFR 5.5 may be grounds for termination of the contract, and for debarment as a contractor and a subcontractor as provided in 29 CFR 5.12.

8. Compliance with Davis-Bacon and Related Act requirements. All rulings and interpretations of the Davis-Bacon and Related Acts contained in 29 CFR parts 1, 3, and 5 are herein incorporated by reference in this contract as provided in 29 CFR 5.5.

9. Disputes concerning labor standards. As provided in 29 CFR 5.5, disputes arising out of the labor standards provisions of this contract shall not be subject to the general disputes clause of this contract. Such disputes shall be resolved in accordance with the procedures of the Department of Labor set forth in 29 CFR parts 5, 6, and 7. Disputes within the meaning of this clause include disputes between the contractor (or any of its subcontractors) and the contracting agency, the U.S. Department of Labor, or the employees or their representatives.

10. Certification of eligibility. a. By entering into this contract, the contractor certifies that neither it nor any person or firm who has an interest in the contractor's firm is a person or firm ineligible to be awarded Government contracts by virtue of [40 U.S.C. 3144\(b\)](#) or § 5.12(a).

b. No part of this contract shall be subcontracted to any person or firm ineligible for award of a Government contract by virtue of [40 U.S.C. 3144\(b\)](#) or § 5.12(a).

c. The penalty for making false statements is prescribed in the U.S. Code, Title 18 Crimes and Criminal Procedure, [18 U.S.C. 1001](#).

11. Anti-retaliation. It is unlawful for any person to discharge, demote, intimidate, threaten, restrain, coerce, blacklist, harass, or in any other manner discriminate against, or to cause any person to discharge, demote, intimidate, threaten, restrain, coerce, blacklist, harass, or in any other manner discriminate against, any worker or job applicant for:

a. Notifying any contractor of any conduct which the worker reasonably believes constitutes a violation of the DBA, Related Acts, this part, or [29 CFR part 1](#) or [3](#);

b. Filing any complaint, initiating or causing to be initiated any proceeding, or otherwise asserting or seeking to assert on behalf of themselves or others any right or protection under the DBA, Related Acts, this part, or [29 CFR part 1](#) or [3](#);

c. Cooperating in any investigation or other compliance action, or testifying in any proceeding under the DBA, Related Acts, this part, or [29 CFR part 1](#) or [3](#); or

d. Informing any other person about their rights under the DBA, Related Acts, this part, or [29 CFR part 1](#) or [3](#).

V. CONTRACT WORK HOURS AND SAFETY STANDARDS ACT

Pursuant to 29 CFR 5.5(b), the following clauses apply to any Federal-aid construction contract in an amount in excess of \$100,000 and subject to the overtime provisions of the Contract Work Hours and Safety Standards Act. These clauses shall be inserted in addition to the clauses required by 29 CFR 5.5(a) or 29 CFR 4.6. As used in this paragraph, the terms laborers and mechanics include watchpersons and guards.

1. Overtime requirements. No contractor or subcontractor contracting for any part of the contract work which may require or involve the employment of laborers or mechanics shall require or permit any such laborer or mechanic in any workweek in which he or she is employed on such work to work in excess of forty hours in such workweek unless such laborer or mechanic receives compensation at a rate not less than one and one-half times the basic rate of pay for all hours worked in excess of forty hours in such workweek. 29 CFR 5.5.

2. Violation; liability for unpaid wages; liquidated damages. In the event of any violation of the clause set forth in paragraph 1. of this section the contractor and any subcontractor responsible therefor shall be liable for the unpaid wages and interest from the date of the underpayment. In addition, such contractor and subcontractor shall be liable to the United States (in the case of work done under contract for the District of Columbia or a territory, to such District or to such territory), for liquidated damages. Such liquidated damages shall be computed with respect to each individual laborer or

mechanic, including watchpersons and guards, employed in violation of the clause set forth in paragraph 1. of this section, in the sum currently provided in 29 CFR 5.5(b)(2)* for each calendar day on which such individual was required or permitted to work in excess of the standard workweek of forty hours without payment of the overtime wages required by the clause set forth in paragraph 1. of this section.

* \$31 as of January 15, 2023 (See 88 FR 88 FR 2210) as may be adjusted annually by the Department of Labor, pursuant to the Federal Civil Penalties Inflation Adjustment Act of 1990.

3. Withholding for unpaid wages and liquidated damages

a. *Withholding process.* The FHWA or the contracting agency may, upon its own action, or must, upon written request of an authorized representative of the Department of Labor, withhold or cause to be withheld from the contractor so much of the accrued payments or advances as may be considered necessary to satisfy the liabilities of the prime contractor or any subcontractor for any unpaid wages; monetary relief, including interest; and liquidated damages required by the clauses set forth in this section on this contract, any other Federal contract with the same prime contractor, or any other federally assisted contract subject to the Contract Work Hours and Safety Standards Act that is held by the same prime contractor (as defined in § 5.2). The necessary funds may be withheld from the contractor under this contract, any other Federal contract with the same prime contractor, or any other federally assisted contract that is subject to the Contract Work Hours and Safety Standards Act and is held by the same prime contractor, regardless of whether the other contract was awarded or assisted by the same agency, and such funds may be used to satisfy the contractor liability for which the funds were withheld.

b. *Priority to withheld funds.* The Department has priority to funds withheld or to be withheld in accordance with Section IV paragraph 2.a. or paragraph 3.a. of this section, or both, over claims to those funds by:

- (1) A contractor's surety(ies), including without limitation performance bond sureties and payment bond sureties;
- (2) A contracting agency for its procurement costs;
- (3) A trustee(s) (either a court-appointed trustee or a U.S. trustee, or both) in bankruptcy of a contractor, or a contractor's bankruptcy estate;
- (4) A contractor's assignee(s);
- (5) A contractor's successor(s); or
- (6) A claim asserted under the Prompt Payment Act, [31 U.S.C. 3901–3907](#).

4. Subcontracts. The contractor or subcontractor must insert in any subcontracts the clauses set forth in paragraphs 1. through 5. of this section and a clause requiring the subcontractors to include these clauses in any lower tier subcontracts. The prime contractor is responsible for compliance by any subcontractor or lower tier subcontractor with the clauses set forth in paragraphs 1. through 5. In the

event of any violations of these clauses, the prime contractor and any subcontractor(s) responsible will be liable for any unpaid wages and monetary relief, including interest from the date of the underpayment or loss, due to any workers of lower-tier subcontractors, and associated liquidated damages and may be subject to debarment, as appropriate.

5. Anti-retaliation. It is unlawful for any person to discharge, demote, intimidate, threaten, restrain, coerce, blacklist, harass, or in any other manner discriminate against, or to cause any person to discharge, demote, intimidate, threaten, restrain, coerce, blacklist, harass, or in any other manner discriminate against, any worker or job applicant for:

a. Notifying any contractor of any conduct which the worker reasonably believes constitutes a violation of the Contract Work Hours and Safety Standards Act (CWHSSA) or its implementing regulations in this part;

b. Filing any complaint, initiating or causing to be initiated any proceeding, or otherwise asserting or seeking to assert on behalf of themselves or others any right or protection under CWHSSA or this part;

c. Cooperating in any investigation or other compliance action, or testifying in any proceeding under CWHSSA or this part; or

d. Informing any other person about their rights under CWHSSA or this part.

VI. SUBLETTING OR ASSIGNING THE CONTRACT

This provision is applicable to all Federal-aid construction contracts on the National Highway System pursuant to 23 CFR 635.116.

1. The contractor shall perform with its own organization contract work amounting to not less than 30 percent (or a greater percentage if specified elsewhere in the contract) of the total original contract price, excluding any specialty items designated by the contracting agency. Specialty items may be performed by subcontract and the amount of any such specialty items performed may be deducted from the total original contract price before computing the amount of work required to be performed by the contractor's own organization (23 CFR 635.116).

a. The term "perform work with its own organization" in paragraph 1 of Section VI refers to workers employed or leased by the prime contractor, and equipment owned or rented by the prime contractor, with or without operators. Such term does not include employees or equipment of a subcontractor or lower tier subcontractor, agents of the prime contractor, or any other assignees. The term may include payments for the costs of hiring leased employees from an employee leasing firm meeting all relevant Federal and State regulatory requirements. Leased employees may only be included in this term if the prime contractor meets all of the following conditions: (based on longstanding interpretation)

- (1) the prime contractor maintains control over the supervision of the day-to-day activities of the leased employees;
- (2) the prime contractor remains responsible for the quality of the work of the leased employees;

- (3) the prime contractor retains all power to accept or exclude individual employees from work on the project; and
- (4) the prime contractor remains ultimately responsible for the payment of predetermined minimum wages, the submission of payrolls, statements of compliance and all other Federal regulatory requirements.

b. "Specialty Items" shall be construed to be limited to work that requires highly specialized knowledge, abilities, or equipment not ordinarily available in the type of contracting organizations qualified and expected to bid or propose on the contract as a whole and in general are to be limited to minor components of the overall contract. 23 CFR 635.102.

2. Pursuant to 23 CFR 635.116(a), the contract amount upon which the requirements set forth in paragraph (1) of Section VI is computed includes the cost of material and manufactured products which are to be purchased or produced by the contractor under the contract provisions.

3. Pursuant to 23 CFR 635.116(c), the contractor shall furnish (a) a competent superintendent or supervisor who is employed by the firm, has full authority to direct performance of the work in accordance with the contract requirements, and is in charge of all construction operations (regardless of who performs the work) and (b) such other of its own organizational resources (supervision, management, and engineering services) as the contracting officer determines is necessary to assure the performance of the contract.

4. No portion of the contract shall be sublet, assigned or otherwise disposed of except with the written consent of the contracting officer, or authorized representative, and such consent when given shall not be construed to relieve the contractor of any responsibility for the fulfillment of the contract. Written consent will be given only after the contracting agency has assured that each subcontract is evidenced in writing and that it contains all pertinent provisions and requirements of the prime contract. (based on long-standing interpretation of 23 CFR 635.116).

5. The 30-percent self-performance requirement of paragraph (1) is not applicable to design-build contracts; however, contracting agencies may establish their own self-performance requirements. 23 CFR 635.116(d).

VII. SAFETY: ACCIDENT PREVENTION

This provision is applicable to all Federal-aid construction contracts and to all related subcontracts.

1. In the performance of this contract the contractor shall comply with all applicable Federal, State, and local laws governing safety, health, and sanitation (23 CFR Part 635). The contractor shall provide all safeguards, safety devices and protective equipment and take any other needed actions as it determines, or as the contracting officer may determine, to be reasonably necessary to protect the life and health of employees on the job and the safety of the public and to protect property in connection with the performance of the work covered by the contract. 23 CFR 635.108.

2. It is a condition of this contract, and shall be made a condition of each subcontract, which the contractor enters into pursuant to this contract, that the contractor and any subcontractor shall not permit any employee, in performance of the contract, to work in surroundings or under conditions which are unsanitary, hazardous or dangerous to his/her health or safety, as determined under construction safety and

health standards (29 CFR Part 1926) promulgated by the Secretary of Labor, in accordance with Section 107 of the Contract Work Hours and Safety Standards Act (40 U.S.C. 3704). 29 CFR 1926.10.

3. Pursuant to 29 CFR 1926.3, it is a condition of this contract that the Secretary of Labor or authorized representative thereof, shall have right of entry to any site of contract performance to inspect or investigate the matter of compliance with the construction safety and health standards and to carry out the duties of the Secretary under Section 107 of the Contract Work Hours and Safety Standards Act (40 U.S.C. 3704).

VIII. FALSE STATEMENTS CONCERNING HIGHWAY PROJECTS

This provision is applicable to all Federal-aid construction contracts and to all related subcontracts.

In order to assure high quality and durable construction in conformity with approved plans and specifications and a high degree of reliability on statements and representations made by engineers, contractors, suppliers, and workers on Federal-aid highway projects, it is essential that all persons concerned with the project perform their functions as carefully, thoroughly, and honestly as possible. Willful falsification, distortion, or misrepresentation with respect to any facts related to the project is a violation of Federal law. To prevent any misunderstanding regarding the seriousness of these and similar acts, Form FHWA-1022 shall be posted on each Federal-aid highway project (23 CFR Part 635) in one or more places where it is readily available to all persons concerned with the project:

18 U.S.C. 1020 reads as follows:

"Whoever, being an officer, agent, or employee of the United States, or of any State or Territory, or whoever, whether a person, association, firm, or corporation, knowingly makes any false statement, false representation, or false report as to the character, quality, quantity, or cost of the material used or to be used, or the quantity or quality of the work performed or to be performed, or the cost thereof in connection with the submission of plans, maps, specifications, contracts, or costs of construction on any highway or related project submitted for approval to the Secretary of Transportation; or

Whoever knowingly makes any false statement, false representation, false report or false claim with respect to the character, quality, quantity, or cost of any work performed or to be performed, or materials furnished or to be furnished, in connection with the construction of any highway or related project approved by the Secretary of Transportation; or

Whoever knowingly makes any false statement or false representation as to material fact in any statement, certificate, or report submitted pursuant to provisions of the Federal-aid Roads Act approved July 11, 1916, (39 Stat. 355), as amended and supplemented;

Shall be fined under this title or imprisoned not more than 5 years or both."

IX. IMPLEMENTATION OF CLEAN AIR ACT AND FEDERAL WATER POLLUTION CONTROL ACT (42 U.S.C. 7606; 2 CFR 200.88; EO 11738)

This provision is applicable to all Federal-aid construction contracts in excess of \$150,000 and to all related subcontracts. 48 CFR 2.101; 2 CFR 200.327.

By submission of this bid/proposal or the execution of this contract or subcontract, as appropriate, the bidder, proposer, Federal-aid construction contractor, subcontractor, supplier, or vendor agrees to comply with all applicable standards, orders or regulations issued pursuant to the Clean Air Act (42 U.S.C. 7401-7671q) and the Federal Water Pollution Control Act, as amended (33 U.S.C. 1251-1387). Violations must be reported to the Federal Highway Administration and the Regional Office of the Environmental Protection Agency. 2 CFR Part 200, Appendix II.

The contractor agrees to include or cause to be included the requirements of this Section in every subcontract, and further agrees to take such action as the contracting agency may direct as a means of enforcing such requirements. 2 CFR 200.327.

X. CERTIFICATION REGARDING DEBARMENT, SUSPENSION, INELIGIBILITY AND VOLUNTARY EXCLUSION

This provision is applicable to all Federal-aid construction contracts, design-build contracts, subcontracts, lower-tier subcontracts, purchase orders, lease agreements, consultant contracts or any other covered transaction requiring FHWA approval or that is estimated to cost \$25,000 or more – as defined in 2 CFR Parts 180 and 1200. 2 CFR 180.220 and 1200.220.

1. Instructions for Certification – First Tier Participants:

a. By signing and submitting this proposal, the prospective first tier participant is providing the certification set out below.

b. The inability of a person to provide the certification set out below will not necessarily result in denial of participation in this covered transaction. The prospective first tier participant shall submit an explanation of why it cannot provide the certification set out below. The certification or explanation will be considered in connection with the department or agency's determination whether to enter into this transaction. However, failure of the prospective first tier participant to furnish a certification or an explanation shall disqualify such a person from participation in this transaction. 2 CFR 180.320.

c. The certification in this clause is a material representation of fact upon which reliance was placed when the contracting agency determined to enter into this transaction. If it is later determined that the prospective participant knowingly rendered an erroneous certification, in addition to other remedies available to the Federal Government, the contracting agency may terminate this transaction for cause of default. 2 CFR 180.325.

d. The prospective first tier participant shall provide immediate written notice to the contracting agency to whom this proposal is submitted if any time the prospective first tier participant learns that its certification was erroneous when submitted or has become erroneous by reason of changed circumstances. 2 CFR 180.345 and 180.350.

e. The terms "covered transaction," "debarred," "suspended," "ineligible," "participant," "person," "principal," and "voluntarily excluded," as used in this clause, are defined in 2 CFR Parts 180, Subpart I, 180.900-180.1020, and 1200. "First Tier Covered Transactions" refers to any covered transaction between a recipient or subrecipient of Federal funds and a participant (such as the prime or general contract). "Lower Tier Covered Transactions" refers to any covered transaction under a First Tier Covered Transaction (such as subcontracts). "First Tier Participant" refers to the participant who has entered into a covered transaction with a recipient or subrecipient of Federal funds (such as the prime or general contractor). "Lower Tier Participant" refers any participant who has entered into a covered transaction with a First Tier Participant or other Lower Tier Participants (such as subcontractors and suppliers).

f. The prospective first tier participant agrees by submitting this proposal that, should the proposed covered transaction be entered into, it shall not knowingly enter into any lower tier covered transaction with a person who is debarred, suspended, declared ineligible, or voluntarily excluded from participation in this covered transaction, unless authorized by the department or agency entering into this transaction. 2 CFR 180.330.

g. The prospective first tier participant further agrees by submitting this proposal that it will include the clause titled "Certification Regarding Debarment, Suspension, Ineligibility and Voluntary Exclusion-Lower Tier Covered Transactions," provided by the department or contracting agency, entering into this covered transaction, without modification, in all lower tier covered transactions and in all solicitations for lower tier covered transactions exceeding the \$25,000 threshold. 2 CFR 180.220 and 180.300.

h. A participant in a covered transaction may rely upon a certification of a prospective participant in a lower tier covered transaction that is not debarred, suspended, ineligible, or voluntarily excluded from the covered transaction, unless it knows that the certification is erroneous. 2 CFR 180.300; 180.320, and 180.325. A participant is responsible for ensuring that its principals are not suspended, debarred, or otherwise ineligible to participate in covered transactions. 2 CFR 180.335. To verify the eligibility of its principals, as well as the eligibility of any lower tier prospective participants, each participant may, but is not required to, check the System for Award Management website (<https://www.sam.gov/>). 2 CFR 180.300, 180.320, and 180.325.

i. Nothing contained in the foregoing shall be construed to require the establishment of a system of records in order to render in good faith the certification required by this clause. The knowledge and information of the prospective participant is not required to exceed that which is normally possessed by a prudent person in the ordinary course of business dealings.

j. Except for transactions authorized under paragraph (f) of these instructions, if a participant in a covered transaction knowingly enters into a lower tier covered transaction with a person who is suspended, debarred, ineligible, or voluntarily excluded from participation in this transaction, in addition to other remedies available to the Federal Government, the department or agency may terminate this transaction for cause or default. 2 CFR 180.325.

2. Certification Regarding Debarment, Suspension, Ineligibility and Voluntary Exclusion – First Tier Participants:

a. The prospective first tier participant certifies to the best of its knowledge and belief, that it and its principals:

(1) Are not presently debarred, suspended, proposed for debarment, declared ineligible, or voluntarily excluded from participating in covered transactions by any Federal department or agency, 2 CFR 180.335;

(2) Have not within a three-year period preceding this proposal been convicted of or had a civil judgment rendered against them for commission of fraud or a criminal offense in connection with obtaining, attempting to obtain, or performing a public (Federal, State, or local) transaction or contract under a public transaction; violation of Federal or State antitrust statutes or commission of embezzlement, theft, forgery, bribery, falsification or destruction of records, making false statements, or receiving stolen property, 2 CFR 180.800;

(3) Are not presently indicted for or otherwise criminally or civilly charged by a governmental entity (Federal, State or local) with commission of any of the offenses enumerated in paragraph (a)(2) of this certification, 2 CFR 180.700 and 180.800; and

(4) Have not within a three-year period preceding this application/proposal had one or more public transactions (Federal, State or local) terminated for cause or default. 2 CFR 180.335(d).

(5) Are not a corporation that has been convicted of a felony violation under any Federal law within the two-year period preceding this proposal (USDOT Order 4200.6 implementing appropriations act requirements); and

(6) Are not a corporation with any unpaid Federal tax liability that has been assessed, for which all judicial and administrative remedies have been exhausted, or have lapsed, and that is not being paid in a timely manner pursuant to an agreement with the authority responsible for collecting the tax liability (USDOT Order 4200.6 implementing appropriations act requirements).

b. Where the prospective participant is unable to certify to any of the statements in this certification, such prospective participant should attach an explanation to this proposal. 2 CFR 180.335 and 180.340.

3. Instructions for Certification - Lower Tier Participants:

(Applicable to all subcontracts, purchase orders, and other lower tier transactions requiring prior FHWA approval or estimated to cost \$25,000 or more - 2 CFR Parts 180 and 1200). 2 CFR 180.220 and 1200.220.

a. By signing and submitting this proposal, the prospective lower tier participant is providing the certification set out below.

b. The certification in this clause is a material representation of fact upon which reliance was placed when this transaction was entered into. If it is later determined that the prospective lower tier participant knowingly rendered an erroneous certification, in addition to other remedies available to the Federal Government, the department, or agency with which

this transaction originated may pursue available remedies, including suspension and/or debarment.

c. The prospective lower tier participant shall provide immediate written notice to the person to which this proposal is submitted if at any time the prospective lower tier participant learns that its certification was erroneous by reason of changed circumstances. 2 CFR 180.365.

d. The terms "covered transaction," "debarred," "suspended," "ineligible," "participant," "person," "principal," and "voluntarily excluded," as used in this clause, are defined in 2 CFR Parts 180, Subpart I, 180.900 – 180.1020, and 1200. You may contact the person to which this proposal is submitted for assistance in obtaining a copy of those regulations. "First Tier Covered Transactions" refers to any covered transaction between a recipient or subrecipient of Federal funds and a participant (such as the prime or general contract). "Lower Tier Covered Transactions" refers to any covered transaction under a First Tier Covered Transaction (such as subcontracts). "First Tier Participant" refers to the participant who has entered into a covered transaction with a recipient or subrecipient of Federal funds (such as the prime or general contractor). "Lower Tier Participant" refers any participant who has entered into a covered transaction with a First Tier Participant or other Lower Tier Participants (such as subcontractors and suppliers).

e. The prospective lower tier participant agrees by submitting this proposal that, should the proposed covered transaction be entered into, it shall not knowingly enter into any lower tier covered transaction with a person who is debarred, suspended, declared ineligible, or voluntarily excluded from participation in this covered transaction, unless authorized by the department or agency with which this transaction originated. 2 CFR 1200.220 and 1200.332.

f. The prospective lower tier participant further agrees by submitting this proposal that it will include this clause titled "Certification Regarding Debarment, Suspension, Ineligibility and Voluntary Exclusion-Lower Tier Covered Transaction," without modification, in all lower tier covered transactions and in all solicitations for lower tier covered transactions exceeding the \$25,000 threshold. 2 CFR 180.220 and 1200.220.

g. A participant in a covered transaction may rely upon a certification of a prospective participant in a lower tier covered transaction that is not debarred, suspended, ineligible, or voluntarily excluded from the covered transaction, unless it knows that the certification is erroneous. A participant is responsible for ensuring that its principals are not suspended, debarred, or otherwise ineligible to participate in covered transactions. To verify the eligibility of its principals, as well as the eligibility of any lower tier prospective participants, each participant may, but is not required to, check the System for Award Management website (<https://www.sam.gov/>), which is compiled by the General Services Administration. 2 CFR 180.300, 180.320, 180.330, and 180.335.

h. Nothing contained in the foregoing shall be construed to require establishment of a system of records in order to render in good faith the certification required by this clause. The knowledge and information of participant is not required to exceed that which is normally possessed by a prudent person in the ordinary course of business dealings.

i. Except for transactions authorized under paragraph e of these instructions, if a participant in a covered transaction knowingly enters into a lower tier covered transaction with a person who is suspended, debarred, ineligible, or voluntarily

excluded from participation in this transaction, in addition to other remedies available to the Federal Government, the department or agency with which this transaction originated may pursue available remedies, including suspension and/or debarment. 2 CFR 180.325.

* * * * *

4. Certification Regarding Debarment, Suspension, Ineligibility and Voluntary Exclusion--Lower Tier Participants:

a. The prospective lower tier participant certifies, by submission of this proposal, that neither it nor its principals:

(1) is presently debarred, suspended, proposed for debarment, declared ineligible, or voluntarily excluded from participating in covered transactions by any Federal department or agency, 2 CFR 180.355;

(2) is a corporation that has been convicted of a felony violation under any Federal law within the two-year period preceding this proposal (USDOT Order 4200.6 implementing appropriations act requirements); and

(3) is a corporation with any unpaid Federal tax liability that has been assessed, for which all judicial and administrative remedies have been exhausted, or have lapsed, and that is not being paid in a timely manner pursuant to an agreement with the authority responsible for collecting the tax liability. (USDOT Order 4200.6 implementing appropriations act requirements)

b. Where the prospective lower tier participant is unable to certify to any of the statements in this certification, such prospective participant should attach an explanation to this proposal.

* * * * *

XI. CERTIFICATION REGARDING USE OF CONTRACT FUNDS FOR LOBBYING

This provision is applicable to all Federal-aid construction contracts and to all related subcontracts which exceed \$100,000. 49 CFR Part 20, App. A.

1. The prospective participant certifies, by signing and submitting this bid or proposal, to the best of his or her knowledge and belief, that:

a. No Federal appropriated funds have been paid or will be paid, by or on behalf of the undersigned, to any person for influencing or attempting to influence an officer or employee of any Federal agency, a Member of Congress, an officer or employee of Congress, or an employee of a Member of Congress in connection with the awarding of any Federal contract, the making of any Federal grant, the making of any Federal loan, the entering into of any cooperative agreement, and the extension, continuation, renewal, amendment, or modification of any Federal contract, grant, loan, or cooperative agreement.

b. If any funds other than Federal appropriated funds have been paid or will be paid to any person for influencing or attempting to influence an officer or employee of any Federal agency, a Member of Congress, an officer or employee of Congress, or an employee of a Member of Congress in connection with this Federal contract, grant, loan, or

cooperative agreement, the undersigned shall complete and submit Standard Form-LLL, "Disclosure Form to Report Lobbying," in accordance with its instructions.

2. This certification is a material representation of fact upon which reliance was placed when this transaction was made or entered into. Submission of this certification is a prerequisite for making or entering into this transaction imposed by 31 U.S.C. 1352. Any person who fails to file the required certification shall be subject to a civil penalty of not less than \$10,000 and not more than \$100,000 for each such failure.

3. The prospective participant also agrees by submitting its bid or proposal that the participant shall require that the language of this certification be included in all lower tier subcontracts, which exceed \$100,000 and that all such recipients shall certify and disclose accordingly.

XII. USE OF UNITED STATES-FLAG VESSELS:

This provision is applicable to all Federal-aid construction contracts, design-build contracts, subcontracts, lower-tier subcontracts, purchase orders, lease agreements, or any other covered transaction. 46 CFR Part 381.

This requirement applies to material or equipment that is acquired for a specific Federal-aid highway project. 46 CFR 381.7. It is not applicable to goods or materials that come into inventories independent of an FHWA funded-contract.

When oceanic shipments (or shipments across the Great Lakes) are necessary for materials or equipment acquired for a specific Federal-aid construction project, the bidder, proposer, contractor, subcontractor, or vendor agrees:

1. To utilize privately owned United States-flag commercial vessels to ship at least 50 percent of the gross tonnage (computed separately for dry bulk carriers, dry cargo liners, and tankers) involved, whenever shipping any equipment, material, or commodities pursuant to this contract, to the extent such vessels are available at fair and reasonable rates for United States-flag commercial vessels. 46 CFR 381.7.

2. To furnish within 20 days following the date of loading for shipments originating within the United States or within 30 working days following the date of loading for shipments originating outside the United States, a legible copy of a rated, 'on-board' commercial ocean bill-of-lading in English for each shipment of cargo described in paragraph (b)(1) of this section to both the Contracting Officer (through the prime contractor in the case of subcontractor bills-of-lading) and to the Office of Cargo and Commercial Sealift (MAR-620), Maritime Administration, Washington, DC 20590. (MARAD requires copies of the ocean carrier's (master) bills of lading, certified onboard, dated, with rates and charges. These bills of lading may contain business sensitive information and therefore may be submitted directly to MARAD by the Ocean Transportation Intermediary on behalf of the contractor). 46 CFR 381.7.

**ATTACHMENT A - EMPLOYMENT AND MATERIALS
PREFERENCE FOR APPALACHIAN DEVELOPMENT
HIGHWAY SYSTEM OR APPALACHIAN LOCAL ACCESS
ROAD CONTRACTS (23 CFR 633, Subpart B, Appendix B)**

This provision is applicable to all Federal-aid projects funded under the Appalachian Regional Development Act of 1965.

1. During the performance of this contract, the contractor undertaking to do work which is, or reasonably may be, done as on-site work, shall give preference to qualified persons who regularly reside in the labor area as designated by the DOL wherein the contract work is situated, or the subregion, or the Appalachian counties of the State wherein the contract work is situated, except:

a. To the extent that qualified persons regularly residing in the area are not available.

b. For the reasonable needs of the contractor to employ supervisory or specially experienced personnel necessary to assure an efficient execution of the contract work.

c. For the obligation of the contractor to offer employment to present or former employees as the result of a lawful collective bargaining contract, provided that the number of nonresident persons employed under this subparagraph (1c) shall not exceed 20 percent of the total number of employees employed by the contractor on the contract work, except as provided in subparagraph (4) below.

2. The contractor shall place a job order with the State Employment Service indicating (a) the classifications of the laborers, mechanics and other employees required to perform the contract work, (b) the number of employees required in each classification, (c) the date on which the participant estimates such employees will be required, and (d) any other pertinent information required by the State Employment Service to complete the job order form. The job order may be placed with the State Employment Service in writing or by telephone. If during the course of the contract work, the information submitted by the contractor in the original job order is substantially modified, the participant shall promptly notify the State Employment Service.

3. The contractor shall give full consideration to all qualified job applicants referred to him by the State Employment Service. The contractor is not required to grant employment to any job applicants who, in his opinion, are not qualified to perform the classification of work required.

4. If, within one week following the placing of a job order by the contractor with the State Employment Service, the State Employment Service is unable to refer any qualified job applicants to the contractor, or less than the number requested, the State Employment Service will forward a certificate to the contractor indicating the unavailability of applicants. Such certificate shall be made a part of the contractor's permanent project records. Upon receipt of this certificate, the contractor may employ persons who do not normally reside in the labor area to fill positions covered by the certificate, notwithstanding the provisions of subparagraph (1c) above.

5. The provisions of 23 CFR 633.207(e) allow the contracting agency to provide a contractual preference for the use of mineral resource materials native to the Appalachian region.

6. The contractor shall include the provisions of Sections 1 through 4 of this Attachment A in every subcontract for work which is, or reasonably may be, done as on-site work.

SECTION IV

Bid Proposal and Bid Guaranty

BIDDER'S CHECKLIST

PROJECT NO. 2023-05

WAR-TR55-2.11, Deerfield Township

Required Submittals

- Non-Collusion Affidavit
- Affidavit Affirming Compliance with 9.24 and 5719.042 ORC
- Bid Proposal
- Worksheet with line item unit prices
- Addenda (if applies)

Bid Guaranty

(Select only one)

- Certified Check (10% of Bid)
- Cashier's Check (10% of Bid)
- Irrevocable letter of Credit (10% of Bid)
- Bid Guaranty and Contract Bond, Combination (100% of Bid)

If Using Bid Guaranty and Contract Bond

- Signed by Bidder & Surety Agent
- Power of Attorney – Proper Agent Name and Date
- Current Financial Statement of Surety
- Current Certificate of Insurance for Surety from Department of Insurance

Additional Reminders

- Reviewed Proposal and worksheets for mathematical errors
- All information supplied in duplicate

This checklist is not intended to relieve the Bidder of the responsibility to provide other required documents. Rather, this checklist is offered merely to serve as an aid in assisting in the preparation of the bid. Notice is hereby given that the failure to submit all required documents duly and properly constituted including but not limited to all required signatures may result in the rejection of your bid on the basis that the bid is non-responsive.

BID PROPOSAL

PROJECT NO. 2023-05

WAR-TR55-2.11, Deerfield Township, Warren County, Ohio

TO THE WARREN COUNTY TRANSPORTATION IMPROVEMENT DISTRICT :

The undersigned certifies that he/she has examined the Plans and Specifications and has inspected the site of the proposed improvements. It is understood that the following bid will be governed by the UNIT PRICE BID, unless otherwise specified, also that the quantities may be increased or decreased, if the bid is a unit price bid.

The undersigned submits with the following bid a bid guarantee for the amount, as set forth in Section 200.5 of the General Provisions, and proposes to furnish all labor, equipment, and materials necessary for the construction of PROJECT NO. 2023-05: **WAR-TR55-2.11** in accordance with the Ohio Department of Transportation Construction and Material Specifications, Standard Construction Drawings, Ohio Manual of Uniform Traffic Control, The Ohio Department of Transportation Bridge Design manual, and the Technical Specifications contained in the Construction Drawings, under the most current versions of the aforementioned drawings and specifications and in force on the date of letting shall be enforced by the Warren County Transportation Improvement District:

PROJECT NO. 2023-05, WAR-TR55-2.11

TOTAL ENGINEER'S ESTIMATE: \$ 850,000.00

Please enter the total cost of the Bid Proposal, OBTAINED FROM THE ATTACHED WORKSHEET(S), in the space below:

TOTAL BID AMOUNT: _____

Amount of Guaranty: Each Proposal must be accompanied by a bond in the sum of One Hundred (100) percent (%) of the Bid Amount or a CERTIFIED CHECK, CASHIER'S CHECK, OR IRREVOCABLE LETTER OF CREDIT pursuant to Chapter 1305 of the Ohio Revised Code in the sum of ten (10) percent (%) of the Bid Amount on a solvent bank as a guarantee that if the Proposal is accepted a contract will be entered into.

BID OPENING DATE: **Thursday December 14th, 2023**
BIDS RECEIVED BY: **11:00 A.M. Local Time**

DATE OF COMPLETION: **December 31st, 2024**

The undersigned hereby acknowledges receipt of the following addenda:

Project No. 2023-05

Addendum No. _____ Date _____

Addendum No. _____ Date _____

Addendum No. _____ Date _____

Addendum No. _____ Date _____

It is understood that if this bid is accepted, the undersigned will enter into a contract and give bond with approved security in the full amount of the bid within ten (10) days after the award of the contract by the Warren County Transportation Improvement District, otherwise the Bid Guarantee will be forfeited.

Witness our hands this _____ day of _____, 2024

NAME OF BIDDER:

(COMPANY OR CORPORATION)

(SIGNATURE OF AGENT)

BID GUARANTY AND CONTRACT BOND

KNOW ALL MEN BY THESE PRESENTS, that we, the undersigned _____ as Principal and _____ as Surety, are hereby held and firmly bound unto The Warren County Transportation Improvement District and Ohio Department of Transportation, herein after called the Obligee, in the penal sum of the dollar amount of the bid submitted by the Principal to the Obligee, on _____, 20____ to undertake the Project known as:

PROJECT NO. 2023-05, WAR-TR55-2.11

The penal sum referred to herein shall be the dollar amount of the Principal's bid to the Obligee, incorporating any additive or deductive alternate proposals made by the Principal on the date referred to above to the Obligee, which are accepted by the Obligee. In no case shall the penal sum exceed the amount of _____ dollars (\$_____). (If the above line is left blank, the penal sum will be the full amount of the Principal's bid, including alternates. Alternatively, if completed, the amount stated must not be less than the full amount of the bid, including alternates, in dollars and cents. A percentage is not acceptable.) For the payment of the penal sum well and truly to be made, we hereby jointly and severally bind ourselves, our heirs, executors, administrators, successors, and assigns.

THE CONDITION OF THE ABOVE OBLIGATION IS SUCH, that whereas the above named Principal has submitted a bid on the above referred to project.

NOW, THEREFORE, if the Obligee accepts the bid of the Principal and the Principal fails to enter into a proper contract in accordance with the bid, plans, details, specifications, and bills of material; and in the event the Principal pays to the Obligee the difference not to exceed ten percent to the penalty hereof between the amount specified in the bid and such larger amount for which the Obligee may in good faith contract with the next Bidder to perform the work covered by the bid; or in the event the Obligee does not award the Contract to the next lowest Bidder and resubmits the project for bidding, the Principal will pay the Obligee the difference not to exceed ten percent of the penalty hereof between the amount specified in the bid, or the costs, in connection with the resubmission, of printing new contract documents, required advertising and printing and mailing notices to prospective Bidders, whichever is less, then this obligation shall be void, otherwise to remain in full force and effect. If the Obligee accepts the bid of the Principal and the Principal, within ten days after the awarding of the contract, enters into a proper contract in accordance with the bid, plans, details, specifications, and bills of material, which said contract is made a part of this bond the same as though set forth herein; and IF THE SAID Principal shall well and faithfully perform each and every condition of such contract; and indemnify the Warren County Transportation Improvement District against all damage suffered by failure to perform such contract according to the provisions thereof and in accordance with the plans, details, specifications and bills of material, therefore; and shall pay all lawful claims of subcontractors, materialmen, and laborers, for labor performed and materials furnished in the carrying forward, performing, or completing of said contract, we agreeing and assenting that this undertaking shall be for the benefit of any materialman or laborer having a just claim, as well as for the Obligee herein; then this obligation shall be void; otherwise the same shall remain in full force and effect; it being expressly understood and agreed that the liability of the Surety for any and all claim hereunder shall in no event exceed the penal amount of this obligation as herein stated.

THE SAID Surety hereby stipulates and agrees that no modifications, omissions, or additions, in or to the terms of said contract or in or to the plans or specifications therefore shall in any way affect the obligations of said Surety on this bond, and it does hereby waive notice of any such modifications, omissions or additions to the terms of the contract or to the work or to the specifications.

SIGNED AND SEALED this _____ day of _____, 20_____.

Principal

By: _____
(Seal)

Surety

By: _____
Attorney/Attorney-In-Fact

(SEAL)

Awarding authorities are simultaneously, with notice of award to Contractor, to give written notice to Surety and Agent. Show name and mailing address of both Agent and Surety.

Surety's Address:

Agent's Address:

SECTION V

Affidavits

**AFFIDAVIT IN COMPLIANCE WITH SECTIONS 9.24 AND 5719.042 OF THE OHIO
REVISED CODE**

WARREN COUNTY, OHIO

PROJECT NO. 2023-05, WAR-TR55-2.11

(PLEASE TYPE OR PRINT NAME OF FIRM)

(AGENT/OWNER FOR FIRM)

personally appeared before me, the undersigned, a Bidder in competitive bidding for a Construction Contract to be let by the Warren County Transportation Improvement District, who, being duly cautioned and sworn, makes the following statement with respect to the personal property taxes on the general tax list of personal property of Warren County, Ohio:

- (1) That the above mentioned firm and its owner/agent at the time of making his/her Bid (Proposal) on the aforementioned Contract was not charged with any delinquent personal property taxes on the general tax list of personal property of Warren County, Ohio.
- (2) That this statement is made in compliance with Section 5719.042 of the Ohio Revised Code to be incorporated into the Contract between the parties as provided in Section 5719.042 of the Ohio Revised Code.
- (3) That pursuant to §9.24 of the Ohio Revised Code, if the project for which this bid is submitted has been identified as being funded in whole or in part with funds from the State of Ohio, the affiant further certifies that the Bidder, if an individual, or if a corporation, any principal owning more than 10% equitable interest in the corporation, does not have a finding for recovery issued by the Auditor of State which remains unresolved as defined in §9.24 ORC.

(SIGNATURE)

(TITLE/POSITION)

Sworn to me this _____, day of _____, 2023.

(NOTARY PUBLIC)

My Commission expires on _____, _____.

(SEAL)

**NON-COLLUSION AFFIDAVIT OF PRIME BIDDER
WARREN COUNTY, OHIO**

PROJECT NO. 2023-05, WAR-TR55-2.11

(PLEASE TYPE OR PRINT FULL NAME) (TITLE/POSITION)

being duly sworn, do depose and say the following:

1. He/She is _____,
(OWNER/AGENT) (TITLE/POSITION)
the Bidder that has submitted the attached Bid or Proposal;
2. He/She is fully informed respecting the preparation and contents of the attached Bid and of all pertinent circumstances respecting such Bid (Proposal);
3. Such Bid (Proposal) is genuine and is not a collusive or sham Bid (Proposal);
4. Neither the said Bidder nor any of its officers, partners, owners, agents, representatives, employees or parties in interest, including this Affiant, has in any way colluded, conspired, connived or agreed, directly or indirectly with any other Bidder, firm or person to submit a collusive or sham Bid (Proposal) in connection with the Contract for which the attached Bid (Proposal) has been submitted or to refrain from bidding in connection with such Contract or has in any manner, directly or indirectly, sought by agreement or collusion or communication or conference with any other Bidder, firm or person, to fix the price or prices in the attached Bid or of any other Bidder or to fix any overhead, profit or cost element of the Bid Price or Bid Price of any other Bidder, or to secure through any collusion, conspiracy, connivance, or unlawful agreement any advantage against the Warren County Transportation Improvement District or any person interested in the proposed Contract;
5. The price or prices quoted in the attached Bid (Proposal) are fair and proper and are not tainted by any collusion, conspiracy, connivance or unlawful agreement on the Part of the Bidder or any of its agents, representatives, owners, employees, or parties in interest, including this Affiant.

(SIGNATURE)

(TITLE/POSITION)

Sworn to me this _____, day of _____, 2023.

(NOTARY PUBLIC)

My Commission expires on _____.

(SEAL)

SECTION VI

Prevailing Wage Rates

"General Decision Number: OH20230001 09/01/2023

Superseded General Decision Number: OH20220001

State: Ohio

Construction Types: Heavy and Highway

Counties: Ohio Statewide.

Heavy and Highway Construction Projects

Note: Contracts subject to the Davis-Bacon Act are generally required to pay at least the applicable minimum wage rate required under Executive Order 14026 or Executive Order 13658. Please note that these Executive Orders apply to covered contracts entered into by the federal government that are subject to the Davis-Bacon Act itself, but do not apply to contracts subject only to the Davis-Bacon Related Acts, including those set forth at 29 CFR 5.1(a)(2)-(60).

<p>If the contract is entered into on or after January 30, 2022, or the contract is renewed or extended (e.g., an option is exercised) on or after January 30, 2022:</p>	<ul style="list-style-type: none"> . Executive Order 14026 generally applies to the contract. . The contractor must pay all covered workers at least \$16.20 per hour (or the applicable wage rate listed on this wage determination, if it is higher) for all hours spent performing on the contract in 2023.
<p>If the contract was awarded on or between January 1, 2015 and January 29, 2022, and the contract is not renewed or extended on or after January 30, 2022:</p>	<ul style="list-style-type: none"> . Executive Order 13658 generally applies to the contract. . The contractor must pay all covered workers at least \$12.15 per hour (or the applicable wage rate listed on this wage determination, if it is higher) for all hours spent performing on that contract in 2023.

The applicable Executive Order minimum wage rate will be adjusted annually. If this contract is covered by one of the Executive Orders and a classification considered necessary for performance of work on the contract does not appear on this wage determination, the contractor must still submit a conformance request.

Additional information on contractor requirements and worker protections under the Executive Orders is available at <http://www.dol.gov/whd/govcontracts>.

Modification Number	Publication Date
0	01/06/2023
1	02/03/2023
2	03/03/2023

3	04/14/2023
4	06/30/2023
5	07/14/2023
6	08/04/2023
7	09/01/2023

BROH0001-001 06/01/2022

DEFIANCE, FULTON (Excluding Fulton, Amboy & Swan Creek Townships), HENRY (Excluding Monroe, Bartlow, Liberty, Washington, Richfield, Marion, Damascus & Townships & that part of Harrison Township outside corporate limits of city of Napoleon), PAULDING, PUTNAM and WILLIAMS COUNTIES

	Rates	Fringes
Bricklayer, Stonemason.....	\$ 31.40	18.55

BROH0001-004 06/01/2022

	Rates	Fringes
CEMENT MASON/CONCRETE FINISHER...	\$ 31.40	18.55

BROH0003-002 06/01/2022

FULTON (Townships of Amboy, Swan Creek & Fulton), HENRY (Townships of Washington, Damascus, Richfield, Bartlow, Liberty, Harrison, Monroe, & Marion), LUCAS and WOOD (Townships of Perrysburg, Ross, Lake, Troy, Freedom, Montgomery, Webster, Center, Portage, Middleton, Plain, Liberty, Henry, Washington, Weston, Milton, Jackson & Grand Rapids) COUNTIES

	Rates	Fringes
Bricklayer, Stonemason.....	\$ 31.40	18.55

BROH0005-003 06/01/2020

CUYAHOGA, LORAIN & MEDINA (Hinckley, Granger, Brunswick, Liverpool, Montville, York, Homer, Harrisville, Chatham, Litchfield & Spencer Townships and the city of Medina)

	Rates	Fringes
BRICKLAYER		
BRICKLAYERS; CAULKERS;		
CLEANERS; POINTERS; &		
STONEMASONS.....	\$ 36.64	17.13
SANDBLASTERS.....	\$ 36.39	17.13
SEWER BRICKLAYERS & STACK		
BUILDERS.....	\$ 36.64	17.13
SWING SCAFFOLDS.....	\$ 37.14	17.13

BROH0006-005 06/01/2022

CARROLL, COLUMBIANA (Knox, Butler, West & Hanover Townships), STARK & TUSCARAWAS

Rates	Fringes
-------	---------

Bricklayer, Stonemason.....\$ 31.40 18.55

BROH0007-002 06/01/2022

LAWRENCE

Rates Fringes

Bricklayer, Stonemason.....\$ 31.40 18.55

BROH0007-005 06/01/2022

PORTAGE & SUMMIT

Rates Fringes

BRICKLAYER.....\$ 31.40 18.55

BROH0007-010 06/01/2017

PORTAGE & SUMMIT

Rates Fringes

MASON - STONE.....\$ 28.65 14.55

BROH0008-001 06/01/2022

COLUMBIANA (Salem, Perry, Fairfield, Center, Elk Run, Middleton, & Unity Townships and the city of New Waterford), MAHONING & TRUMBULL

Rates Fringes

BRICKLAYER.....\$ 31.40 18.55

BROH0009-002 06/01/2022

BELMONT & MONROE COUNTIES and the Townships of Warren & Mt. Pleasant and the Village of Dillonvale in JEFFERSON COUNTY

Rates Fringes

Bricklayer, Stonemason.....\$ 31.40 18.55
Refractory.....\$ 31.45 19.01

BROH0010-002 06/01/2022

COLUMBIANA (St. Clair, Madison, Wayne, Franklin, Washington, Yellow Creek & Liverpool Townships) & JEFFERSON (Brush Creek & Saline Townships)

Rates Fringes

Bricklayer, Stonemason.....\$ 31.40 18.55

BROH0014-002 06/01/2022

HARRISON & JEFFERSON (Except Mt. Pleasant, Warren, Brush Creek, Saline & Salineville Townships & the Village of Dillonvale)

	Rates	Fringes
Bricklayer, Stonemason.....	\$ 31.40	18.55

BROH0016-002 06/01/2022

ASHTABULA, GEAUGA, and LAKE COUNTIES

	Rates	Fringes
Bricklayer, Stonemason.....	\$ 31.40	18.55

BROH0018-002 06/01/2022

BROWN, BUTLER, CLERMONT, HAMILTON, PREBLE (Gasper, Dixon, Israel, Lanier, Somers & Gratis Townships) & WARREN COUNTIES:

	Rates	Fringes
Bricklayer, Stonemason.....	\$ 31.40	18.55

BROH0022-004 06/01/2022

CHAMPAIGN, CLARK, CLINTON, DARKE, GREENE, HIGHLAND, LOGAN, MIAMI, MONTGOMERY, PREBLE (Jackson, Monroe, Harrison, Twin, Jefferson & Washington Townships) and SHELBY COUNTIES

	Rates	Fringes
Bricklayer, Stonemason.....	\$ 31.40	18.55

BROH0032-001 06/01/2022

GALLIA & MEIGS

	Rates	Fringes
Bricklayer, Stonemason.....	\$ 31.40	18.55

BROH0035-002 06/01/2022

ALLEN, AUGLAIZE, MERCER and VAN WERT COUNTIES

	Rates	Fringes
Bricklayer, Stonemason.....	\$ 31.40	18.55

BROH0039-002 06/01/2022

ADAMS & SCIOTO

	Rates	Fringes
Bricklayer, Stonemason.....	\$ 31.40	18.55

BROH0040-003 06/01/2022

ASHLAND, CRAWFORD, HARDIN, HOLMES, MARION, MORROW, RICHLAND, WAYNE and WYANDOT (Except Crawford, Ridge, Richland & Tymochtee Townships) COUNTIES

Rates Fringes

Bricklayer, Stonemason.....\$ 32.49 23.43

FOOTNOTE: Layout Man and Sawman rate: \$1.00 per hour above journeyman rate. Free standing stack work ground level to top of stack; Sandblasting and laying of carbon masonry material in swing stage and/or scaffold; Ramming and spading of plastics and gunniting: \$1.50 per hour above journeyman rate. ""Hot"" work: \$2.50 above journeyman rate.

BROH0044-002 06/01/2022

Rates Fringes

Bricklayer, Stonemason
COSHOCKTON, FAIRFIELD,
GUERNSEY, HOCKING, KNOX,
KICKING, MORGAN,
MUSKINGUM, NOBLE (Beaver,
Buffalo, Seneca & Wayne
Townships) & PERRY
COUNTIES:.....\$ 31.40 18.55

BROH0045-002 06/01/2021

FAYETTE, JACKSON, PIKE, ROSS and VINTON COUNTIES

Rates Fringes

Bricklayer, Stonemason.....\$ 30.40 17.66

BROH0046-002 06/01/2022

ERIE, HANCOCK, HURON, OTTAWA, SANDUSKY, SENECA, WOOD (Perry & Bloom Townships) and WYANDOT (Tymochtee, Crawford, Ridge & Richland Townships) COUNTIES & the Islands of Lake Erie north of Sandusky

Rates Fringes

Bricklayer, Stonemason.....\$ 31.40 18.55

FOOTNOTE: Layout Man and Sawman rate: \$1.00 per hour above journeyman rate. Free standing stack work ground level to top of stack; Sandblasting and laying of carbon masonry material in swing stage and/or scaffold; Ramming and spading of plastics and gunniting: \$1.50 per hour above journeyman rate. ""Hot"" work: \$2.50 above journeyman rate.

BROH0052-001 06/01/2022

ATHENS COUNTY

Rates Fringes

Bricklayer, Stonemason.....\$ 31.40 18.55

BROH0052-003 06/01/2022

NOBLE (Brookfield, Noble, Center, Sharon, Olive, Enoch, Stock,

Jackson, Jefferson & Elk Townships) and WASHINGTON COUNTIES

	Rates	Fringes
Bricklayer, Stonemason.....	\$ 31.40	18.55

 BROH0055-003 06/01/2022

DELAWARE, FRANKLIN, MADISON, PICKAWAY and UNION COUNTIES

	Rates	Fringes
Bricklayer, Stonemason.....	\$ 31.40	18.55

 CARP0003-004 05/01/2017

MAHONING & TRUMBULL

	Rates	Fringes
CARPENTER.....	\$ 26.20	17.42

 CARP0069-003 05/01/2017

CARROLL, STARK, TUSCARAWAS & WAYNE

	Rates	Fringes
CARPENTER.....	\$ 25.98	15.98

 CARP0069-006 05/01/2017

COSHOCTON, HOLMES, KNOX & MORROW

	Rates	Fringes
CARPENTER.....	\$ 24.04	15.29

 CARP0171-002 05/01/2019

BELMONT, COLUMBIANA, HARRISON, JEFFERSON & MONROE

	Rates	Fringes
CARPENTER.....	\$ 27.37	20.02

 CARP0200-002 05/01/2021

ADAMS, ATHENS, DELAWARE, FAIRFIELD, FAYETTE, FRANKLIN, GALLIA, GUERNSEY, HIGHLAND, HOCKING, JACKSON, LAWRENCE, LICKING, MADISON, MARION, MEIGS, MORGAN, MUSKINGUM, NOBLE, PERRY, PICKAWAY, PIKE, ROSS, SCIOTO, UNION, VINTON and WASHINGTON COUNTIES

	Rates	Fringes
CARPENTER.....	\$ 30.28	20.08
Diver.....	\$ 39.41	10.40
PILEDRIVERMAN.....	\$ 30.28	20.08

 CARP0248-005 07/01/2008

LUCAS & WOOD

	Rates	Fringes
CARPENTER.....	\$ 27.27	14.58

 CARP0248-008 07/01/2008

	Rates	Fringes
CARPENTER DEFIANCE, FULTON, HANCOCK, HENRY, PAULDING & WILLIAMS COUNTIES.....	\$ 23.71	13.28

 CARP0254-002 05/01/2017

ASHTABULA, CUYAHOGA, GEAUGA & LAKE

	Rates	Fringes
CARPENTER.....	\$ 32.40	16.97

 CARP0372-002 05/01/2016

ALLEN, AUGLAIZE, HARDIN, MERCER, PUTNAM & VAN WERT

	Rates	Fringes
CARPENTER.....	\$ 24.54	18.21

 CARP0639-003 05/01/2017

MEDINA, PORTAGE & SUMMIT

	Rates	Fringes
CARPENTER.....	\$ 30.42	16.99

 CARP0735-002 05/01/2019

ASHLAND, ERIE, HURON, LORAIN & RICHLAND

	Rates	Fringes
CARPENTER.....	\$ 26.30	17.91

 CARP1311-001 05/01/2017

BROWN, BUTLER, CHAMPAIGN, CLARK, CLERMONT, CLINTON, DARKE,
 GREENE, HAMILTON, LOGAN, MIAMI, MONTGOMERY, PREBLE, SHELBY &
 WARREN

	Rates	Fringes
Carpenter & Piledrivermen.....	\$ 29.34	15.95
Diver.....	\$ 40.58	9.69

 CARP1393-002 07/01/2008

CRAWFORD, DEFIANCE, FULTON, HANCOCK, HENRY, LUCAS, OTTAWA,
 PAULDING, SANDUSKY, SENECA, WILLIAMS & WOOD

Rates Fringes

Piledrivermen & Diver's Tender...\$ 27.30 16.05

DIVERS - \$250.00 per day

CARP1393-003 07/01/2008

ALLEN, AUGLAIZE, HARDIN, MERCER, PUTNAM, VAN WERT & WYANDOT

Rates Fringes

Piledrivermen & Diver's Tender...\$ 25.15 15.92

DIVERS - \$250.00 per day

CARP1871-006 05/01/2017

BELMONT, HARRISON, & MONROE

Rates Fringes

Diver, Wet.....\$ 48.11 17.33

Piledrivermen; Diver, Dry.....\$ 32.07 17.33

CARP1871-008 05/01/2017

ASHLAND, ASHTABULA, CUYAHOGA, ERIE, GEAUGA, HURON, LAKE,
LORAIN, MEDINA, PORTAGE, RICHLAND & SUMMIT

Rates Fringes

Diver, Wet.....\$ 45.80 18.84

Piledrivermen; Diver, Dry.....\$ 30.53 18.84

CARP1871-014 05/01/2017

CARROLL, STARK, TUSCARAWAS & WAYNE

Rates Fringes

Diver, Wet.....\$ 38.34 16.95

Piledrivermen; Diver, Dry.....\$ 25.56 16.95

CARP1871-015 05/01/2017

COSHOCTON, HOLMES, KNOX & MORROW

Rates Fringes

Diver, Wet.....\$ 37.34 16.07

Piledrivermen; Diver, Dry.....\$ 24.89 16.07

CARP1871-017 05/01/2017

MAHONING & TRUMBULL

Rates Fringes

Diver, Wet.....\$ 40.65 17.62

Piledrivermen; Diver, Dry.....\$ 27.10 17.62

CARP2235-012 01/01/2014

COLUMBIANA & JEFFERSON

	Rates	Fringes
PILEDRIVERMAN.....	\$ 31.74	16.41

 CARP2239-001 07/01/2008

CRAWFORD, OTTAWA, SANDUSKY, SENECA & WYANDOT

	Rates	Fringes
CARPENTER.....	\$ 23.71	13.28

 ELEC0008-002 05/23/2022

DEFIANCE, FULTON, HANCOCK, HENRY, LUCAS, OTTAWA, PAULDING,
 PUTNAM, SANDUSKY, SENECA, WILLIAMS & WOOD

	Rates	Fringes
CABLE SPLICER.....	\$ 38.98	18.96
ELECTRICIAN.....	\$ 44.79	4.5%+21.61

 ELEC0032-003 12/05/2022

ALLEN, AUGLAIZE, HARDIN, LOGAN, MERCER, SHELBY, VAN WERT &
 WYANDOT (Crawford, Jackson, Marseilles, Mifflin, Ridgeland,
 Ridge & Salem Townships)

	Rates	Fringes
ELECTRICIAN.....	\$ 34.67	21.48

 * ELEC0038-002 04/24/2023

CUYAHOGA, GEAUGA (Bainbridge, Chester & Russell Townships) &
 LORAIN (Columbia Township)

	Rates	Fringes
ELECTRICIAN Excluding Sound & Communications Work.....	\$ 43.13	23.31

FOOTNOTES;

- a. 6 Paid Holidays: New Year's Day; Memorial Day; July 4th;
 Labor Day; Thanksgiving Day; & Christmas Day
- b. 1 week's paid vacation for 1 year's service; 2 weeks' paid
 vacation for 2 or more years' service

 * ELEC0038-008 04/24/2023

CUYAHOGA, GEAUGA (Bainbridge, Chester & Russell Townships) &
 LORAIN (Columbia Township)

	Rates	Fringes
Sound & Communication Technician Communications Technician...	\$ 29.80	13.80

Installer Technician.....\$ 28.55

13.76

FOOTNOTES;

- a. 6 Paid Holidays: New Year's Day; Memorial Day; July 4th; Labor Day; Thanksgiving Day; & Christmas Day
- b. 1 week's paid vacation for 1 year's service; 2 weeks' paid vacation for 2 or more years' service

ELEC0064-003 11/28/2022

COLUMBIANA (Butler, Fairfield, Perry, Salem & Unity Townships)
MAHONING (Austintown, Beaver, Berlin, Boardman, Canfield, Ellsworth, Coitsville, Goshen, Green, Jackson, Poland, Springfield & Youngstown Townships), & TRUMBULL (Hubbard & Liberty Townships)

	Rates	Fringes
ELECTRICIAN.....	\$ 36.10	18.91

ELEC0071-001 01/01/2019

ASHLAND, CHAMPAIGN, CLARK, COSHOCTON, CRAWFORD, DELAWARE, FAIRFIELD, FAYETTE, FRANKLIN, GUERNSEY, HIGHLAND, HOCKING, JACKSON (Coal, Jackson, Liberty, Milton, Washington & Wellston Townships), KNOX, LICKING, MADISON, MARION, MONROE, MORGAN, MORROW, MUSKINGUM, NOBLE, PERRY, PICKAWAY, PIKE (Beaver, Benton, Jackson, Mifflin, Pebble, Peepee, Perry & Seal Townships), RICHLAND, ROSS, TUSCARAWAS (Auburn, Bucks, Clay, Jefferson, Oxford, Perry, Salem, Rush, Washington & York Townships), UNION, VINTON (Clinton, Eagle, Elk, Harrison, Jackson, Richland & Swan Townships), and WASHINGTON COUNTIES

	Rates	Fringes
Line Construction		
Equipment Operators.....	\$ 33.62	13.40
Groundmen.....	\$ 24.17	11.32
Linemen & Cable Splicers....	\$ 38.27	14.42

ELEC0071-004 01/01/2019

AUGLAIZE, CLINTON, DARKE, GREENE, LOGAN, MERCER, MIAMI, MONTGOMERY, PREBLE, and SHELBY COUNTIES

	Rates	Fringes
Line Construction		
Equipment Operator.....	\$ 33.62	13.40
Groundman.....	\$ 24.17	11.32
Lineman & Cable Splicers....	\$ 38.27	14.42

ELEC0071-005 12/31/2018

ASHTABULA, CUYAHOGA, GEAUGA, LAKE & LORAIN

	Rates	Fringes
LINE CONSTRUCTION: Equipment Operator		
DOT/Traffic Signal &		

Highway Lighting Projects...\$ 32.44	14.10
Municipal Power/Transit Projects.....\$ 40.10	16.42
LINE CONSTRUCTION: Groundman DOT/Traffic Signal & Highway Lighting Projects...\$ 25.06	12.26
Municipal Power/Transit Projects.....\$ 31.19	14.11
LINE CONSTRUCTION: Linemen/Cable Splicer DOT/Traffic Signal & Highway Lighting Projects...\$ 36.13	15.03
Municipal Power/Transit Projects.....\$ 44.56	17.58

ELEC0071-008 01/01/2019

COLUMBIANA, MAHONING, and TRUMBULL COUNTIES

	Rates	Fringes
Line Construction		
Equipment Operator.....\$ 33.62		13.40
Groundman.....\$ 24.17		11.32
Lineman & Cable Splicers....\$ 38.27		14.42

ELEC0071-010 01/01/2019

BELMONT, CARROLL, HARRISON, HOLMES, JEFFERSON, MEDINA, PORTAGE,
STARK, SUMMIT, and WAYNE COUNTIES

	Rates	Fringes
Line Construction		
Equipment Operator.....\$ 33.62		13.40
Groundman.....\$ 24.17		11.32
Lineman & Cable Splicers....\$ 38.27		14.42

ELEC0071-013 01/01/2019

BROWN, BUTLER, CLERMONT, HAMILTON, and WARREN COUNTIES

	Rates	Fringes
Line Construction		
Equipment Operator.....\$ 33.62		13.40
Groundman.....\$ 24.17		11.32
Lineman & Cable Splicers....\$ 38.27		14.42

ELEC0071-014 01/01/2019

ADAMS, ATHENS, GALLIA, JACKSON (Bloomfield, Franklin, Hamilton,
Lick, Jefferson, Scioto & Madison Townships), LAWRENCE, MEIGS,
PIKE (Camp Creek, Marion, Newton, Scioto, Sunfish & Union
Townships), SCIOTO & VINTON (Brown, Knox, Madison, Vinton &
Wilkesville Townships)

	Rates	Fringes
Line Construction		
Equipment Operator.....\$ 33.62		13.40
Groundman.....\$ 24.17		11.32
Lineman & Cable Splicers....\$ 38.27		14.42

 ELEC0082-002 12/05/2022

CLINTON, DARKE, GREENE, MIAMI, MONTGOMERY, PREBLE & WARREN
 (Wayne, Clear Creek & Franklin Townships)

	Rates	Fringes
ELECTRICIAN.....	\$ 34.25	21.26

 * ELEC0082-006 11/28/2022

CLINTON, DARKE, GREENE, MIAMI, MONTGOMERY, PREBLE & WARREN
 (Wayne, Clear Creek & Franklin Townships)

	Rates	Fringes
Sound & Communication Technician		
Cable Puller.....	\$ 13.10 **	4.76
Installer/Technician.....	\$ 26.20	13.89

 ELEC0129-003 02/27/2023

LORAIN (Except Columbia Township) & MEDINA (Litchfield & Liverpool Townships)

	Rates	Fringes
ELECTRICIAN.....	\$ 39.30	18.30

 ELEC0129-004 02/27/2023

ERIE & HURON (Lyme, Ridgefield, Norwalk, Townsend, Wakeman,
 Sherman, Peru, Bronson, Hartland, Clarksfield, Norwich,
 Greenfield, Fairfield, Fitchville & New London Townships)

	Rates	Fringes
ELECTRICIAN.....	\$ 39.30	18.30

 ELEC0141-003 09/01/2019

BELMONT COUNTY

	Rates	Fringes
CABLE SPLICER.....	\$ 30.63	25.87
ELECTRICIAN.....	\$ 30.38	25.87

 ELEC0212-003 11/26/2018

BROWN, CLERMONT & HAMILTON

	Rates	Fringes
Sound & Communication Technician.....	\$ 24.35	10.99

 ELEC0212-005 06/06/2022

BROWN, CLERMONT, and HAMILTON COUNTIES

	Rates	Fringes
ELECTRICIAN.....	\$ 33.29	21.15

ELEC0245-001 08/29/2022

ALLEN, HARDIN, VAN WERT & WYANDOT (Crawford, Jackson, Marseilles, Mifflin, Richland, Ridge & Salem Townships)

	Rates	Fringes
Line Construction		
Equipment Operator.....	\$ 32.37	26.5%+7.25
Groundman Truck Driver.....	\$ 19.35	7.00+27.25%
Lineman.....	\$ 44.22	7.00+27.25%

FOOTNOTE: a. Half day's Paid Holiday: The last 4 hours of the workday prior to Christmas or New Year's Day

ELEC0245-003 08/29/2022

DEFIANCE, FULTON, HANCOCK, HENRY, HURON, LUCAS, OTTAWA, PAULDING, PUTNAM, SANDUSKY, SENECA, WILLIAMS, and WOOD COUNTIES

	Rates	Fringes
Line Construction		
Cable Splicer.....	\$ 50.85	7.00+27.25%
Groundman/Truck Driver.....	\$ 19.35	7.00+27.25%
Heli-arc Welding.....	\$ 40.76	7.00+27.25%
Lineman.....	\$ 44.22	7.00+27.25%
Operator - Class 1.....	\$ 35.38	7.00+27.25%
Operator - Class 2.....	\$ 28.32	7.00+27.25%
Traffic Signal & Lighting Technician.....	\$ 39.80	7.00+27.25%

FOOTNOTE: a. 6 Observed Holidays: New Year's Day; Memorial Day; Independence Day; Labor Day; Thanksgiving Day; & Christmas Day. Employees who work on a holiday shall be paid at a rate of double their applicable classified straight-time rates for the work performed on such holiday.

ELEC0245-004 08/29/2022

ERIE COUNTY

	Rates	Fringes
Line Construction		
Cable Splicer.....	\$ 49.14	26.75%+6.75
Cablesplicer.....	\$ 50.85	7.00+27.25%
Groundman/Truck Driver.....	\$ 19.35	7.00+27.25%
Lineman.....	\$ 44.22	7.00+27.25%
Operator - Class 1.....	\$ 35.38	7.00+27.25%
Operator - Class 2.....	\$ 28.32	7.00+27.25%

FOOTNOTE: a. 6 Observed Holidays: New Year's Day; Memorial Day; Independence Day; Labor Day; Thanksgiving Day; & Christmas Day. Employees who work on a holiday shall be

paid at a rate of double their applicable classified straight-time rates for the work performed on such holiday.

ELEC0246-001 10/31/2022

	Rates	Fringes
ELECTRICIAN.....	\$ 40.50	84%+36.47

FOOTNOTE: a. 1 1/2 Paid Holidays: The last scheduled workday prior to Christmas & 4 hours on Good Friday.

ELEC0306-005 05/28/2018

MEDINA (Brunswick, Chatham, Granger, Guilford, Harrisville, Hinckley, Homer, Lafayette, Medina, Montville, Sharon, Spencer, Wadsworth, Westfield & York Townships), PORTAGE (Atwater, Aurora, Brimfield, Deerfield, Franklin, Mantua, Randolph, Ravenna, Rootstown, Shalersville, Streetsboro & Suffield Townships), SUMMIT & WAYNE (Baughman, Canaan, Chester, Chippewa, Congress, Green, Milton, & Wayne Townships)

	Rates	Fringes
CABLE SPLICER.....	\$ 36.87	16.56
ELECTRICIAN.....	\$ 34.54	5%+18.06

ELEC0317-002 05/30/2022

GALLIA & LAWRENCE

	Rates	Fringes
CABLE SPLICER.....	\$ 32.68	18.13
ELECTRICIAN.....	\$ 35.85	28.25

ELEC0540-005 12/26/2022

CARROLL (Northern half, including Fox, Harrison, Rose & Washington Townships), COLUMBIANA (Knox Township), HOLMES, MAHONING (Smith Township), STARK, TUSCARAWAS (North of Auburn, Clay, Rush & York Townships), and WAYNE (South of Baughman, Chester, Green & Wayne Townships) COUNTIES

	Rates	Fringes
ELECTRICIAN.....	\$ 36.28	27.04

ELEC0573-003 11/28/2022

ASHTABULA (Colebrook, Wayne, Williamsfield, Orwell & Windsor Townships), GEAUGA (Auburn, Middlefield, Parkman & Troy Townships), MAHONING (Milton Township), PORTAGE (Charlestown, Edinburg, Freedom, Hiram, Nelson, Palmyra, Paris & Windham Townships), and TRUMBULL (Except Liberty & Hubbard Townships)

	Rates	Fringes
ELECTRICIAN.....	\$ 38.70	20.94

ELEC0575-001 11/21/2022

ADAMS, FAYETTE, HIGHLAND, HOCKING, JACKSON (Bloomfield, Franklin, Hamilton, Jefferson, Lick, Madison, Scioto, Coal, Jackson, Liberty, Milton & Washington Townships), PICKAWAY (Deer Creek, Perry, Pickaway, Salt Creek & Wayne Townships), PIKE (Beaver, Benton, Jackson, Mifflin, Pebble, PeePee, Perry, Seal, Camp Creek, Newton, Scioto, Sunfish, Union & Marion Townships), ROSS, SCIOTO & VINTON (Clinton, Eagle, Elk, Harrison, Jackson, Richland & Swan Townships)

	Rates	Fringes
ELECTRICIAN.....	\$ 36.00	21.14

ELEC0648-001 08/29/2022

BUTLER and WARREN COUNTIES (Deerfield, Hamilton, Harlan, Massie, Salem, Turtle Creek, Union & Washington Townships)

	Rates	Fringes
CABLE SPLICER.....	\$ 30.50	18.23
ELECTRICIAN.....	\$ 33.00	21.44

ELEC0673-004 01/01/2023

ASHTABULA (Excluding Orwell, Colebrook, Williamsfield, Wayne & Windsor Townships), GEAUGA (Burton, Chardon, Claridon, Hambden, Huntsburg, Montville, Munson, Newbury & Thompson Townships) and LAKE COUNTIES

	Rates	Fringes
CABLE SPLICER.....	\$ 33.81	21.47
ELECTRICIAN.....	\$ 35.15	23.41

ELEC0683-002 05/30/2022

CHAMPAIGN, CLARK, DELAWARE, FAIRFIELD, FRANKLIN, MADISON, PICKAWAY (Circleville, Darby, Harrison, Jackson, Madison, Monroe, Muhlenberg, Scioto, Walnut & Washington Townships), and UNION COUNTIES

	Rates	Fringes
CABLE SPLICER.....	\$ 37.50	23.15
ELECTRICIAN.....	\$ 36.50	23.15

ELEC0688-003 05/30/2022

ASHLAND, CRAWFORD, HURON (Richmond, New Haven, Ripley & Greenwich Townships), KNOX (Liberty, Clinton, Union, Howard, Monroe, Middleberry, Morris, Wayne, Berlin, Pike, Brown & Jefferson Townships), MARION, MORROW, RICHLAND and WYANDOT (Sycamore, Crane, Eden, Pitt, Antrim & Tymochtee Townships) COUNTIES

Rates Fringes

ELECTRICIAN.....\$ 32.30 21.83

ELEC0972-002 06/01/2021

ATHENS, MEIGS, MONROE, MORGAN, NOBLE, VINTON (Brown, Knox, Madison, Vinton & Wilkesville Townships), and WASHINGTON COUNITES

Rates Fringes

CABLE SPLICER.....\$ 37.35 27.81
ELECTRICIAN.....\$ 34.30 27.62

ELEC1105-001 05/29/2023

COSHOCTON, GUERNSEY, KNOX (Jackson, Clay, Morgan, Miller, Milford, Hilliar, Butler, Harrison, Pleasant & College Townships), LICKING, MUSKINGUM, PERRY, and TUSCARAWAS (Auburn, York, Clay, Jefferson, Rush, Oxford, Washington, Salem, Perry & Bucks Townships) COUNTIES

Rates Fringes

ELECTRICIAN.....\$ 36.45 24.22

ENGI0018-003 05/01/2019

ASHTABULA, CUYAHOGA, ERIE, GEauga, LAKE, LORAIN, MEDINA, PORTAGE, and SUMMIT COUNTIES

Rates Fringes

POWER EQUIPMENT OPERATOR

GROUP 1.....\$ 38.63 15.20
GROUP 2.....\$ 38.53 15.20
GROUP 3.....\$ 37.49 15.20
GROUP 4.....\$ 36.27 15.20
GROUP 5.....\$ 30.98 15.20
GROUP 6.....\$ 38.88 15.20
GROUP 7.....\$ 39.13 15.20

OPERATING ENGINEER CLASSIFICATIONS

GROUP 1 - Air Compressor on Steel Erection; Barrier Moving Machine; Boiler Operator on Compressor or Generator when mounted on a Rig; Cableway; Combination Concrete Mixer & Tower; Concrete Plant (over 4 yd. Capacity); Concrete Pump; Crane (All Types, Including Boom Truck, Cherry Picker); Crane-Compact, Track or Rubber over 4,000 lbs. capacity; Cranes-Self Erecting, Stationary, Track or Truck (All Configurations); Derrick; Dragline; Dredge (Dipper, Clam or Suction); Elevating Grader or Euclid Loader; Floating Equipment (All Types); Gradall; Helicopter Crew (Operator-Hoist or Winch); Hoe (all types); Hoisting Engine on Shaft or Tunnel Work; Hydraulic Gantry (Lifting System); Industrial-Type Tractor; Jet Engine Dryer (D8 or D9) Diesel Tractor; Locomotive (Standard Gauge); Maintenance Operator Class A; Mixer, Paving (Single or Double Drum); Mucking Machine; Multiple Scraper; Piledriving Machine (All Types); Power Shovel; Prentice Loader; Quad 9 (Double Pusher); Rail Tamper (with auto lifting & aligning device); Refrigerating Machine (Freezer Operation); Rotary Drill, on Caisson work;

Rough Terrain Fork Lift with Winch/Hoist; Side-Boom; Slip-Form Paver; Tower Derrick; Tree Shredder; Trench Machine (Over 24" wide); Truck Mounted Concrete Pump; Tug Boat; Tunnel Machine and/or Mining Machine; Wheel Excavator; and Asphalt Plant Engineer (Cleveland District Only).

GROUP 2 – Asphalt Paver; Automatic Subgrader Machine, Self-Propelled (CMI Type); Bobcat Type and/or Skid Steer Loader with Hoe Attachment Greater than 7,000 lbs.; Boring Machine More than 48"; Bulldozer; Endloader; Horizontal Directional Drill (Over 50,000 ft lbs thrust); Hydro Milling Machine; Kolman-type Loader (production type-Dirt); Lead Greaseman; Lighting & Traffic Signal Installation Equipment (includes all groups or classifications); Material Transfer Equipment (Shuttle Buggy) Asphalt; Pettibone-Rail Equipment; Power Grader; Power Scraper; Push Cat; Rotomill (all), Grinders & Planers of All types; Trench Machine (24" wide & under); Vermeer type Concrete Saw; and Maintenance Operators (Portage and Summit Counties Only).

GROUP 3 – A-Frame; Air Compressor on Tunnel Work (low pressure); Asphalt Plant Engineer (Portage and Summit Counties Only); Bobcat-type and/or Skid Steer Loader with or without Attachments; Highway Drills (all types); Locomotive (narrow gauge); Material Hoist/Elevator; Mixer, Concrete (more than one bag capacity); Mixer, one bag capacity (Side Loader); Power Boiler (Over 15 lbs. Pressure) Pump Operator installing & operating Well Points; Pump (4" & over discharge); Roller, Asphalt; Rotovator (lime soil stabilizer); Switch & Tie Tampers (without lifting & aligning device); Utility Operator (Small equipment); Welding Machines; and Railroad Tie Inserter/Remover; Articulating/straight bed end dumps if assigned (minus \$4.00 per hour).

GROUP 4 – Backfiller; Ballast Re-locator; Bars, Joint & Mesh Installing Machine; Batch Plant; Boring Machine Operator (48" or less); Bull Floats; Burlap & Curing Machine; Concrete Plant (capacity 4 yd. & under); Concrete Saw (Multiple); Conveyor (Highway); Crusher; Deckhand; Farm-type Tractor with attachments (highway); Finishing Machine; Fireperson, Floating Equipment (all types); Forklift; Form Trencher; Hydro Hammer expect masonry; Hydro Seeder; Pavement Breaker; Plant Mixer; Post Driver; Post Hole Digger (Power Auger); Power Brush Burner; Power Form Handling Equipment; Road Widening Trencher; Roller (Brick, Grade & Macadam); Self-Propelled Power Spreader; Self-Propelled Power Subgrader; Steam Fireperson; Tractor (Pulling Sheepfoot, Roller or Grader); and Vibratory Compactor with Integral Power.

GROUP 5 – Compressor (Portable, Sewer, Heavy & Highway); Drum Fireperson (Asphalt Plant); Generator; Masonry Fork Lift; Inboard-Outboard Motor Boat Launch; Oil Heater (asphalt plant); Oiler/Helper; Power Driven Heater; Power Sweeper & Scrubber; Pump (under 4" discharge); Signaller; Tire Repairperson; VAC/ALLS; Cranes – Compact, track or rubber under 4,000 pound capacity; fueling and greasing; and Chainmen.

GROUP 6 – Master Mechanic & Boom from 150 to 180.

GROUP 7 – Boom from 180 and over.

 ENGI0018-004 05/01/2019

ADAMS, ALLEN, ASHLAND, ATHENS, AUGLAIZE, BELMONT, BROWN, BUTLER, CARROLL, CHAMPAIGN, CLARK, CLERMONT, CLINTON, COSHOCTON, CRAWFORD, DARKE, DEFIANCE, DELAWARE, FAIRFIELD, FAYETTE, FRANKLIN, FULTON, GALLIA, GREENE, GUERNSEY, HAMILTON, HANCOCK, HARDIN, HARRISON, HENRY, HIGHLAND, HOCKING, HOLMES, HURON, JACKSON, JEFFERSON, KNOX, LAWRENCE, LICKING, LOGAN, LUCAS, MADISON, MARION, MEIGS, MERCER, MIAMI, MONROE, MONTGOMERY, MORGAN, MORROW, MUSKINGUM, NOBLE, OTTAWA, PAULDING, PERRY, PICKAWAY, PIKE, PREBLE, PUTNAM, RICHLAND, ROSS, SANDUSKY, SCIOTO, SENECA, SHELBY, STARK, TUSCARAWAS, UNION, VAN WERT, VINTON, WARREN, WASHINGTON, WAYNE, WILLIAMS, WOOD, and YANDOT COUNTIES

	Rates	Fringes
POWER EQUIPMENT OPERATOR		
GROUP 1.....	\$ 37.14	15.20
GROUP 2.....	\$ 37.02	15.20
GROUP 3.....	\$ 35.98	15.20
GROUP 4.....	\$ 34.80	15.20
GROUP 5.....	\$ 29.34	15.20
GROUP 6.....	\$ 37.39	15.20
GROUP 7.....	\$ 37.64	15.20

OPERATING ENGINEER CLASSIFICATIONS

GROUP 1 – Air Compressor on Steel Erection; Barrier Moving Machine; Boiler Operator on Compressor or Generator when mounted on a Rig; Cableway; Combination Concrete Mixer & Tower; Concrete Plant (over 4 yd. Capacity); Concrete Pump; Crane (All Types, Including Boom Truck, Cherry Picker); Crane-Compact, Track or Rubber over 4,000 lbs. capacity; Cranes-Self Erecting, Stationary, Track or Truck (All Configurations); Derrick; Dragline; Dredge (Dipper, Clam or Suction); Elevating Grader or Euclid Loader; Floating Equipment (All Types); Gradall; Helicopter Crew (Operator-Hoist or Winch); Hoe (all types); Hoisting Engine on Shaft or Tunnel Work; Hydraulic Gantry (Lifting System); Industrial-Type Tractor; Jet Engine Dryer (D8 or D9) Diesel Tractor; Locomotive (Standard Gauge); Maintenance Operator Class A; Mixer, Paving (Single or Double Drum); Mucking Machine; Multiple Scraper; Piledriving Machine (All Types); Power Shovel; Prentice Loader; Quad 9 (Double Pusher); Rail Tamper (with auto lifting & aligning device); Refrigerating Machine (Freezer Operation); Rotary Drill, on Caisson work; Rough Terrain Fork Lift with Winch/Hoist; Side-Boom; Slip-Form Paver; Tower Derrick; Tree Shredder; Trench Machine (Over 24" wide); Truck Mounted Concrete Pump; Tug Boat; Tunnel Machine and/or Mining Machine; and Wheel Excavator.

GROUP 2 – Asphalt Paver; Automatic Subgrader Machine, Self-Propelled (CMI Type); Bobcat Type and/or Skid Steer Loader with Hoe Attachment Greater than 7,000 lbs.; Boring Machine More than 48"; Bulldozer; Endloader; Hydro Milling Machine; Horizontal Directional Drill (over 50,000 ft. lbs. thrust); Kolman-type Loader (production type-Dirt); Lead Greaseman; Lighting & Traffic Signal Installation Equipment (includes all groups or classifications); Material Transfer Equipment (Shuttle Buggy) Asphalt; Pettibone-Rail

Equipment; Power Grader; Power Scraper; Push Cat; Rotomill (all), Grinders & Planers of All types; Trench Machine (24''' wide & under); and Vermeer type Concrete Saw.

GROUP 3 – A-Frame; Air Compressor on Tunnel Work (low pressure); Asphalt Plant Engineer; Bobcat-type and/or Skid Steer Loader with or without Attachments; Highway Drills (all types); Locomotive (narrow gauge); Material Hoist/Elevator; Mixer, Concrete (more than one bag capacity); Mixer, one bag capacity (Side Loader); Power Boiler (Over 15 lbs. Pressure) Pump Operator installing & operating Well Points; Pump (4''' & over discharge); Railroad Tie Inserter/Remover; Roller, Asphalt; Rotovator (lime soil stabilizer); Switch & Tie Tampers (without lifting & aligning device); Utility Operator (Small equipment); and Welding Machines; Artiaculating/straight bed end dumps if assigned (minus \$4.00 per hour.

GROUP 4 – Backfiller; Ballast Re-locator; Bars, Joint & Mesh Installing Machine; Batch Plant; Boring Machine Operator (48''' or less); Bull Floats; Burlap & Curing Machine; Concrete Plant (capacity 4 yd. & under); Concrete Saw (Multiple); Conveyor (Highway); Crusher; Deckhand; Farm-type Tractor with attachments (highway); Finishing Machine; Fireperson, Floating Equipment (all types); Fork Lift; Form Trencher; Hydro Hammer expect masonry; Hydro Seeder; Pavement Breaker; Plant Mixer; Post Driver; Post Hole Digger (Power Auger); Power Brush Burner; Power Form Handling Equipment; Road Widening Trencher; Roller (Brick, Grade & Macadam); Self-Propelled Power Spreader; Self-Propelled Power Subgrader; Steam Fireperson; Tractor (Pulling Sheepfoot, Roller or Grader); and Vibratory Compactor with Integral Power.

GROUP 5 – Compressor (Portable, Sewer, Heavy & Highway); Drum Fireperson (Asphalt Plant); Generator; Masonary Forklift; Inboard-Outboard Motor Boat Launch; Oil Heater (asphalt plant); Oiler/Helper; Power Driven Heater; Power Sweeper & Scrubber; Pump (under 4''' discharge); Signalperson; Tire Repairperson; VAC/ALLS; Cranes – Compact, track or rubber under 4,000 pound capacity; fueling and greasing; and Chainmen.

GROUP 6 – Master Mechanic & Boom from 150 to 180.

GROUP 7 – Boom from 180 and over.

ENGI0066-023 06/01/2017

COLUMBIANA, MAHONING & TRUMBULL COUNTIES

	Rates	Fringes
POWER EQUIPMENT OPERATOR		
ASBESTOS; HAZARDOUS/TOXIC WASTE PROJECTS		
GROUP 1 – A & B.....	\$ 39.23	19.66
ASBESTOS; HAZARDOUS/TOXIC WASTE PROJECTS		
GROUP 2 – A & B.....	\$ 38.90	19.66
ASBESTOS; HAZARDOUS/TOXIC WASTE PROJECTS		
GROUP 3 – A & B.....	\$ 34.64	19.66
ASBESTOS; HAZARDOUS/TOXIC		

WASTE PROJECTS	
GROUP 4 – A & B.....\$ 30.70	19.66
ASBESTOS; HAZARDOUS/TOXIC	
WASTE PROJECTS	
GROUP 5 – A & B.....\$ 27.30	19.66
HAZARDOUS/TOXIC WASTE	
PROJECTS	
GROUP 1 – C & D.....\$ 35.96	19.66
HAZARDOUS/TOXIC WASTE	
PROJECTS	
GROUP 2 – C & D.....\$ 35.66	19.66
HAZARDOUS/TOXIC WASTE	
PROJECTS	
GROUP 3 – C & D.....\$ 31.76	19.66
HAZARDOUS/TOXIC WASTE	
PROJECTS	
GROUP 4 – C & D.....\$ 28.14	19.66
HAZARDOUS/TOXIC WASTE	
PROJECTS	
GROUP 5 – C & D.....\$ 25.03	19.66
ALL OTHER WORK	
GROUP 1.....\$ 32.69	19.66
ALL OTHER WORK	
GROUP 2.....\$ 32.42	19.66
ALL OTHER WORK	
GROUP 3.....\$ 28.87	19.66
ALL OTHER WORK	
GROUP 4.....\$ 25.58	19.66
ALL OTHER WORK	
GROUP 5.....\$ 22.75	19.66

GROUP 1 – Rig, Pile Driver or Caisson Type; & Rig, Pile Hydraulic Unit Attached

GROUP 2 – Asphalt Heater Planer; Backfiller with Drag Attachment; Backhoe; Backhoe with Shear attached; Backhoe-Rear Pivotal Swing; Batch Plant-Central Mix Concrete; Batch Plant, Portable concrete; Berm Builder-Automatic; Boat Derrick; Boat-Tug; Boring Machine Attached to Tractor; Bullclam; Bulldozer; C.M.I. Road Builder & Similar Type; Cable Placer & Layer; Carrier-Straddle; Carryall-Scraper or Scoop; Chicago Boom; Compactor with Blade Attached; Concrete Saw (Vermeer or similar type); Concrete Spreader Finisher; Combination, Bidwell Machine; Crane; Crane-Electric Overhead; Crane-Rough Terrain; Crane-Side Boom; Crane-Truck; Crane-Tower; Derrick-Boom; Derrick-Car; Digger-Wheel (Not trencher or road widener); Double Nine; Drag Line; Dredge; Drill-Kenny or Similar Type; Easy Pour Median Barrier Machine (or similar type); Electromatic; Frankie Pile; Gradall; Grader; Gurry; Self-Propelled; Heavy Equipment Robotics Operator/Mechanic; Hoist-Monorail; Hoist-Stationary & Mobile Tractor; Hoist, 2 or 3 drum; Horizontal Directional Drill Operator; Jackall; Jumbo Machine; Kocal & Kuhlman; Land-Seagoing Vehicle; Loader, Elevating; Loader, Front End; Loader, Skid Steer; Locomotive; Mechanic/Welder; Metro Chip Harvester with Boom; Mucking Machine; Paver-Asphalt Finishing Machine; Paver-Road Concrete; Paver-Slip Form (C.M.I. or similar); Place Crete Machine with Boom; Post Driver (Carrier mounted); Power Driven Hydraulic Pump & Jack (When used in Slip Form or Lift Slab Construction); Pump Crete Machine; Regulator-Ballast; Hydraulic Power Unit not attached to Rig for Pile Drillings; Rigs-Drilling; Roto Mill or similar Full Lane (8' Wide & Over); Roto Mill or similar type

(Under 8'); Shovel; Slip Form Curb Machine; Speedwing; Spikemaster; Stonecrusher; Tie Puller & Loader; Tie Tamper; Tractor-Double Boom; Tractor with Attachments; Truck-Boom; Truck-Tire; Trench Machine; Tunnel Machine (Mark 21 Java or similar); & Whirley (or similar type)

GROUP 3 - Asphalt Plant; Bending Machine (Pipeline or similar type); Boring machine, Motor Driven; Chip Harvester without Boom; Cleaning Machine, Pipeline Type; Coating Machine, Pipeline Type; Compactor; Concrete Belt Placer; Concrete Finisher; Concrete Planer or Asphalt; Concrete Spreader; Elevator; Fork Lift (Home building only); Fork lift & Lulls; Fork Lift Walk Behind (Hoisting over 1 buck high); Form Line Machine; Grease Truck operator; Grout Pump; Gunnite Machine; Horizontal Directional Drill Locator; Single Drum Hoist with or without Tower; Huck Bolting Machine; Hydraulic Scaffold (Hoisting building materials); Paving Breaker (Self-propelled or Ridden); Pipe Dream; Pot Fireperson (Power Agitated); Refrigeration Plant; Road Widener; Roller; Sasgen Derrick; Seeding Machine; Soil Stabilizer (Pump type); Spray Cure Machine, Self-Propelled; Straw Blower Machine; Sub-Grader; Tube Finisher or Broom C.M.I. or similar type; & Tugger Hoist

GROUP 4 - Air Curtain Destructor & Similar Type; Batch Plant-Job Related; Boiler Operator; Compressor; Conveyor; Curb Builder, self-propelled; Drill Wagon; Generator Set; Generator-Steam; Heater-Portable Power; Hydraulic Manipulator Crane; Jack-Hydraulic Power driven; Jack-Hydraulic (Railroad); Ladavator; Minor Machine Operator; Mixer-Concrete; Mulching Machine; Pin Puller; Power Broom; Pulverizer; Pump; Road Finishing Machine (Pull Type); Saw-Concrete-Self-Propelled (Highway Work); Signal Person; Spray Cure Machine-Motor Powered; Stump Cutter; Tractor; Trencher Form; Water Blaster; Steam Jenny; Syphon; Vibrator-Gasoline; & Welding Machine

GROUP 5 - Brakeperson; Fireperson; & Oiler

IRON0017-002 05/01/2023

ASHTABULA (North of Route 6, starting at the Geauga County Line, proceeding east to State Route 45), CUYAHOGA, ERIE (Eastern 2/3), GEAUGA, HURON (East of a line drawn from the north border through Monroeville & Willard), LAKE, LORAIN, MEDINA (North of Old Rte. #224), PORTAGE (West of a line from Middlefield to Shalersville to Deerfield), and SUMMIT (North of Old Rte. #224, including city limits of Barberton) COUNTIES

	Rates	Fringes
IRONWORKER		
Ornamental, Reinforcing, & Structural.....	\$ 35.83	28.01

IRON0017-010 05/01/2023

ASHTABULA (Eastern part from Lake Erie on the north to route #322 on the south to include Conneaut, Kingsville, Sheffield, Denmark, Dorset, Cherry Valley, Wayne, Monroe, Pierpont, Richmond, Andover & Williamsfield Townships)

Rates

Fringes

IRONWORKER

Structural, including metal building erection & Reinforcing.....	\$ 35.83	28.01
--	----------	-------

IRON0044-001 06/01/2022

ADAMS (Western Part), BROWN, BUTLER (Southern Part), CLERMONT, CLINTON (South of a line drawn from Blanchester to Lynchburg), HAMILTON, HIGHLAND (Excluding eastern one-fifth & portion of county inside lines drawn from Marshall to Lynchburg from the northern county line through E. Monroe to Marshall) and WARREN (South of a line drawn from Blanchester through Morrow to the west county line) COUNTIES

Rates

Fringes

IRONWORKER, REINFORCING.....	\$ 32.37	22.30
Beyond 30-mile radius of Hamilton County Courthouse..	\$ 28.67	21.20
Up to & including 30-mile radius of Hamilton County Courthouse.....	\$ 27.60	20.70

IRON0044-002 06/01/2023

CLINTON (South of a line drawn from Blanchester to Lynchburg), HAMILTON, HIGHLAND (Excluding eastern one-fifth & portion of county inside lines drawn from Marshall to Lynchburg from the northern county line through E. Monroe to Marshall) & WARREN (South of a line drawn from Blanchester through Morrow to the west county line)

Rates

Fringes

IRONWORKER

Fence Erector.....	\$ 30.75	23.30
Ornamental; Structural.....	\$ 32.37	23.30

IRON0055-003 07/01/2023

CRAWFORD (Area Between lines drawn from where Hwy #598 & #30 meet through N. Liberty to the northern border & from said Hwy junction point due west to the border), DEFIANCE (S. of a line drawn from where Rte. #66 meets the northern line through Independence to the eastern county border), ERIE (Western 1/3), FULTON, HANCOCK, HARDIN (North of a line drawn from Maysville to a point 4 miles south of the northern line on the eastern line), HENRY, HURON (West of a line drawn from the northern border through Monroeville & Willard), LUCAS, OTTAWA, PUTNAM (East of a line drawn from the northern border down through Miller City to where #696 meets the southern border), SANDUSKY, SENECA, WILLIAMS (East of a line drawn from Pioneer through Stryker to the southern border), WOOD & WYANDOT (North of Rte. #30)

Rates

Fringes

IRONWORKER

Fence Erector.....	\$ 25.40	23.87
--------------------	----------	-------

Flat Road Mesh.....	\$ 29.77	21.30
Tunnels & Caissons Under		
Pressure.....	\$ 29.77	21.30
All Other Work.....	\$ 34.25	28.20

IRON0147-002 06/01/2023

ALLEN (Northern half), DEFIANCE (Northern part, excluding south of a line drawn from where Rte. #66 meets the northern line through Independence to the eastern county border), MERCER (Northern half), PAULDING, PUTNAM (Western part, excluding east of a line drawn from the northern border down through Miller City to where #696 meets the southern border), VAN WERT, and WILLIAMS (Western part, excluding east of a line drawn from Pioneer through Stryker to the southern border) COUNTIES

	Rates	Fringes
IRONWORKER.....	\$ 33.00	25.59

IRON0172-002 06/01/2023

CHAMPAIGN (Eastern one-third), CLARK (Eastern one-fourth), COSHOCTON (West of a line beginning at the northwestern county line going through Walhonding & Tunnel Hill to the southern county line), CRAWFORD (South of Rte. #30), DELAWARE, FAIRFIELD, FAYETTE, FRANKLIN, HARDIN (Excluding a line drawn from Roundhead to Maysville), HIGHLAND (Eastern one-fifth), HOCKING, JACKSON (Northern half), KNOX, LICKING, LOGAN (Eastern one-third), MADISON, MARION, MORROW, MUSKINGUM (West of a line starting at Adams Mill going to Adamsville & going from Adamsville through Blue Rock to the southern border), PERRY, PICKAWAY, PIKE (Northern half), ROSS, UNION, VINTON and WYANDOT (South of Rte. #30) COUNTIES

	Rates	Fringes
IRONWORKER.....	\$ 34.07	22.55

IRON0207-004 06/01/2023

ASHTABULA (Southern part starting at the Geauga County line), COLUMBIANA (E. of a line from Damascus to Highlandtown), MAHONING (N. of Old Route #224), PORTAGE (E. of a line from Middlefield to Shalersville to Deerfield) & TRUMBULL

	Rates	Fringes
IRONWORKER		
Layout; Sheeter.....	\$ 34.00	27.16
Ornamental; Reinforcing;		
Structural.....	\$ 33.00	27.16
Ornamental; Reinforcing.....	\$ 28.92	25.61

IRON0290-002 06/01/2023

ALLEN (Southern half), AUGLAIZE, BUTLER (North of a line drawn from east to the west county line going through Oxford, Darrtown & Woodsdale), CHAMPAIGN (Excluding east of a line drawn from Catawla to the point where #68 intersects the northern county line), CLARK (Western two-thirds), CLINTON (Excluding south of a linedrawn from Blanchester to

Lynchburg), DARKE, GREENE, HIGHLAND (Inside lines drawn from Marshall to Lynchburg & from the northern county line through East Monroe to Marshall), LOGAN (West of a line drawn from West Liberty to where the northern county line meets the western county line of Hardin), MERCER (Southern half), MIAMI, MONTGOMERY, PREBLE, SHELBY & WARREN (Excluding south of a line drawn from Blanchester through Morrow to the western county line) COUNTIES

	Rates	Fringes
IRONWORKER.....	\$ 32.69	24.05

IRON0549-003 12/01/2022

BELMONT, GUERNSEY, HARRISON, JEFFERSON, MONROE & MUSKINGUM (Excluding portion west of a line starting at Adams Mill going to Adamsville and going from Adamsville through Blue Rock to the south border)

	Rates	Fringes
IRONWORKER.....	\$ 35.19	25.66

IRON0550-004 05/01/2023

ASHLAND, CARROLL, COLUMBIANA (W. of a line from Damascus to Highlandtown), COSHOCTON (E. of a line beginning at NW Co. line going through Walhonding & Tunnel Hill to the South Co. line), HOLMES, HURON (S. of Old Rte. #224), MAHONING (S. of Old Rte. #224), MEDINA (S. of Old Rte. #224), PORTAGE (S. of Old Rte. #224), RICHLAND, STARK, SUMMIT (S. of Old Rte. #224, Excluding city limits of Barberton), TUSCARAWAS, & WAYNE

	Rates	Fringes
Ironworkers:Structural, Ornamental and Reinforcing.....	\$ 33.00	22.27

IRON0769-004 06/01/2023

ADAMS (Eastern Half), GALLIA, JACKSON (Southern Half), LAWRENCE & SCIOTO

	Rates	Fringes
IRONWORKER.....	\$ 36.16	28.34

IRON0787-003 06/01/2023

ATHENS, MEIGS, MORGAN, NOBLE, and WASHINGTON COUNTIES

	Rates	Fringes
IRONWORKER.....	\$ 32.30	23.95

LABO0265-008 05/01/2023

	Rates	Fringes
LABORER		

ASHTABULA, ERIE, HURON, LORAIN, LUCAS, MAHONING, MEDINA, OTTAWA, PORTAGE, SANDUSKY, STARK, SUMMIT, TRUMBULL & WOOD COUNTIES		
GROUP 1.....	\$ 35.05	13.70
GROUP 2.....	\$ 35.22	13.70
GROUP 3.....	\$ 35.55	13.70
GROUP 4.....	\$ 36.00	13.70
CUYAHOGA AND GEAUGA COUNTIES ONLY: SEWAGE PLANTS, WASTE PLANTS, WATER TREATMENT FACILITIES, PUMPING STATIONS, & ETHANOL PLANTS CONSTRUCTION.....		
	\$ 37.66	13.70
CUYAHOGA, GEAUGA & LAKE COUNTIES		
GROUP 1.....	\$ 36.28	13.70
GROUP 2.....	\$ 36.45	13.70
GROUP 3.....	\$ 36.78	13.70
GROUP 4.....	\$ 37.23	13.70
REMAINING COUNTIES OF OHIO		
GROUP 1.....	\$ 34.62	13.70
GROUP 2.....	\$ 34.79	13.70
GROUP 3.....	\$ 35.12	13.70
GROUP 4.....	\$ 35.57	13.70

LABORER CLASSIFICATIONS

GROUP 1 – Asphalt Laborer; Carpenter Tender; Concrete Curing Applicator; Dump Man (Batch Truck); Guardrail and Fence Installer; Joint Setter; Laborer (Construction); Landscape Laborer; Mesh Handlers & Placer; Right-of-way Laborer; Riprap Laborer & Grouter; Scaffold Erector; Seal Coating; Surface Treatment or Road Mix Laborer; Sign Installer; Slurry Seal; Utility Man; Bridge Man; Handyman; Waterproofing Laborer; Flagperson; Hazardous Waste (level D); Diver Tender; Zone Person & Traffic Control

GROUP 2 – Asphalt Raker; Concrete Puddler; Kettle Man Pipeline); Machine Driven Tools (Gas, Electric, Air); Mason Tender; Brick Paver; Mortar Mixer; Power Buggy or Power Wheelbarrow; Paint Striper; Sheeting & Shoring Man; Surface Grinder Man; Plastic Fusing Machine Operator; Pug Mill Operator; & Vacuum Devices (wet or dry); Rodding Machine Operator; Diver; Screwman or Paver; Screed Person; Water Blast, Hand Held Wand; Pumps 4" & Under (Gas, Air or Electric) & Hazardous Waste (level C); Air Track and Wagon Drill; Bottom Person; Cofferdam (below 25 ft. deep); Concrete Saw Person; Cutting with Burning Torch; Form Setter; Hand Spiker (Railroad); Pipelayer; Tunnel Laborer (without air) & Caisson; Underground Person (working in Sewer and Waterline, Cleaning, Repairing & Reconditioning); Sandblaster Nozzle Person; & Hazardous Waste (level B)

GROUP 3 – Blaster; Mucker; Powder Person; Top Lander; Wrencher (Mechanical Joints & Utility Pipeline); Yarnier; Hazardous Waste (level A); Concrete Specialist; Concrete Crew in Tunnels (With Air-pressurized – \$1.00 premium); Curb Setter & Cutter; Grade Checker; Utility Pipeline Tapper; Waterline; and Caulker

GROUP 4 – Miner (With Air-pressurized – \$1.00 premium); & Gunite Nozzle Person

TUNNEL LABORER WITH AIR-PRESSURIZED ADD \$1.00 TO BASE RATE

SIGNAL PERSON WILL RECEIVE THE RATE EQUAL TO THE RATE PAID THE LABORER CLASSIFICATION FOR WHICH HE OR SHE IS SIGNALING.

PAIN0006-002 05/01/2023

ASHTABULA, CUYAHOGA, GEAUGA, LAKE, LORAIN, PORTAGE (N. of the East-West Turnpike) & SUMMIT (N. of the East-West Turnpike)

	Rates	Fringes
PAINTER		
COMMERCIAL NEW WORK; REMODELING; & RENOVATIONS		
GROUP 1.....	\$ 30.75	18.95
GROUP 2.....	\$ 31.15	18.95
GROUP 3.....	\$ 31.45	18.95
GROUP 4.....	\$ 37.01	18.95
COMMERCIAL REPAINT		
GROUP 1.....	\$ 29.25	18.95
GROUP 2.....	\$ 29.65	18.95
GROUP 3.....	\$ 29.95	18.95

PAINTER CLASSIFICATIONS – COMMERCIAL NEW WORK; REMODELING; & RENOVATIONS

GROUP 1 – Brush; & Roller

GROUP 2 – Sandblasting & Buffing

GROUP 3 – Spray Painting; Closed Steel Above 55 feet; Bridges & Open Structural Steel; Tanks – Water Towers; Bridge Painters; Bridge Riggers; Containment Builders

GROUP 4 – Bridge Blaster

PAINTER CLASSIFICATIONS – COMMERCIAL REPAINT

GROUP 1 – Brush; & Roller

GROUP 2 – Sandblasting & Buffing

GROUP 3 – Spray Painting

PAIN0007-002 07/01/2021

FULTON, HENRY, LUCAS, OTTAWA (Excluding Allen, Bay, Bono, Catawba Island, Clay Center, Curtice, Danbury, Eagle Beach, Elliston, Elmore, Erie, Fishback, Gem Beach & Genova) & WOOD

	Rates	Fringes
PAINTER		
NEW COMMERCIAL WORK		
GROUP 1.....	\$ 28.74	18.77
GROUP 2.....	\$ 28.74	18.77
GROUP 3.....	\$ 28.74	18.77
GROUP 4.....	\$ 28.74	18.77
GROUP 5.....	\$ 28.74	18.77

GROUP 6.....	\$ 28.74	18.77
GROUP 7.....	\$ 28.74	18.77
GROUP 8.....	\$ 28.74	18.77
GROUP 9.....	\$ 28.74	18.77

REPAINT IS 90% OF JR

PAINTER CLASSIFICATIONS

GROUP 1 – Brush; Spray & Sandblasting Pot Tender

GROUP 2 – Refineries & Refinery Tanks; Surfaces 30 ft. or over where material is applied to or labor performed on above ground level (exterior), floor level (interior)

GROUP 3 – Swing Stage & Chair

GROUP 4 – Lead Abatement

GROUP 5 – All Methods of Spray

GROUP 6 – Solvent-Based Catalized Epoxy Materials of 2 or More Component Materials, to include Solvent-Based Conversion Varnish (excluding water based)

GROUP 7 – Spray Solvent Based Material; Sand & Abrasive Blasting

GROUP 8 – Towers; Tanks; Bridges; Stacks Over 30 Feet

GROUP 9 – Epoxy Spray (excluding water based)

PAIN0012-008 05/01/2019

BUTLER COUNTY

	Rates	Fringes
PAINTER		
GROUP 1.....	\$ 21.95	10.20
GROUP 2.....	\$ 25.30	10.20
GROUP 3.....	\$ 25.80	10.20
GROUP 4.....	\$ 26.05	10.20
GROUP 5.....	\$ 26.30	10.20

PAINTER CLASSIFICATIONS

GROUP 1: Bridge Equipment Tender; Bridge/Containment Builder

GROUP 2: Brush & Roller

GROUP 3: Spray

GROUP 4: Sandblasting; & Waterblasting

GROUP 5: Elevated Tanks; Steeplejack Work; Bridge; & Lead Abatement

PAIN0012-010 05/01/2019

BROWN, CLERMONT, CLINTON, HAMILTON & WARREN

Rates Fringes

PAINTER

HEAVY & HIGHWAY BRIDGES-
 GUARDRAILS-LIGHTPOLES-
 STRIPING

Bridge Equipment Tender and Containment Builder....\$ 21.95	10.20
Bridges when highest point of clearance is 60 feet or more; & Lead Abatement Projects.....\$ 26.30	10.20
Brush & Roller.....\$ 25.30	10.20
Sandblasting & Hopper Tender; Water Blasting.....\$ 26.05	10.20
Spray.....\$ 25.80	10.20

PAIN0093-001 12/01/2022

ATHENS, GUERNSEY, HOCKING, MONROE, MORGAN, NOBLE and
 WASHINGTON COUNTIES

Rates Fringes

PAINTER

Bridges; Locks; Dams; Tension Towers; & Energized Substations.....\$ 34.81	22.47
Power Generating Facilities.\$ 31.66	22.47

PAIN0249-002 05/01/2023

CLARK, DARKE, GREENE, MIAMI, MONTGOMERY & PREBLE

Rates Fringes

PAINTER

GROUP 1 - Brush & Roller....\$ 26.23	12.56
GROUP 2 - Swing, Scaffold Bridges; Structural Steel; Open Acid Tank; High Tension Electrical Equipment; & Hot Pipes.....\$ 26.23	12.56
GROUP 3 - Spray; Sandblast; Steamclean; Lead Abatement.....\$ 26.98	12.56
GROUP 4 - Steeplejack Work..\$ 27.18	12.56
GROUP 5 - Coal Tar.....\$ 27.73	12.56
GROUP 6 - Bridge Equipment Tender & or Containment Builder.....\$ 34.94	12.56
GROUP 7 - Tanks, Stacks & Towers.....\$ 29.87	12.56
GROUP 8 - Bridge Blaster, Rigger.....\$ 37.94	12.56

PAIN0356-002 09/01/2009

KNOX, LICKING, MUSKINGUM, and PERRY

Rates Fringes

PAINTER

Bridge Equipment Tenders

and Containment Builders....\$ 27.93	7.25
Bridges; Blasters; and Riggers.....\$ 34.60	7.25
Brush and Roller.....\$ 20.93	7.25
Sandblasting; Steam Cleaning; Waterblasting; and Hazardous Work.....\$ 25.82	7.25
Spray.....\$ 21.40	7.25
Structural Steel and Swing Stage.....\$ 25.42	7.25
Tanks; Stacks; and Towers...\$ 28.63	7.25

PAIN0438-002 12/01/2021

BELMONT, HARRISON and JEFFERSON COUNTIES

Rates Fringes

PAINTER

Bridges, Locks, Dams, Tension Towers & Energized Substations.....\$ 34.44	18.19
Power Generating Facilities.\$ 32.29	18.19

PAIN0476-001 06/01/2023

COLUMBIANA, MAHONING, and TRUMBULL COUNTIES

Rates Fringes

PAINTER

GROUP 1.....\$ 27.49	17.06
GROUP 2.....\$ 34.12	17.06
GROUP 3.....\$ 27.70	17.06
GROUP 4.....\$ 27.99	17.06
GROUP 5.....\$ 28.14	17.06
GROUP 6.....\$ 28.39	17.06
GROUP 7.....\$ 29.49	17.06

PAINTER CLASSIFICATIONS:

GROUP 1: Painters, Brush & Roller

GROUP 2: Bridges

GROUP 3: Structural Steel

GROUP 4: Spray, Except Bar Joist/Deck

GROUP 5: Epoxy/Mastic; Spray- Bar Joist/Deck; Working Above
50 Feet; and Swingstages

GROUP 6: Tanks; Sandblasting

GROUP 7: Towers; Stacks

PAIN0555-002 06/01/2021

ADAMS, HIGHLAND, JACKSON, PIKE & SCIOTO

Rates Fringes

PAINTER

GROUP 1.....\$ 31.95	17.05
----------------------	-------

GROUP 2.....	\$ 33.47	17.05
GROUP 3.....	\$ 34.99	17.05
GROUP 4.....	\$ 37.97	17.05

PAINTER CLASSIFICATIONS

GROUP 1 – Containment Builder

GROUP 2 – Brush; Roller; Power Tools, Under 40 feet

GROUP 3 – Sand Blasting; Spray; Steam Cleaning; Pressure Washing; Epoxy & Two Component Materials; Lead Abatement; Hazardous Waste; Toxic Materials; Bulk & Storage Tanks of 25,000 Gallon Capacity or More; Elevated Tanks

GROUP 4 – Stacks; Bridges

PAIN0639-001 05/01/2011

	Rates	Fringes
Sign Painter & Erector.....	\$ 20.61	3.50+a+b+c

FOOTNOTES: a. 7 Paid Holidays: New Year's Day; Memorial Day; July 4th; Labor Day; Thanksgiving Day; Christmas Day & 1 Floating Day
 b. Vacation Pay: After 1 year's service – 5 days' paid vacation; After 2, but less than 10 years' service – 10 days' paid vacation; After 10, but less than 20 years' service – 15 days' paid vacation; After 20 years' service – 20 days' paid vacation
 c. Funeral leave up to 3 days maximum paid leave for death of mother, father, brother, sister, spouse, child, mother-in-law, father-in-law, grandparent and inlaw provided employee attends funeral

PAIN0788-002 06/01/2022

ASHLAND, CRAWFORD, ERIE, HANCOCK, HURON, MARION, MORROW, OTTAWA (Allen, Bay, Bono, Catawba Island, Clay Center, Curtice, Danbury, Eagle Beach, Elliston, Elmore, Erie, Fishback, Gem Beach & Genoa), RICHLAND, SANDUSKY, SENECA & WYANDOT

	Rates	Fringes
PAINTER		
Brush & Roller.....	\$ 25.08	16.72
Structural Steel.....	\$ 26.68	16.72

WINTER REPAINT: Between December 1 to March 31 – 90%JR

\$.50 PER HOUR SHALL BE ADDED TO THE RATE OF PAY FOR THE CLASSIFICATION OF WORK:

While working swingstage, boatswain chair, needle beam and horizontal cable. While operating sprayguns, sandblasting, cobblasting and high pressure waterblasting (4000psi).

\$1.00 PER HOUR SHALL BE ADDED TO THE RATE OF PAY FOR THE CLASSIFICATION OF WORK:

For the application of catalized epoxy, including latex epoxy

that is deemed hazardous, lead abatement, or for work or material where special precautions beyond normal work duties must be taken. For working on stacks, tanks, and towers over 40 feet in height.

PAIN0813-005 12/01/2008

GALLIA, LAWRENCE, MEIGS & VINTON

	Rates	Fringes
PAINTER		
Base Rate.....	\$ 24.83	10.00
Bridges, Locks, Dams & Tension Towers.....	\$ 27.83	10.00

* PAIN0841-001 06/01/2023

MEDINA, PORTAGE (South of and including Ohio Turnpike), and
SUMMIT (South of and including Ohio Turnpike) COUNTIES

	Rates	Fringes
Painters:		
GROUP 1.....	\$ 30.18	15.50
GROUP 2.....	\$ 30.83	15.50
GROUP 3.....	\$ 30.93	15.50
GROUP 4.....	\$ 31.03	15.50
GROUP 5.....	\$ 31.43	15.50
GROUP 6.....	\$ 39.20	11.75
GROUP 7.....	\$ 31.68	15.50

PAINTER CLASSIFICATIONS:

GROUP 1 – Brush, Roller & Paperhanger

GROUP 2 – Epoxy Application

GROUP 3 – Swing Scaffold, Bosum Chair, & Window Jack

GROUP 4 – Spray Gun Operator of Any & All Coatings

GROUP 5 – Sandblast, Painting of Standpipes, etc. from
Scaffolds, Bridge Work and/or Open Structural Steel,
Standpipes and/or Water Towers

GROUP 6 – Public & Commerce Transportation, Steel or
Galvanized, Bridges, Tunnels & Related Support Items
(concrete)

GROUP 7 – Synthetic Exterior, Drywall Finisher and/or Taper,
Drywall Finisher and Follow-up Man Using Automatic Tools

PAIN0841-002 06/01/2022

CARROLL, COSHOCTON, HOLMES, STARK, TUSCARAWAS & WAYNE

	Rates	Fringes
PAINTER		
Bridges; Towers, Poles & Stacks; Sandblasting		

Steel; Structural Steel & Metalizing.....	\$ 23.50	15.45
Brush & Roller.....	\$ 28.18	15.45
Spray; Tank Interior & Exterior.....	\$ 23.50	15.45

PAIN1020-002 07/01/2023

ALLEN, AUGLAIZE, CHAMPAIGN, DEFIANCE, HARDIN, LOGAN, MERCER, PAULDING, PUTNAM, SHELBY, VAN WERT, and WILLIAMS COUNTIES

	Rates	Fringes
PAINTER		
Brush & Roller.....	\$ 26.64	15.56
Drywall Finishing & Taping..	\$ 27.39	15.56
Lead Abatement.....	\$ 28.39	15.56
Spray, Sandblasting Pressure Cleaning, & Refinery.....	\$ 27.39	15.56
Swing Stage, Chair, Spiders, & Cherry Pickers...	\$ 26.89	15.56
Wallcoverings.....	\$ 27.39	15.56

All surfaces 40 ft. or over where material is applied to or labor performed on, above ground level (exterior), floor level (interior) - \$.50 premium

Applying Coal Tar Products - \$1.00 premium

PAIN1275-002 05/01/2023

DELAWARE, FAIRFIELD, FAYETTE, FRANKLIN, MADISON, PICKAWAY, ROSS & UNION

	Rates	Fringes
PAINTER		
Bridges.....	\$ 35.57	14.25
Brush; Roller.....	\$ 29.96	14.25
Sandblasting; Steamcleaning; Waterblasting (3500 PSI or Over)& Hazardous Work.....	\$ 30.66	14.25
Spray.....	\$ 30.46	14.25
Stacks; Tanks; & Towers.....	\$ 32.77	14.25
Structural Steel & Swing Stage.....	\$ 28.81	14.25

PLAS0109-001 05/01/2018

MEDINA, PORTAGE, STARK, and SUMMIT COUNTIES

	Rates	Fringes
PLASTERER.....	\$ 28.86	17.11

PLAS0109-003 05/01/2018

CARROLL, HOLMES, TUSCARAWAS, and WAYNE COUNTIES

Rates	Fringes
-------	---------

PLASTERER.....\$ 28.21 17.11

PLAS0132-002 07/01/2023

BROWN, BUTLER, CLERMONT, HAMILTON, HIGHLAND, WARREN COUNTIES

Rates Fringes

PLASTERER.....\$ 28.40 16.24

PLAS0404-002 05/01/2018

ASHTABULA, CUYAHOGA, GEAUGA, AND LAKE COUNTIES

Rates Fringes

PLASTERER.....\$ 29.63 17.11

PLAS0404-003 05/01/2018

LORAIN COUNTY

Rates Fringes

PLASTERER.....\$ 28.86 17.11

PLAS0526-022 05/01/2018

COLUMBIANA, MAHONING, and TRUMBULL COUNTIES

Rates Fringes

PLASTERER.....\$ 28.86 17.11

PLAS0526-023 05/01/2018

BELMONT, HARRISON, and JEFFERSON COUNTIES

Rates Fringes

PLASTERER.....\$ 28.21 17.11

PLAS0886-001 05/01/2018

FULTON, HANCOCK, HENRY, LUCAS, PUTNAM, and WOOD COUNTIES

Rates Fringes

PLASTERER.....\$ 29.63 17.11

PLAS0886-003 05/01/2018

DEFIANCE, ERIE, HURON, OTTAWA, PAULDING, SANDUSKY, and SENECA COUNTIES

Rates Fringes

PLASTERER.....\$ 28.86 17.11

PLAS0886-004 05/01/2018

ALLEN, AUGLAIZE, HARDIN, LOGAN, MERCER, and VAN WERT COUNTIES

	Rates	Fringes
PLASTERER.....	\$ 28.21	17.11

PLUM0042-002 07/01/2023

ASHLAND, CRAWFORD, ERIE, HURON, KNOX, LORAIN, MORROW, RICHLAND & WYANDOT

	Rates	Fringes
Plumber, Pipefitter, Steamfitter.....	\$ 37.62	25.47

PLUM0050-002 07/04/2022

DEFIANCE, FULTON, HANCOCK, HENRY, LUCAS, OTTAWA, PAULDING, PUTNAM, SANDUSKY, SENECA, WILLIAMS & WOOD

	Rates	Fringes
Plumber, Pipefitter, Steamfitter.....	\$ 44.60	28.51

PLUM0055-003 05/01/2022

ASHTABULA, CUYAHOGA, GEAUGA, LAKE, MEDINA (N. of Rte. #18 & Smith Road) & SUMMIT (N. of Rte. #303, including the corporate limits of the city of Hudson)

	Rates	Fringes
PLUMBER.....	\$ 40.00	28.43

PLUM0083-001 07/01/2017

BELMONT & MONROE (North of Rte. #78)

	Rates	Fringes
Plumber and Steamfitter.....	\$ 32.16	31.51

PLUM0094-002 05/01/2023

CARROLL (Northen Half), STARK, and WAYNE COUNTIES

	Rates	Fringes
PLUMBER/PIPEFITTER.....	\$ 38.03	23.09

PLUM0120-002 05/01/2023

ASHTABULA, CUYAHOGA, GEAUGA, LAKE, LORAIN (the C.E.I. Power House in Avon Lake), MEDINA (N. of Rte. #18) & SUMMIT (N. of #303)

	Rates	Fringes
PIPEFITTER.....	\$ 45.62	27.30

PLUM0162-002 06/01/2022

CHAMPAIGN, CLARK, CLINTON, DARKE, FAYETTE, GREENE, MIAMI, MONTGOMERY & PREBLE

	Rates	Fringes
Plumber, Pipefitter, Steamfitter.....	\$ 36.47	26.80

PLUM0168-002 06/01/2023

MEIGS, MONROE (South of Rte. #78), MORGAN (South of Rte. #78) & WASHINGTON

	Rates	Fringes
PLUMBER/PIPEFITTER.....	\$ 38.95	34.97

PLUM0189-002 06/01/2022

DELAWARE, FAIRFIELD, FRANKLIN, HOCKING, LICKING, MADISON, MARION, PERRY, PICKAWAY, ROSS & UNION

	Rates	Fringes
Plumber, Pipefitter, Steamfitter.....	\$ 43.25	26.94

PLUM0219-002 06/01/2022

MEDINA (Rte. #18 from eastern edge of Medina Co., west to eastern corporate limits of the city of Medina, & on the county road from the west corporate limits of Medina running due west to and through community of Risley to the western edge of Medina County - All territory south of this line), PORTAGE, and SUMMIT (S. of Rte. #303) COUNTIES

	Rates	Fringes
Plumber and Steamfitter.....	\$ 41.22	26.64

PLUM0392-002 06/01/2023

BROWN, BUTLER, CLERMONT, HAMILTON & WARREN

	Rates	Fringes
PLUMBER/PIPEFITTER.....	\$ 38.62	25.83

PLUM0396-001 06/01/2023

COLUMBIANA (Excluding Washington & Yellow Creek Townships & Liverpool Twp. - Secs. 35 & 36 - West of County Road #427), MAHONING and TRUMBULL COUNTIES

	Rates	Fringes
PLUMBER/PIPEFITTER.....	\$ 37.10	28.51

PLUM0495-002 06/01/2023

CARROLL (Rose, Monroe, Union, Lee, Orange, Perry & Loudon Townships), COLUMBIANA (Washington & Yellow Creek Townships & Liverpool Township, Secs. 35 & 36, West of County Rd. #427), COSHOCTON, GUERNSEY, HARRISON, HOLMES, JEFFERSON, MORGAN (South to State Rte. #78 & from McConnelville west on State Rte. #37 to the Perry County line), MUSKINGUM, NOBLE, and TUSCARAWAS COUNTIES

	Rates	Fringes
Plumber, Pipefitter, Steamfitter.....	\$ 36.82	35.40

PLUM0577-002 06/01/2023

ADAMS, ATHENS, GALLIA, HIGHLAND, JACKSON, LAWRENCE, PIKE, SCIOTO & VINTON

	Rates	Fringes
Plumber, Pipefitter, Steamfitter.....	\$ 39.98	26.48

PLUM0776-002 07/01/2023

ALLEN, AUGLAIZE, HARDIN, LOGAN, MERCER, SHELBY and VAN WERT COUNTIES

	Rates	Fringes
Plumber, Pipefitter, Steamfitter.....	\$ 40.07	28.95

TEAM0377-003 05/01/2023

STATEWIDE, EXCEPT CUYAHOGA, GEAUGA & LAKE

	Rates	Fringes
TRUCK DRIVER		
GROUP 1.....	\$ 31.49	16.40
GROUP 2.....	\$ 31.91	16.40

TRUCK DRIVER CLASSIFICATIONS

GROUP 1 - Asphalt Distributor; Batch; 4- Wheel Service; 4-Wheel Dump; Oil Distributor & Tandem

GROUP 2 - Tractor-Trailer Combination: Fuel; Pole Trailer; Ready Mix; Semi-Tractor; & Asphalt Oil Spraybar Man When Operated From Cab; 5 Axles & Over; Belly Dump; End Dump; Articulated Dump; Heavy Duty Equipment; Low Boy; & Truck Mechanic

TEAM0436-002 05/01/2023

CUYAHOGA, GEAUGA & LAKE

Rates Fringes

TRUCK DRIVER

GROUP 1.....	\$ 31.00	18.95
GROUP 2.....	\$ 32.50	18.95

GROUP 1: Straight & Dump, Straight Fuel

GROUP 2: Semi Fuel, Semi Tractor, Euclids, Darts, Tank, Asphalt Spreaders, Low Boys, Carry-All, Tourna-Rockers, Hi-Lifts, Extra Long Trailers, Semi-Pole Trailers, Double Hook-Up Tractor Trailers including Team Track & Railroad Siding, Semi-Tractor & Tri-Axle Trailer, Tandem Tractor & Tandem Trailer, Tag Along Trailer, Expandable Trailer or Towing Requiring Road Permits, Ready-Mix (Agitator or Non-Agitator), Bulk Concrete Driver, Dry Batch Truck, Articulated End Dump

WELDERS - Receive rate prescribed for craft performing operation to which welding is incidental.

=====

** Workers in this classification may be entitled to a higher minimum wage under Executive Order 14026 (\$16.20) or 13658 (\$12.15). Please see the Note at the top of the wage determination for more information.

Note: Executive Order (EO) 13706, Establishing Paid Sick Leave for Federal Contractors applies to all contracts subject to the Davis-Bacon Act for which the contract is awarded (and any solicitation was issued) on or after January 1, 2017. If this contract is covered by the EO, the contractor must provide employees with 1 hour of paid sick leave for every 30 hours they work, up to 56 hours of paid sick leave each year. Employees must be permitted to use paid sick leave for their own illness, injury or other health-related needs, including preventive care; to assist a family member (or person who is like family to the employee) who is ill, injured, or has other health-related needs, including preventive care; or for reasons resulting from, or to assist a family member (or person who is like family to the employee) who is a victim of, domestic violence, sexual assault, or stalking. Additional information on contractor requirements and worker protections under the EO is available at <https://www.dol.gov/agencies/whd/government-contracts>.

Unlisted classifications needed for work not included within the scope of the classifications listed may be added after award only as provided in the labor standards contract clauses (29CFR 5.5 (a) (1) (ii)).

The body of each wage determination lists the classification and wage rates that have been found to be prevailing for the cited type(s) of construction in the area covered by the wage determination. The classifications are listed in alphabetical order of ""identifiers"" that indicate whether the particular rate is a union rate (current union negotiated rate for local), a survey rate (weighted average rate) or a union average rate (weighted union average rate).

Union Rate Identifiers

A four letter classification abbreviation identifier enclosed in dotted lines beginning with characters other than ""SU"" or ""UAVG"" denotes that the union classification and rate were prevailing for that classification in the survey. Example: PLUM0198-005 07/01/2014. PLUM is an abbreviation identifier of the union which prevailed in the survey for this classification, which in this example would be Plumbers. 0198 indicates the local union number or district council number where applicable, i.e., Plumbers Local 0198. The next number, 005 in the example, is an internal number used in processing the wage determination. 07/01/2014 is the effective date of the most current negotiated rate, which in this example is July 1, 2014.

Union prevailing wage rates are updated to reflect all rate changes in the collective bargaining agreement (CBA) governing this classification and rate.

Survey Rate Identifiers

Classifications listed under the ""SU"" identifier indicate that no one rate prevailed for this classification in the survey and the published rate is derived by computing a weighted average rate based on all the rates reported in the survey for that classification. As this weighted average rate includes all rates reported in the survey, it may include both union and non-union rates. Example: SULA2012-007 5/13/2014. SU indicates the rates are survey rates based on a weighted average calculation of rates and are not majority rates. LA indicates the State of Louisiana. 2012 is the year of survey on which these classifications and rates are based. The next number, 007 in the example, is an internal number used in producing the wage determination. 5/13/2014 indicates the survey completion date for the classifications and rates under that identifier.

Survey wage rates are not updated and remain in effect until a new survey is conducted.

Union Average Rate Identifiers

Classification(s) listed under the UAVG identifier indicate that no single majority rate prevailed for those classifications; however, 100% of the data reported for the classifications was union data. EXAMPLE: UAVG-OH-0010 08/29/2014. UAVG indicates that the rate is a weighted union average rate. OH indicates the state. The next number, 0010 in the example, is an internal number used in producing the wage determination. 08/29/2014 indicates the survey completion date for the classifications and rates under that identifier.

A UAVG rate will be updated once a year, usually in January of each year, to reflect a weighted average of the current negotiated/CBA rate of the union locals from which the rate is based.

WAGE DETERMINATION APPEALS PROCESS

1.) Has there been an initial decision in the matter? This can be:

- * an existing published wage determination
- * a survey underlying a wage determination
- * a Wage and Hour Division letter setting forth a position on a wage determination matter
- * a conformance (additional classification and rate) ruling

On survey related matters, initial contact, including requests for summaries of surveys, should be with the Wage and Hour National Office because National Office has responsibility for the Davis-Bacon survey program. If the response from this initial contact is not satisfactory, then the process described in 2.) and 3.) should be followed.

With regard to any other matter not yet ripe for the formal process described here, initial contact should be with the Branch of Construction Wage Determinations. Write to:

Branch of Construction Wage Determinations
 Wage and Hour Division
 U.S. Department of Labor
 200 Constitution Avenue, N.W.
 Washington, DC 20210

2.) If the answer to the question in 1.) is yes, then an interested party (those affected by the action) can request review and reconsideration from the Wage and Hour Administrator (See 29 CFR Part 1.8 and 29 CFR Part 7). Write to:

Wage and Hour Administrator
 U.S. Department of Labor
 200 Constitution Avenue, N.W.
 Washington, DC 20210

The request should be accompanied by a full statement of the interested party's position and by any information (wage payment data, project description, area practice material, etc.) that the requestor considers relevant to the issue.

3.) If the decision of the Administrator is not favorable, an interested party may appeal directly to the Administrative Review Board (formerly the Wage Appeals Board). Write to:

Administrative Review Board
 U.S. Department of Labor
 200 Constitution Avenue, N.W.
 Washington, DC 20210

4.) All decisions by the Administrative Review Board are final.

=====

END OF GENERAL DECISIO"

SECTION VII

Sample Contract and Change Order Form

WAR-TR55-2.11

CONTRACT 2023-05

PROJECT NO. 2023-05 WAR-TR55-2.11

THIS AGREEMENT, made and entered into this 27th day of October, 2023, by and between the Warren County Transportation Improvement District, 210 West Main Street, Lebanon, OH 45036, hereafter designated as the WCTID, and Sunesis Construction Company, hereinafter designated as the Contractor.

WITNESSETH: That the Contractor has agreed, and by these presents does agree with the WCTID for the consideration herein below mentioned, to furnish at Contractor's own proper cost and expense all necessary materials and labor of every description, and to carry out complete in good, firm and timely substantial manner the following project in accordance with the surveys, plats, plans, cross-sections and profiles and specifications on file in the office of the said WCTID and in accordance with the specifications and conditions hereinbefore and hereinafter set forth, all of which are made a part hereof as if totally rewritten herein:

PROJECT NO. 2023-05, WAR-TR55-2.11 (aka Irwin-Simpson Shared Use Path)

The project includes the furnishing of all labor, equipment, and materials needed to construct Project No. 2023-05: WAR-TR55-2.11 (aka Irwin-Simpson Shared Use Path).

The provisions contained in the "Notice to Contractors," the "General Instructions," the "Bid Proposal," and the "General Provisions" (including any conditions or specifications incorporated therein), as well as any provisions in the surveys, plats, cross-sections, profiles, and other associated plans for this work on file in the offices of the WCTID, are also hereby combined, and incorporated by reference thereto, as part of this agreement.

The Contractor shall pay into the State Insurance Fund the amount of premium determined and fixed by the Industrial Commission of Ohio, promptly when due, or elect to pay compensation direct and contribute to the surplus of the fund as provided by law. The Contractor and his Surety agree to defend and indemnify WCTID, WCEO, Warren County and the Township against liability and loss by reason of the breach of the obligation of this paragraph and agree that it shall run to the benefit of the Industrial Commission of Ohio and the State Insurance Fund for the recovery of premiums that should have been paid. All of the foregoing provisions of this paragraph shall be equally binding upon each sub-contractor whose performance thereof is warranted by the Contractor who employs such sub-contractor. The Warren County Transportation Improvement District may require of the Contractor, as a condition of permitting the beginning or continuance of work, a Certificate of Compliance with the paragraph issued by the Industrial Commission of Ohio.

In consideration whereof, the WCTID hereby agrees and promises to pay to the Contractor, at the times, under the conditions and in the manner provided in the specifications, and in full of all compensation for material furnished or work done thereunder, at the unit prices, or lump sum, as stated in the proposal, the sum of approximately:

TOTAL AMOUNT: \$ _____ (the "Contract Price")

The date of completion of the entire Work under this Contract shall be December 31st, 2024 (the "Date of Completion").

The delivery of a signed copy of this Agreement by Facsimile Transmission (fax) or by e-mail transmission in Portable Digital Format (pdf) shall constitute effective execution and delivery of this contract as to the parties; and will create a valid and binding obligation of the party executing (or on whose behalf such signature is executed) with the same force and effect as if such fax or pdf signature page were an original agreement. Signatures of the parties to this contract

transmitted by facsimile or PDF will be deemed to be their original signatures for all purposes. This Agreement may be executed in one or more counterparts, each of which shall be deemed an original and all of which together shall constitute one and the same instrument. It shall not be necessary in proving this Agreement to produce or account for more than one of those counterparts.

CONTRACTOR

**WARREN COUNTY TRANSPORTATION IMPROVEMENT DISTRICT,
WARREN COUNTY, OHIO**

(COMPANY/CORPORATION NAME)

(Chair)

(SIGNATURE OF OWNER/AGENT)

(TITLE/POSITION)

APPROVED AS TO FORM:

WCTID Legal Counsel

Date

Warren County Transportation Improvement District (WCTID)

PROJECT: WAR-TR55-2.11 (PID 114603)

Contract No.: 2023-05

CONTRACTOR: _____

Change Order No: _____

The terms and conditions of the above-referenced Contract shall govern this Change Order. This Change Order is mutually agreed to amend the above-referenced Contract as follows:

The Contract Sum will be adjusted as follows, and any payments made to Contractor hereunder will be paid according to the terms of the Contract. The change, if any, in the Contract Price shall be computed according to one of the following methods (select as appropriate):

- 1. No Change
- 2. Lump Sum of \$ _____
- 3. Unit Price GMP _____
- 4. Other (Describe) _____

The Contract Time will be increased by _____ () calendar Days. If left blank, this shall be considered a zero time extension Change Order.

By signing below, Contractor acknowledges that this Change Order is a full and final settlement of all claims against Warren County, the Warren County Transportation Improvement District, the Engineer, and their respective officers, trustees, partners, members, agents, and volunteers arising from the work described in this Change Order and any other work affected by or related to the work described herein (collectively the "Change Order Work"). Thus as consideration for this Change Order, Contractor hereby releases all claims for any additional compensation or time extensions arising out of or related to the Change Order Work, including but not limited to, claims for additional compensation for any materials, labor, services, overhead, profit, and any time extensions or damages arising out of or related to any delays or impacts on the Contractor's schedule for performance of the Contract and Change Order Work ("Claims"). Contractor expressly waives any right to pursue any further Claims arising out of or related to the Change Order Work. Any Contractor Claims back-up, change order proposals, change orders or other documentation that may be attached to this Change Order are agreed solely to described the changed work in question and, if applicable, the Contractor's pricing thereof, but does not vary, amend, alter in any way, the terms and conditions herein and the scope of the terms, conditions, agreements, payment amounts, releases, and waivers expressly set forth in this Change Order. Any estimated quantities of items of Unit Price Work are not guaranteed and are solely to determine an initial guaranteed maximum change order price. Engineer will determine the actual quantities and classifications of Unit Price Work that Contractor performs but in no event shall the final change in Contract Price exceed the amount(s) set forth above.

Recommended By: _____ Date: _____
Warren County Engineer's Office
Printed Name: _____

Accepted By: _____ Date: _____
Contractor
Printed Name: _____

Accepted By: _____ Date: _____
Secretary-Treasurer – Warren County TID
Printed Name: _____

SECTION IX

Utility Notes

4A

Warren – TR 55 – Section 2.11

“Bidders are advised that the following utilities facilities will not be cleared from the construction area at the time of award of the contract. These utility facilities shall remain in place or be relocated within the construction limits of the project asset our below.”

All station locations listed below are approximate unless otherwise stated.

Warren County Water and Sewer

Warren County Water and Sewer has an existing sanitary main along the right side of the Irwin Simson Road Centerline from stations 17+15 to 24+25. The offset from the centerline of Irwin Simpson Road varies from 35' to 72'. The main turns north and exits the construction limits at station 24+22.81. The main sits approximately 11 feet deep and will not be disturbed. The Contractor will adjust two manholes located at stations 20+90.56 and 24+22.81 to grade.

General Comments

The contractor shall exercise caution when working in proximity to the existing and/or relocated utility facilities.

Sections 105.07 and 107.16 of the department of transportation construction and materials specifications require, among other things that the contractor cooperate with all utilities located within the limits of this construction project and take responsibility for the protection of the utility property and services.

LEGAL NOTICE TO CONTRACTORS

The Warren County Transportation Improvement District (WCTID), in cooperation and coordination with the Warren County Engineer's Office, will be accepting sealed bids for the furnishing of all labor, equipment, and materials needed to construct ODOT PID **114603 : WAR-TR55-2.11** (aka Irwin-Simpson Road Shared Use Path) in accordance with the applicable Ohio Department of Transportation Construction and Material Specifications (effective January 1, 2023 and its revisions and supplements), Standard Construction Drawings, Standard Bridge Drawings, Ohio Manual of Uniform Traffic Control, The State of Ohio Department of Transportation Bridge Design Manual, and other applicable standards in force on the date of letting and in accordance with the Project Specifications and Construction Plans on file in the office of the Warren County Engineer.

This project is Construct shared use trail along Irwin Simpson from Mason Montgomery Road to the existing trail just west of Duke Boulevard in Deerfield Township, Warren County, Ohio. The Engineer's estimate for this project is Eight Hundred and Fifty Thousand Dollars and no cents (\$850,000.00).

All bids must be submitted in conformance with the requirements of the Project Specifications and in a sealed envelope marked: ODOT PID **114603: WAR-TR55-2.11**, and received in the office of the Warren County Engineer, 210 W Main Street, Lebanon, Ohio 45036, no later than 11:00 a.m. Local Time on Thursday, December 14, 2023, and then at said time bids will be opened and read aloud.

Bid documents and specifications are available after November 13, 2023, on the Warren County website at <http://www.co.warren.oh.us/commissioners/Bids/Default.aspx>. Questions regarding the technical specifications should be directed to Dan Corey, P.E., Warren County Engineer's Office at 513-431-1229 or Dan.Corey@co.warren.oh.us. **Each contractor shall be ODOT prequalified.**

This notice is posted on the Warren County website at: <https://www.co.warren.oh.us/Commissioners/Bids/Default.aspx>. Contact the Warren County Commissioner's Office at (513) 695-1250 should you need assistance in accessing the bidding information on the County's website. **All contract addenda will be posted to the website prior to the bid opening. Bidders should check the website regularly to stay updated on any changes to the project.**

Please be aware that if you are downloading this document to bid this project, and in order to stay updated on any change, please email Krystal Powell in the Commissioners' Office at krystal.powell@co.warren.oh.us with your contact information.

Bidders must comply with the Davis Bacon prevailing wage rates, herein this Bid Package. Bidders must be ODOT Prequalified for the applicable work types at the time of bidding, award, and throughout the life of the construction contract.

WCTID reserves the right to waive any informalities, reject any or all bids and to hold such bids for a period of sixty (60) days before taking any action thereon, and to award a contract to the best, most responsive and responsible Bidder.

WARREN COUNTY TRANSPORTATION IMPROVEMENT DISTRICT
WARREN COUNTY, OHIO